



Arab Republic of Egypt  
Ministry of Education  
& Technical Education  
Central Administration of  
Book Affairs

# Mathematics

For  
First preparatory Grade  
Second term

Author

Gamal Fathy Abdel-sattar

Revised by

Mr/ Samir Mohamed Sedawy

Consultant of  
Mathematics

Mr. / Gamal El shahed

2021 - 2022

غير مصرح بتداول هذا الكتاب خارج وزارة التربية والتعليم والتعليم الفني



## Introduction

It gives us pleasure to introduce this book to our students of the first form preparatory, hoping that it will fulfill our aims; considering the easiness of information, clearness in the style. This for preparing a generation capable of scientific thinking and innovation.

The aspirations of the human mind exceeds the limits of the earth to penetrate the outer space. As the artificial satellites and information networks transfer to us what is happening every where at any time.

The technological progress makes various and a lot of sources for learning, a large number of modes of knowledge and numerous teaching aids that have a great effect and considered more complex and have a higher value.

**In writing this book, it was put into consideration the following points:**

- Since studying integers is not enough to solve various life problems, so we should study mathematics that uses symbols instead of numbers to solve such problems.
- The use of images, shapes and colors in clarifying the concepts of mathematics and properties of shapes.
- Integration and linkages between mathematics and other subjects.
- The design of educational situations, which help on practising the basis of active learning and problem - solving skills.
- Showing lessons that provide the students with the opportunity to deduce the information by themselves.
- The book includes realistic issues, educational activities, attitudes related to the problems of environment, health, population issues in addition to the development of values such as human rights, equality, justice and developing concepts of belonging to the home land.
- Giving a variety of evaluation exercises, at the end of each lesson, a test at the end of each unit and examinations at the end of the book.
- Include portfolio models to verify the general educational evaluation.
- Employing technological methods.

**This book has included three units:**

Unit 1: Numbers and Algebra - it aims to use laws of indices and finding the square root of a positive rational number.

- it presents the meaning of variable and constant and solving equations and inequalities of first degree in one variable.

Unit 2: statistics - it aims to include the importance of statistics and probability in predicting future events.

Unit 3: Geometry and measurement - it revolves around Geometric transformations (reflection - translation - rotation), proving using proof, some theorems and laws for triangles and quadrilaterals.

**In explaining the topics of the book, it was taken into consideration, simplifying the subject and giving a variety of exercises to provide the students with the opportunity to think and create.**

The Author

## List of symbols

There is a meaning for each mathematical symbol

Symbol	How read
$X = \{\dots\dots, \dots\dots, \dots\dots\}$	X is the set whose elements are
$\emptyset$ or $\{ \}$	empty set or null set
$\in$	is an element of, belongs to
$\notin$	is not an element of, not belongs to
$\subset$	is a subset of
$\not\subset$	is not a subset of
$X \cap Y = \{a : a \in X \text{ and } a \in Y\}$	Intersection of two sets X and Y is the set which contains all the elements belonging to X and Y.
$X \cup Y = \{a : a \in X \text{ or } a \in Y\}$	Union of two sets X and Y is that set which contains all the elements belonging to X or Y.
$\mathbb{N}$	Set of Natural numbers $\{0, 1, 2, \dots\}$
$\mathbb{Z}$	Set of integers $\{\dots, -2, -1, 0, 1, 2, \dots\}$
$\mathbb{Z}^+$	Set of positive integers $\{1, 2, 3, \dots\}$
$\mathbb{Z}^-$	Set of negative Integers $\{-1, -2, -3, \dots\}$
$\leq$	is less than or equal to
$\geq$	is greater than or equal to

Symbol	How read
$\neq$	is not equal to
$ a $	The absolute value of a
$(a, b)$	The ordered pair whose first coordinate a and second coordinate b.
$a \times a \times \dots$ to n factors $= a^n$	The $n^{\text{th}}$ power for the number a
$\sqrt{a}$	The square root of a
$//$	is parallel to
$\perp$	is perpendicular to
$\Delta$	triangle
$\because$	Since
$\therefore$	Therefore
	right angle
$\overline{AB}$	Line segment AB
$\overrightarrow{AB}$	Ray AB
$\longleftrightarrow AB$	The straight line AB
$\sphericalangle$	Angle
$\equiv$	is congruent to

## Contents

<b>Unit 1: Numbers and Algebra</b> .....	<b>1</b>
Lesson 1 : Repeated multiplication .....	2
Lesson 2 : Non-negative Integer powers .....	5
Lesson 3 : Negative Integer powers .....	11
Lesson 4 : Scientific Notation .....	13
Lesson 5 : Order of operations .....	15
Lesson 6 : The square root of a rational number .....	17
Lesson 7 : Solving Equations .....	19
Lesson 8 : Inequalities .....	24
● Miscellaneous Exercises .....	28
● Unit test .....	29
<b>Unit 2: Probability and statistics</b> .....	<b>31</b>
Lesson 1 : Samples .....	32
Lesson 2 : Probability .....	35
● Experimental probability .....	35
● Theoretical probability .....	37
Activity .....	41
Unit test .....	45
<b>Unit 3: Geometry and Measurement</b> .....	<b>47</b>
Lesson 1 : Deductive proof .....	48
Lesson 2 : The polygon .....	53
Lesson 3 : The triangle .....	63
Lesson 4 : Pythagoras theorem .....	71
Lesson 5 : Geometric transformations .....	75
Lesson 6 : Reflection .....	79
Lesson 7 : Translation .....	91
Lesson 8 : Rotation .....	98
Activity .....	104
Unit test .....	106
<b>Model exams Algebra</b> .....	<b>110</b>
<b>Model exams Geometry</b> .....	<b>116</b>

**Ghiyath al-Din Ibn Masoud al-kashi****(1380 AD - 1436 AD)**

Al-kashi invented the “decimal fractions”.  
Also he put a theory concerning the natural numbers raised to the fourth power.  
He reached a very accurate rate for approximately ratio  $\pi$  that nearly equates the accuracy of the calculators.

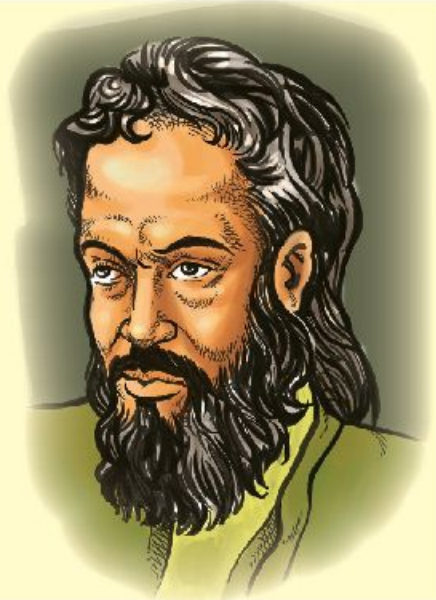
**CONTENTS**

- Lesson 1 Repeated multiplication.
- Lesson 2 Non-negative Integer powers.
- Lesson 3 Negative Integer powers.
- Lesson 4 Scientific notation.
- Lesson 5 Order of operations.
- Lesson 6 The square root of a rational number.
- Lesson 7 Solving Equations.
- Lesson 8 Inequalities.
- Miscellaneous Exercises.
- Unit test

Complete the pattern:

$$\left(\frac{1}{2}\right)^1 = \frac{1}{2}$$

$$\left(\frac{1}{2}\right)^2 = \frac{1}{2} \times \frac{1}{2} = \frac{1 \times 1}{2 \times 2} = \frac{1^2}{2^2}$$

$$\left(\frac{1}{2}\right)^3 = \frac{1}{2} \times \frac{1}{2} \times \frac{1}{2} = \frac{1 \times 1 \times 1}{2 \times 2 \times 2} = \frac{1^3}{2^3}$$

$$\left(\frac{1}{2}\right)^4 = \frac{1}{2} \times \frac{1}{2} \times \frac{1}{2} \times \frac{1}{2} = \frac{1 \times 1 \times 1 \times 1}{2 \times 2 \times 2 \times 2} = \frac{1^4}{2^4}$$

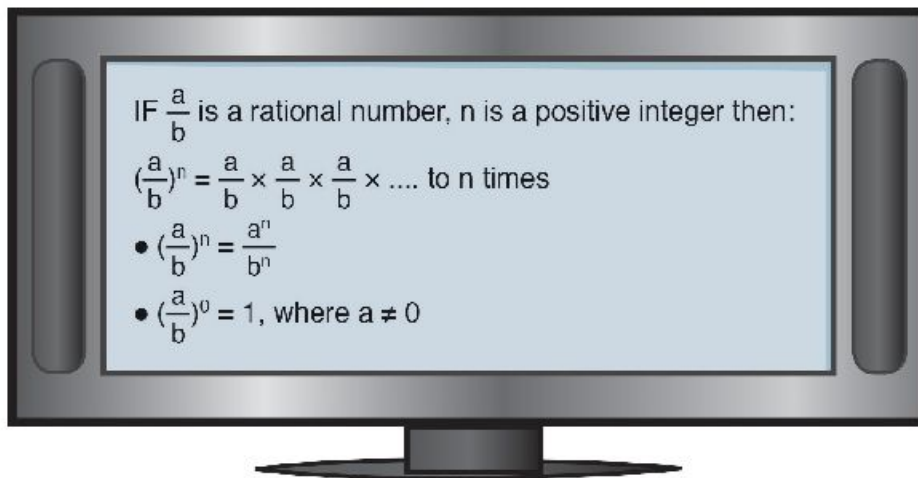

**Examples and Exercises:**

1 Calculate and express in the simplest form:

[a]  $\left(-\frac{4}{5}\right)^3$

[b]  $\left(-2\frac{1}{3}\right)^2$

[c]  $\left(2\frac{1}{4}\right)^2 \times \left(-\frac{2}{3}\right)^2$

[d]  $\left(-\frac{25}{9}\right) \div \left(-\frac{5}{9}\right)^2$

**The Solution:**

[a]  $\left(-\frac{4}{5}\right)^3 = -\frac{4^3}{5^3} = -\frac{64}{125}$ .

[b]  $\left(-2\frac{1}{3}\right)^2 = \left(-\frac{7}{3}\right)^2 = \left(\frac{7}{3}\right)^2 = \frac{49}{9}$ .

[c]  $\left(2\frac{1}{4}\right)^2 \times \left(-\frac{2}{3}\right)^2 = \left(\frac{9}{4}\right)^2 \times \left(\frac{2}{3}\right)^2 = \frac{81}{16} \times \frac{4}{9} = \frac{9}{4}$ .

[d]  $\left(-\frac{25}{9}\right) \div \left(-\frac{5}{9}\right)^2 = -\frac{25}{9} \div \left(\frac{5}{9}\right)^2 = -\frac{25}{9} \div \frac{25}{81} = -\frac{25}{9} \times \frac{81}{25} = -9$ .



2 Complete using the rule of signs in multiplication:

$$[a] \left(-\frac{2}{3}\right)^2 = \left(-\frac{2}{3}\right) \times \left(-\frac{2}{3}\right) = \dots\dots\dots$$

$$[e] \left(1\frac{1}{2}\right)^4 = \left(\frac{3}{2}\right)^4 = \dots\dots\dots$$

$$[b] \left(-\frac{2}{3}\right)^3 = \left(-\frac{2}{3}\right) \times \left(-\frac{2}{3}\right) \times \left(-\frac{2}{3}\right) = \dots\dots\dots$$

$$[f] \left(-2\frac{1}{3}\right)^2 = \left(-\frac{7}{3}\right)^2 = \dots\dots\dots$$

$$[c] \left(-\frac{2}{3}\right)^4 = \frac{2^4}{3^4} = \dots\dots\dots$$

$$[g] (2x)^2 \times \frac{1}{x} = \dots\dots\dots$$

$$[d] \left(-\frac{2}{3}\right)^5 = -\frac{2^5}{3^5} = \dots\dots\dots$$

$$[h] \left(\frac{a}{b}\right)^2 \times \frac{b^2}{c} = \dots\dots\dots$$

3 Calculate and express in the simplest form:

$$[a] \left(2\frac{1}{2}\right)^2 \times \left(-\frac{2}{5}\right)^2$$

$$= \left(\frac{5}{2}\right)^2 \times \left(\frac{2}{5}\right)^{\dots\dots\dots}$$

$$= \dots\dots\dots = \dots\dots\dots$$

$$[b] \left(2\frac{7}{9}\right) \div \left(-1\frac{2}{3}\right)^2$$

$$= \left(\frac{25}{9}\right) \div \left(-\frac{5}{3}\right)^2$$

$$= \left(\frac{5}{3}\right)^{\dots\dots\dots} \times \dots\dots\dots = \dots\dots\dots$$

### Exercise (1-1)

1 Calculate the following, then put the result in the simplest form.

[a]  $(\frac{1}{3})^4$

[e]  $(-\frac{3}{5})^3 \times (-\frac{25}{27})$

[i]  $(\frac{5a}{b})^2 \times (-\frac{2ab}{15})$

[b]  $(-\frac{3}{4})^4$

[f]  $(-\frac{1}{2})^3 \times (\frac{4}{3})^2$

[j]  $(-\frac{2}{3})^3 \times (\frac{1}{3})^3 \div (-\frac{2}{9})^2$

[c]  $(\frac{2}{3})^4$

[g]  $(-\frac{3}{4})^2 \times \frac{8}{27}$

[k]  $[(\frac{5}{2})^3 \div (\frac{3}{2})^4] \times (\frac{3}{5})^3$

[d]  $(-\frac{1}{7})^3$

[h]  $(-\frac{5}{6})^2 \div 3\frac{3}{4}$

[l]  $(-\frac{1}{2})^3 \div [8 \times (-\frac{1}{2}) \times \frac{3}{4}]$

2 [a] Find the area of a square whose side length is  $\frac{2x}{7}$

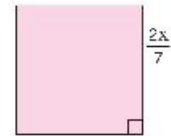

[b] Find the volume of a cube whose edge length is  $\frac{4n}{5}$

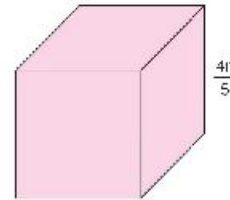

3 If  $x = -\frac{3}{2}$ ,  $y = \frac{1}{2}$ , and  $z = -\frac{4}{3}$ , then find the numerical value of each of the following in its simplest form:

[a]  $x^2 y^2 z^2$

[d]  $9xy^3 + 4y^2z^2$

[b]  $x^2 \div z^2$

[e]  $\frac{x^2 y^2 z^2}{x+y}$

[c]  $x^2 - yz^2$

[f]  $\frac{2}{3}z^3 - \frac{8}{3}x^3y - \frac{9}{2}z^2y^3$

## Lesson 2

## Non-negative Integer powers

- If a multiplication contains powers of the same base, the product may be written as a single power of that base.

**For example:**  $(\frac{1}{2})^2 \times (\frac{1}{2})^3 = (\frac{1}{2} \times \frac{1}{2}) \times (\frac{1}{2} \times \frac{1}{2} \times \frac{1}{2})$   
 $= \frac{1}{2} \times \frac{1}{2} \times \frac{1}{2} \times \frac{1}{2} \times \frac{1}{2} = (\frac{1}{2})^5$

Use the calculator to verify each of the following:

The rational number: $\frac{a}{b}$	n	m	$(\frac{a}{b})^n \times (\frac{a}{b})^m$	$(\frac{a}{b})^{n+m}$
$\frac{1}{3}$	2	3	$\frac{1}{243}$	$\frac{1}{243}$
$\frac{1}{4}$	2	3		
$\frac{1}{5}$	3	2		
$\frac{3}{2}$	3	4		

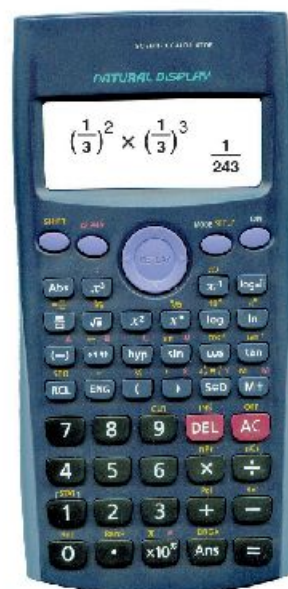

- Insert another rational numbers and another values of  $\frac{a}{b}$ , n and m
- Did you get the same product?
- Does the law apply to negative bases?

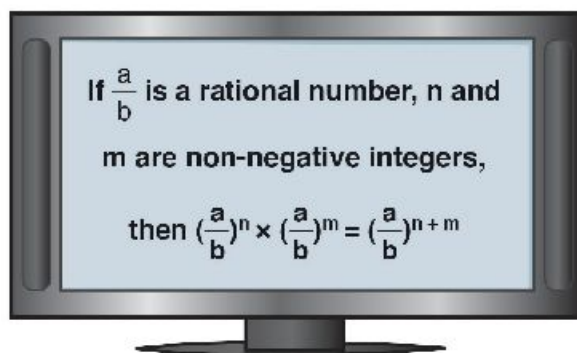

### Example :

Find the result of each the following in the simplest form :

$$[a] \left(-\frac{2}{3}\right)^2 \times \left(\frac{2}{3}\right)^5 \qquad [b] \left(-\frac{3}{5}\right)^3 \times \left(-\frac{3}{5}\right)^5$$

**The Solution:**

$$\begin{aligned} [a] \left(-\frac{2}{3}\right)^2 \times \left(\frac{2}{3}\right)^5 &= \left(\frac{2}{3}\right)^2 \times \left(\frac{2}{3}\right)^5 \\ &= \left(\frac{2}{3}\right)^{2+5} \\ &= \left(\frac{2}{3}\right)^7 \end{aligned}$$

$$\begin{aligned} [b] \left(-\frac{3}{5}\right)^3 \times \left(-\frac{3}{5}\right)^5 &= \left(-\frac{3}{5}\right)^{3+5} \\ &= \left(-\frac{3}{5}\right)^8 \\ &= \left(\frac{3}{5}\right)^8 \end{aligned}$$

- If the division operation contains rational numbers have the same base, it's possible to write the quotient with the same base.

$$\begin{aligned} \left(\frac{1}{2}\right)^5 \div \left(\frac{1}{2}\right)^3 &= \frac{\frac{1}{2} \times \frac{1}{2} \times \frac{1}{2} \times \frac{1}{2} \times \frac{1}{2}}{\frac{1}{2} \times \frac{1}{2} \times \frac{1}{2}} \\ &= \frac{1}{2} \times \frac{1}{2} = \left(\frac{1}{2}\right)^2 \end{aligned}$$

Use the calculator to verify the following.

The rational number: $\frac{a}{b}$	n	m	$\left(\frac{a}{b}\right)^n \div \left(\frac{a}{b}\right)^m$	$\left(\frac{a}{b}\right)^{n-m}$
$\frac{1}{3}$	6	4	$\frac{1}{9}$	$\frac{1}{9}$
$\frac{1}{4}$	5	2		
$\frac{1}{5}$	6	3		
$\frac{3}{2}$	7	4		



- Insert another rational numbers and another values of  $\frac{a}{b}$ ,  $n$  and  $m$
- Did you get the same quotient?
- Does the law apply to negative bases?

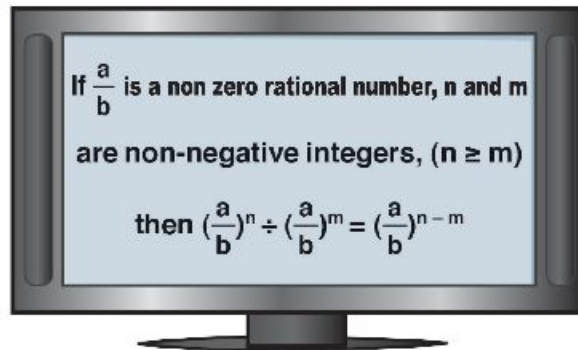

### Example :

Find the result of the following in the simplest form :

$$[a] \left(\frac{3}{4}\right)^5 \div \left(-\frac{3}{4}\right)^2$$

$$[b] \left(\frac{2}{5}\right)^{13} \div \left(\frac{2}{5}\right)^{11}$$

**The Solution:**

$$\begin{aligned}
 [a] \left(\frac{3}{4}\right)^5 \div \left(-\frac{3}{4}\right)^2 &= \left(\frac{3}{4}\right)^5 \div \left(\frac{3}{4}\right)^2 & [b] \left(\frac{2}{5}\right)^{13} \div \left(\frac{2}{5}\right)^{11} \\
 &= \left(\frac{3}{4}\right)^{5-2} & &= \left(\frac{2}{5}\right)^{13-11} \\
 &= \left(\frac{3}{4}\right)^3 & &= \left(\frac{2}{5}\right)^2 \\
 &= \frac{27}{64} & &= \frac{4}{25}
 \end{aligned}$$

- It's possible to write the rational number  $[(\frac{1}{2})^4]^2$  in the form.

$$[(\frac{1}{2})^4]^2 = (\frac{1}{2})^4 \times (\frac{1}{2})^4$$

$$= (\frac{1}{2})^{4+4} = (\frac{1}{2})^8$$

Use the calculator to find the following:

The rational number: $\frac{a}{b}$	n	m	$((\frac{a}{b})^n)^m$	$(\frac{a}{b})^{n \times m}$
$\frac{1}{3}$	2	3	$\frac{1}{729}$	$\frac{1}{729}$
$\frac{1}{4}$	3	2		
$\frac{1}{5}$	2	4		
$\frac{3}{2}$	3	2		

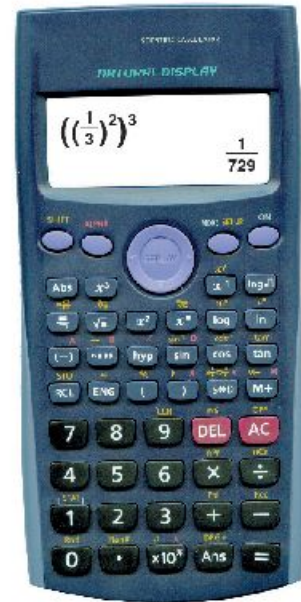

- Insert rational numbers using other values of  $\frac{a}{b}$ , n and m
- Is the output in the fourth column equal to the output in the fifth column?

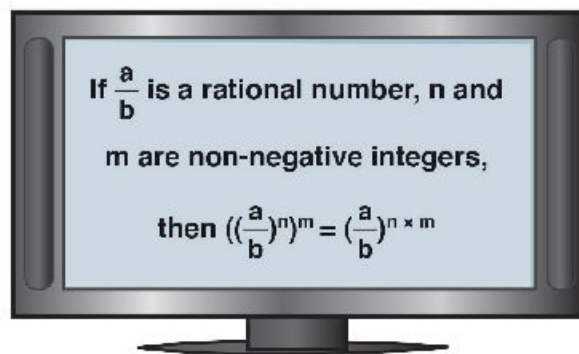

**Example :**

Find the result of each the following:

$$[a] \left[ \left( \frac{3}{4} \right)^2 \right]^2 \quad [b] \left[ \left( \frac{-1}{2} \right)^2 \right]^3$$

**The Solution:**

$$\begin{aligned} [a] \left[ \left( \frac{3}{4} \right)^2 \right]^2 &= \left( \frac{3}{4} \right)^4 \\ &= \frac{3^4}{4^4} \\ &= \frac{81}{256} \end{aligned}$$

$$\begin{aligned} [b] \left[ \left( \frac{-1}{2} \right)^2 \right]^3 &= \left( -\frac{1}{2} \right)^6 \\ &= \left( \frac{1}{2} \right)^6 \\ &= \frac{1^6}{2^6} \\ &= \frac{1}{64} \end{aligned}$$

● Use the previous steps to verify that:

$$[a] \left( \frac{a}{b} \right)^n \times \left( \frac{c}{d} \right)^n = \left( \frac{a}{b} \times \frac{c}{d} \right)^n$$

$$[b] \left( \frac{a}{b} \right)^n \div \left( \frac{c}{d} \right)^n = \left( \frac{a}{b} \div \frac{c}{d} \right)^n = \left( \frac{ad}{bc} \right)^n$$

### Exercise (1-2)

**1** Calculate each of the following, then put the result in the simplest form:

[a]  $(\frac{2}{3})^3 \times (\frac{2}{3})^2$

[e]  $(-\frac{b^2}{a})^2$

[i]  $[(2\frac{1}{2})^3]^2$

[b]  $(-\frac{2}{3})^3 \times (\frac{2}{3})^2$

[f]  $(-\frac{x^3}{y^2})^2$

[j]  $(\frac{x^2}{y^3})^2$

[c]  $[(-\frac{3}{2})^2]^5$

[g]  $(\frac{2}{7})^5 \div (\frac{2}{7})^3$

[k]  $(-\frac{c^2}{d})^3$

[d]  $(\frac{ab}{c})^5$

[h]  $(-\frac{3}{5})^7 \div (\frac{3}{5})^5$

[l]  $(-\frac{xy^8}{z^2})^2$

**2** If  $x = -\frac{1}{2}$ ,  $y = \frac{3}{4}$  and  $z = -\frac{3}{2}$  then,

Find the numerical value of each of the following in the simplest form:

[a]  $x^3y^2$

[b]  $y^3x^2$

[c]  $x^3 \div y^2z^2$

[d]  $(\frac{xy}{z})^5$

[e]  $(\frac{x^2}{y^3})^2$

[f]  $(\frac{y^2}{x})^2$

**3** Match each expression in column 1 with an equivalent expression in column 2:

**Column [1]**

[1]  $(x^2)^n$

[2]  $(x^n)^n$

[3]  $(xy^a)^b$

[4]  $(\frac{x}{y^a})^5$

[5]  $(-3x^a)^3$

[6]  $(3x^a)^3$

[7]  $\frac{3}{2} (\frac{m}{n})^c$

[8]  $(\frac{3m}{2n})^c$

**Column [2]**

[a]  $x^{n^2}$

[b]  $\frac{3m^c}{2n^c}$

[c]  $27x^{3a}$

[d]  $\frac{3^a m^c}{2^c n^c}$

[e]  $x^{2n}$

[f]  $-27x^{3a}$

[g]  $\frac{n^b}{y^{ab}}$

[h]  $x^b y^{ab}$

[i]  $\frac{x^b}{y^{ab}}$

[j]  $xy^{ab}$





## Lesson 3

## Negative Integer powers

- We know the meaning of the positive power of a rational number as well as the meaning of the zero power. Now we are going to know the meaning of the negative integer power of a rational number:

$$\begin{aligned}
 2^2 &\xrightarrow{-1} 2^1 = 2^2 \xrightarrow{+2} 2^2 \\
 2^1 &\xrightarrow{-1} 2^0 = 2^1 \xrightarrow{+2} 2^1 \\
 2^0 &\xrightarrow{-1} 2^{-1} = 2^0 \xrightarrow{+2} 2^0 \\
 2^{-1} &\xrightarrow{-1} 2^{-2} = 2^{-1} \xrightarrow{+2} 2^{-1} \\
 2^{-2} &= \frac{1}{2^2}
 \end{aligned}$$

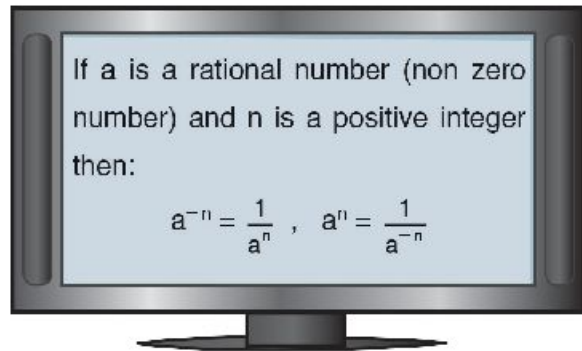

Note that:  $a^n \times a^{-n} = a^{n+n} = a^0 = 1$  each of  $a^n$  and  $a^{-n}$  is a multiplicative inverse for the other.

- Example:** Find the value of each of the following

$$[1] 5^6 \times 5^{-4} = \frac{5^6}{5^4} = 5^2 \quad [2] \frac{7^{-3}}{7^{-2}} = \frac{7^2}{7^3} = 7^{-1} = \frac{1}{7}$$

$$\begin{aligned}
 [3] \left(\frac{6^{-2} \times 6^4}{6^3}\right)^{-2} &= \left(\frac{6^4}{6^3 \times 6^2}\right)^{-2} \\
 &= \left(\frac{6^4}{6^5}\right)^{-2} = \left(\frac{1}{6}\right)^{-2} = 6^2 = 36
 \end{aligned}$$

- Use the table of powers of 5 to evaluate these expressions.

**Example:**

$$[1] 15625 \times 0.0016 = 5^6 \times 5^{-4} = \dots\dots\dots$$

$$[2] 0.00032 \times 3125 \quad [3] (78125)^{-1}$$

$$[4] (0.0016)^2 \quad [5] \frac{0.008}{625}$$

$$[6] \frac{125}{0.00032} \quad [7] \frac{(3125)^2}{15625}$$

$$[8] (0.0000128)^3 \times (390625)^2$$

Table of powers of 5

$5^1 = 5$	$5^{-1} = 0.2$
$5^2 = 25$	$5^{-2} = 0.04$
$5^3 = 125$	$5^{-3} = 0.008$
$5^4 = 625$	$5^{-4} = 0.0016$
$5^5 = 3125$	$5^{-5} = 0.00032$
$5^6 = 15625$	$5^{-6} = 0.000064$
$5^7 = 78125$	$5^{-7} = 0.0000128$
$5^8 = 390625$	$5^{-8} = 0.00000256$
$\vdots$	$\vdots$

### Exercise (1-3)

#### 1 Complete:

$$[a] \frac{5}{5^{-3}} = 5^{1 + (-3)} = 5^{\dots}$$

$$[e] 5c^0 = \dots$$

$$[b] (b^{-1})^3 = b^{\dots}$$

$$[f] 2x^{-3} = \frac{2}{\dots}$$

$$[c] (3x^{-1})^2 = 9x^{\dots} = \frac{9}{\dots}$$

$$[g] (3a^2)^{-1} = \frac{1}{\dots}$$

$$[d] 10^{-3} = \frac{1}{\dots}$$

$$[h] 2x^{-2}y^{-3} = \frac{2}{\dots}$$

#### 2 Evaluate:

$$[a] 5^{-1}$$

$$[e] 4^{-2} \times 4^5$$

$$[i] \frac{3}{3^{-2}}$$

$$[m] \left(\frac{3^{-1}}{3}\right)^2$$

$$[b] 4^{-1}$$

$$[f] 3^7 \times 3^{-3}$$

$$[j] \frac{6^{-2}}{6^{-3}}$$

$$[n] \left(\frac{8^4}{8^4}\right)^0$$

$$[c] 5^{-2}$$

$$[g] (3^{-2})^{-2}$$

$$[k] \frac{8 \times 8^{-2}}{8^{-3}}$$

$$[o] \left(\frac{9^3 \times 9}{9^5}\right)^3$$

$$[d] 4^{-2}$$

$$[h] (5^{-1})^{-3}$$

$$[l] \frac{7^{-2} \times 7^5}{7^3}$$

$$[p] \left(\frac{4^{-2} \times 3}{4^{-5}}\right)^{-3}$$

#### 3 Simplify and write the result in terms of a positive exponent:

$$[a] 7x^{-1}$$

$$[e] (b^{-1})^{-3}$$

$$[i] \frac{c^{-5}}{c^2}$$

$$[m] \left(\frac{n^{-3}}{n}\right)^{-2}$$

$$[b] x^{-1}y^2$$

$$[f] x^3 \times x^{-5}$$

$$[j] \frac{d^{-3}}{d^{-5}}$$

$$[n] \left(\frac{y^5}{y^{-2}}\right)^{-1}$$

$$[c] a^{-2}b^{-3}$$

$$[g] (a^2 \times a^{-5})^2$$

$$[k] \left(\frac{x^{-2}}{x^{-4}}\right)^1$$

$$[o] (3^0 - 2^{-2})^{-2}$$

$$[d] (a^{-2})^3$$

$$[h] \frac{a^b}{a^{-3}}$$

$$[l] \left(\frac{a^{-1}}{a^4}\right)^2$$

$$[p] (3^0 \times 2^{-2})^{-2}$$

#### 4 Why $b^{-3}$ is not defined when $b=0$ ?

#### 5 The population of a city has been growing exponentially. It is estimated that in $t$ years

the population  $p$  will be:  $P = 2(1.03)^t$  million people.

[a] What will the population be after 2 years?

[b] What is the population now?

[c] What was the population last year?



## Lesson 4

## Scientific Notation

Professor Zewail is the Director of the Laboratory for molecular sciences at California Institute of Technology. In 1997, he discovered the femto second, which is a millionth of a milliardth of a second ( $1 \times 10^{-15}$ ). In 1999, he was awarded the Nobel Prize for chemistry.



- Some numbers are so large or so small that they are difficult to read or to write.

**For example:** the diameter of the solar system: 118 000 000 000 km.

The diameter of a silver atom: 0.000 000 000 000 25 km.

- Scientific notation makes it easier to read values and helps calculating with such numbers.

## Example

Express each number in scientific notation:

$a \times 10^n$  where  $n \in \mathbf{Z}$

[a] 58 120 000 000

[b] 0.000 000 072

[c] - 0.000 053

**Solution:**

[a] The decimal point must be placed

here ↓

5 8 120 000 000

Such that  $1 \leq a < 10$

So we divide the number by  $10^{10}$

$$\begin{aligned} 58\,120\,000\,000 &= 5.812 \times 10^{10} \\ &= 5.8 \times 10^{10} \end{aligned}$$

[c] - 0.000 053 = - 5.3  $\times 10^{-5}$

To express a number in a standard scientific notation, write it in this form

$$a \times 10^n \quad 1 \leq |a| < 10 \text{ and } n \in \mathbf{Z}$$

### Exercise (1–4)

**1** Identify the numbers which are not in the standard form  $a \times 10^n$ ,  $n \in \mathbf{Z}$ :

[a]  $6.2 \times 10^5$

[c]  $7.834 \times 10^{16}$

[e]  $0.8 \times 10^5$

[b]  $0.46 \times 10^7$

[d]  $82.3 \times 10^6$

[f]  $6.75 \times 10^1$

**2** Write the following numbers in the standard form  $a \times 10^n$ ,  $n \in \mathbf{Z}$ :

[a] 600000

[c] 7 million

[e] 0.000053

[b] 48000000

[d] 0.0006

[f] 0.000864

**3** Write the following numbers in the standard form  $a \times 10^n$ ,  $n \in \mathbf{Z}$ :

[a]  $68 \times 10^5$

[c]  $0.75 \times 10^9$

[e]  $750 \times 10^{-9}$

[b]  $720 \times 10^6$

[d]  $68 \times 10^{-5}$

[f]  $0.4 \times 10^{-10}$

**4** Write the result of each if the following in the form of  $a \times 10^n$ ,  $n \in \mathbf{Z}$ :

[a]  $(4.4 \times 10^3) \times (2 \times 10^5)$

[c]  $(3.8 \times 10^5) + (4.6 \times 10^4)$

[b]  $(3.8 \times 10^8) \div (1.9 \times 10^6)$

[d]  $(5.3 \times 10^8) - (8.0 \times 10^7)$

**5** The light of the Sun takes approximately 8 minutes to reach the earth. If light travels at a speed of  $3 \times 10^8$  m/s,

[a] Calculate the distance from the Sun to the Earth.

[b] If the distance between Venus planet and the Sun is 108 million kilometer. Calculate the time elapsed in minutes that light takes to reach Venus from the Sun.

**6** Arrange the following numbers in a descending order:

$3.6 \times 10^{-3}$

$5.2 \times 10^{-5}$

$1 \times 10^{-2}$

$8.35 \times 10^{-2}$

$6.08 \times 10^{-8}$

**7** Find the value of  $n$  in each case:

[a]  $0.00025 = 2.5 \times 10^n$

[b]  $0.000357 = 3.57 \times 10^n$

[c]  $0.00000006 = 6 \times 10^n$

[d]  $(0.004)^2 = 1.6 \times 10^n$



## Lesson 5

## Order of operations

Scientific calculators follow the rules for order of operations. When expressions have no parentheses, enter the numbers and operations in order from left to right. What do you notice?

1)  $12 - 6 \times 2$

$$12 \text{ [ - ] } 6 \text{ [ x ] } 2 \text{ [ = ] } \boxed{0}$$

2)  $8 + 15 \div 3$

$$8 \text{ [ + ] } 15 \text{ [ \div ] } 3 \text{ [ = ] } \boxed{13}$$

3)  $9^5$

$$9 \text{ [ x^y ] } 5 \text{ [ = ] } \boxed{59049}$$



Complete the table:

Expression	Meaning	Value
$4 \times 7 + 9$	Multiply 4 by 7 then add 9	$4 \times 7 + 9 = 28 + 9 = 37$
$2 \times 5 + 9$	Multiply ... by ... then add ...	.....
$16 + 10 \div 2$	divide 10 by 2 then add 16	$16 + 10 \div 2 = 16 + 5 = 21$
$3(5 + 6)$	add ... and ... then ..... by 3	.....
$3\left(\frac{7-5}{6 \div 2}\right)$	Subtract ... from ..., divide 6 by 2 then multiply by ...	.....
$\left(\frac{1}{6}\right)^4$	The fourth power of .....	$\left(\frac{1}{6}\right)^4 = \frac{1}{\dots}$
$3c^2$	When there are no parentheses, an exponent	$3c^2 = 3 \times c \times c = \dots$
$(3c)^2$	refers to the base directly to its left.	$(3c)^2 = 3c \times \dots = \dots$

- 1) Perform the operations within parentheses or grouping symbols
- 2) Evaluate powers.
- 3) perform multiplications and divisions in order from left to right.
- 4) perform additions and subtractions in order from left to right.

## Exercise (1-5)

### 1 Evaluate:

$[a] 3 + [5 + 2(8 \div 4)]$

$[e] 9 + 4 \times 3^2$

$[i] 144 - 8 \div 2^3$

$[b] 2^3 + [4 + (2 - 1)]$

$[f] 196 \div (7 - 5)^2$

$[j] 4 \times 2^3 - 20$

$[c] 7(6^2 \div 2 \times 3)$

$[g] 4 \times 7 - 3^2$

$[k] 12(2^2) \div 24 + 3^2$

$[d] 2 \times 6 - 4 \div 2$

$[h] 1^5 + 6^3 - 5^2$

$[l] 9(4)^2 \div 2^2 \times 3$

### 2 Simplify:

$[a] 2 - [(7 - 3) - 2]$

$[e] 2 [(5^2 + 1) - (4^2 - 1)]$

$[b] [4 - (5 - 2)] - 1$

$[f] 5 [(2^2 - 1) - (2^2 - 2)]$

$[c] \frac{15 + 7}{15 - 4}$

$[g] \frac{5 + 2 \times 5}{2^2 + 1} + 5^2 - 5$

$[d] \frac{8 + 20 - 4}{8 - 4}$

$[h] \frac{3^2 \times 6 \div 3}{2 \times 1 \div (3 + 1)^2}$

### 3 Evaluate the expressions when $t = 2$ and $s = 5$ :

$[a] (t + s)^2$

$[c] \left(\frac{s}{t}\right)^3$

$[e] \frac{s - t}{s^3}$

$[b] (s - t)^3$

$[d] \frac{6^2}{s - 1}$

$[f] \frac{12}{4s^2}$

### 4 [a] Evaluate $16t \div 4s + 3st$ for $t = 9$ and $s = 6$ :

[b] The total area of a cube is  $T = 6s^2$  find  $T$  When,

[1]  $s = 3\text{m}$ .

[2]  $s = 0.8\text{ cm}$ .

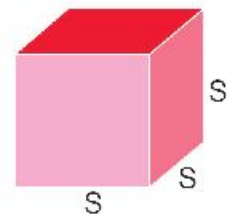

### 5 Area of a trapezium is $A = \frac{1}{2}h(a + b)$ . Find $A$ when:

[a]  $h = 2$  metres,  $a = \frac{3}{4}$  metre,  $b = \frac{1}{4}$  metre.

[b]  $h = 4$  metres,  $a = \frac{1}{4}$  metre,  $b = \frac{1}{2}$  metre.

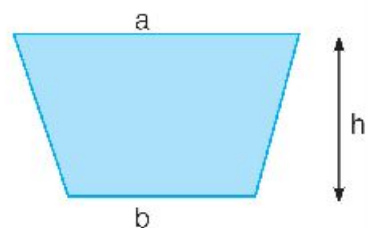

## Lesson 6

## The square root of a rational number

To square a number, you multiply it by itself:  $5^2 = 5 \times 5 = 25$

The inverse operation is taking the square root.

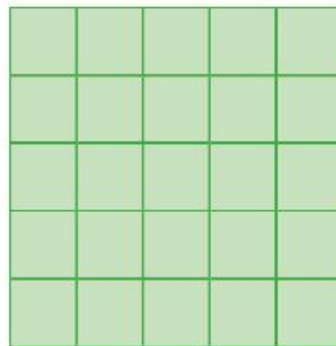
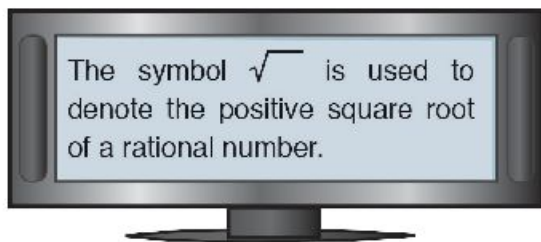

$$\sqrt{25} = 5$$

$\Rightarrow$  each of  $\sqrt{25}$  and  $-\sqrt{25}$  means the two square roots of 25

$$-\sqrt{25} = -5$$

## Notice

It is meaning less to find  $\sqrt{\frac{a}{b}}$ , if  $\frac{a}{b} < 0$  (negative),  $\sqrt{\left(\frac{a}{b}\right)^2} = \left|\frac{a}{b}\right|$  where  $\left|\frac{a}{b}\right| \geq 0$

## Drill

Complete:

[a]  $\sqrt{400} = \sqrt{20^2} = \dots$

[d]  $\sqrt{\left(\frac{-2}{3}\right)^2} = \sqrt{\frac{\dots}{\dots}} = \dots$

[b]  $-\sqrt{\frac{144}{49}} = -\sqrt{\left(\frac{\dots}{\dots}\right)^2} = \dots$

[e]  $\sqrt{\left(\frac{3}{25}\right)^2} = |\dots| = \dots$

[c]  $\sqrt{\left(\frac{2}{3}\right)^2} = \sqrt{\frac{4}{9}} = \dots$

[f]  $\sqrt{\left(\frac{-3}{25}\right)^2} = |\dots| = \dots$

## Example

In the triangle ABC, if  $(AB)^2 = 16 \text{ cm}^2$ ;  $(BC)^2 = 25 \text{ cm}^2$

find  $AB + BC$

**Solution:**

$$(AB)^2 = 16$$

$$(BC)^2 = 25$$

$$AB = \sqrt{16}$$

$$BC = \sqrt{25}$$

$$AB = 4 \text{ cm}$$

$$BC = 5 \text{ cm}$$

$$\therefore AB + BC = 4 + 5 = 9 \text{ cm.}$$

### Exercise (1– 6)

**1** Find the two square roots of each of the following numbers:

[a] 64

[c] 121

[e]  $\frac{25}{36}$

[b]  $\frac{1}{4}$

[d] 10000

[f]  $\frac{9}{100}$

**2** Simplify each of the following to the simplest form:

[a]  $\sqrt{16}$

[e]  $-\sqrt{4^2}$

[i]  $\pm\sqrt{\frac{25}{36}}$

[m]  $-\sqrt{\frac{49a^4}{25b^6}}$

[b]  $-\sqrt{25}$

[f]  $\pm\sqrt{8^2}$

[j]  $-\sqrt{\frac{64}{25}}$

[n]  $\pm\sqrt{\frac{16b^8}{121h^2}}$

[c]  $\pm\sqrt{1.44}$

[g]  $\sqrt{\frac{9}{49}}$

[k]  $\pm\sqrt{\frac{144}{169}}$

[o]  $\sqrt{\frac{49a^4b^2}{9}}$

[d]  $\pm\sqrt{40000}$

[h]  $\sqrt{\frac{4}{81}}$

[l]  $\sqrt{\left(\frac{81}{100}\right)^2}$

[p]  $\sqrt{\frac{25x^2y^2}{36}}$

**3**  $\overline{XY}$  is a line segment such that  $(xy)^2 = 25$ , Z is midpoint of  $\overline{XY}$ . Calculate the length of  $\overline{XZ}$ .

**4** If  $(AB)^2 = 144$  ,  $(BC)^2 = 625$  and  $B \in \overline{AC}$   
find the length of  $\overline{AC}$ .





## Lesson 7 Solving Equations

Solving equation of the first degree in one unknown:

Study the following equations:

$$2x + 2 = 8 \quad \text{.....} \quad (1)$$

$$2x + 5 = 11 \quad \text{.....} \quad (2)$$

$$2x = 6 \quad \text{.....} \quad (3)$$

$$6x = 18 \quad \text{.....} \quad (4)$$

$$3x = 9 \quad \text{.....} \quad (5)$$

The previous equations have the same solution, i.e.  $x = 3$

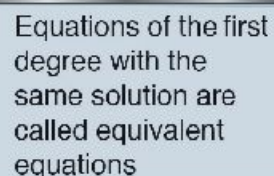

Equations of the first degree with the same solution are called equivalent equations

Complete:

- 1 If we add 3 to both sides of equation (1), we obtain equation (2)
- 2 If we subtract 5 from both sides of equation (2), we obtain equation (.....)
- 3 If we multiply both sides of equation (3) by 3, we obtain equation (.....)
- 4 If we divide both sides of equation (4) by 2, we obtain equation (.....)

Thus we can sum up our observations as follows:

The new equation obtained is equivalent to the original equation when:

- We add to or subtract from both sides of the equation the same number,
- We multiply or divide both sides of the equation by the same non - zero number.

Generally

If  $a$ ,  $b$  and  $c$  are rational numbers, and  $a = b$ , then

$$a + c = b + c$$

$$a \times c = b \times c$$

If  $a + c = b + c$ , then  $a = b$

If  $a \times c = b \times c$ , and  $c \neq \text{zero}$ , then  $a = b$

### Example 1

Solve  $x + 21 = 8$  in  $Z$

**Solution**

$$x + 21 = 8 \quad \longleftarrow \text{Add } (-21) \text{ to each side}$$

$$\begin{array}{r} x + 21 + (-21) = 8 + (-21) \\ \downarrow \qquad \qquad \downarrow \\ x + 0 = -13 \end{array}$$

$$x = -13 \in Z$$

the solution set =  $\{-13\}$

What is the number that should be added to both sides of the equation  $x + 21 = 8$  to get the value of  $x$ ?

### Example 2

Solve :  $x - 3\frac{1}{2} = 5$  in  $Q$

**Solution**

$$x + (-3\frac{1}{2}) + 3\frac{1}{2} = 5 + 3\frac{1}{2}$$

$$x = 8\frac{1}{2} \in Q$$

the solution set =  $\{8\frac{1}{2}\}$

Think:  $x - 3\frac{1}{2} = x + (-3\frac{1}{2})$  So add  $3\frac{1}{2}$ , the additive inverse of  $-3\frac{1}{2}$ , to each side of the equation.

### Example 3

Solve the equation  $5x + 8 = 13 - 2x$ , where  $x \in Q$

**Solution**

$$5x + 8 = 13 - 2x$$

$$5x + 8 + 2x = 13 - 2x + 2x \quad \longleftarrow \text{Add } 2x \text{ to both sides.}$$

$$7x + 8 = 13$$

$$7x + 8 - 8 = 13 - 8 \quad \longleftarrow \text{Subtract } 8 \text{ from both sides.}$$

$$7x = 5 \quad \longleftarrow \text{Divide both sides by } 7.$$

$$x = \frac{5}{7}, \quad x = \frac{5}{7} \in Q, \text{ the solution set} = \{\frac{5}{7}\}$$



**Example 4**

Solve the equation  $3(3 - 2x) - (1 + x) = 10 - 13x$ , where  $x \in \mathbb{Q}$

**Solution**

$$3(3 - 2x) - (1 + x) = 10 - 13x \quad \longleftarrow \text{Use the distributive property}$$

$$9 - 6x - 1 - x = 10 - 13x \quad , \quad 8 - 7x = 10 - 13x$$

$$8 - 7x + 13x = 10 - 13x + 13x \quad \longleftarrow \text{Add } 13x \text{ to both sides.}$$

$$8 + 6x = 10$$

$$8 - 8 + 6x = 10 - 8 \quad \longleftarrow \text{Subtract 8 from both sides.}$$

$$6x = 2 \quad \longleftarrow \text{Divide both sides by 6.}$$

$$x = \frac{1}{3}, \quad x = \frac{1}{3} \in \mathbb{Q}, \text{ the solution set} = \left\{ \frac{1}{3} \right\}$$

**Example 5**

The length of playground is 3 metres shorter than three times the width. The perimeter is 210 metres. Find the dimensions of the playground.

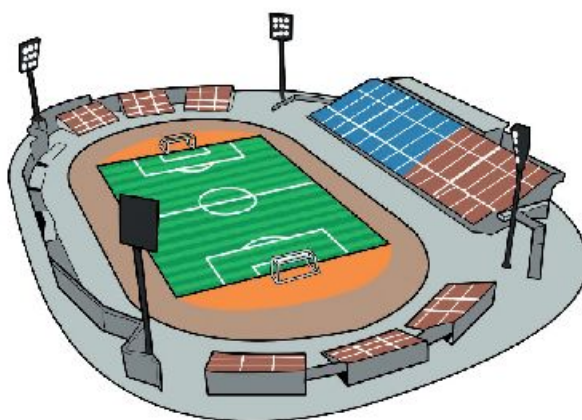
**Solution**

Let  $w$  = the width, then  
the length =  $3w - 3$ , and the playground is in the form of a rectangle whose perimeter is 210 m.

Twice the length	plus	Twice the width	Equals	The perimeter
↓	↓	↓	↓	↓
$2(3w - 3)$	+	$2w$	=	$210$

$$6w - 6 + 2w = 210$$

$$8w - 6 = 210$$

$$8w = 216$$

$$w = 27 \quad \longleftarrow \text{The width} = 27 \text{ metres.}$$

The length =  $3w - 3 = 3(27) - 3 = 78$  metres.

$$\begin{aligned} \text{Check: perimeter of the rectangle} &= \text{twice the length} + \text{twice the width} \\ &= 2 \times 78 + 2 \times 27 \\ &= 156 + 54 = 210 \end{aligned}$$

The width of the playground is 27 metres and the length is 78 metres.

### Example 6

The sum of the ages of 3 brothers now is 55 years. If the eldest was born before the middle by 3 years, and the middle was born before the youngest by two years, find the age of each of them.



#### Solution

Let the age the middle now =  $X$  years  
 The age of the eldest now =  $X + 3$   
 the age of the youngest now =  $X - 2$

The age of the eldest	plus	The age of the middle	plus	the age of the youngest	Equals	55
↓		↓		↓	↓	
$(X + 3)$	+	$X$	+	$(X - 2)$	=	55
$3X + 1 = 55$ $3X = 54$ $X = 18$						

Their ages are: 16, 18, and 21 years

### Example 7

In the figure opposite:  
 Find the measure of each angle  
 in the triangle ABC

#### Solution

$$m(\angle A) + m(\angle B) + m(\angle C) = 180^\circ$$

Replace A with  $2x$ , B with  $x$ , and C with  $2x + 5$

$$2x + x + 2x + 5 = 180^\circ$$

$$5x + 5 = 180^\circ$$

$$5x = 175^\circ$$

$$x = 35^\circ$$

$$m(\angle A) = 35^\circ,$$

$$m(\angle B) = 2x = 2(35) = 70^\circ, \quad \text{and} \quad m(\angle C) = 2x + 5 = 2(35) + 5 = 75^\circ$$

Check: the sum of the measures of the angles of  $\triangle ABC = 35^\circ + 70^\circ + 75^\circ = 180^\circ$

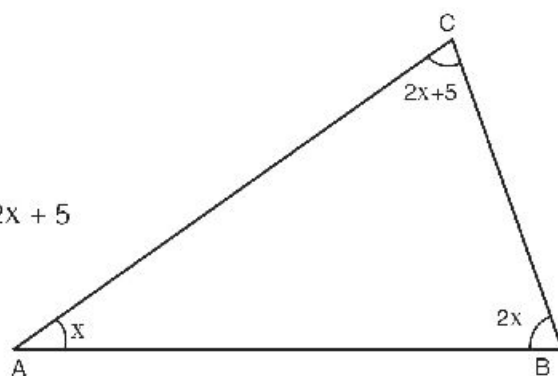

## Exercise (1-7)

**1** Solve each of the following equations:

- |  |                      |                        |                      |
|--|----------------------|------------------------|----------------------|
| [a] $x + 17 = 13$                      | , $x \in \mathbb{N}$ | [f] $3x - 13 = 26$     | , $x \in \mathbb{N}$ |
| [b] $x - 6\frac{1}{4} = 12\frac{1}{2}$ | , $x \in \mathbb{Q}$ | [g] $8 + 2x = 14$      | , $x \in \mathbb{Z}$ |
| [c] $-4 + y = 13$                      | , $y \in \mathbb{N}$ | [h] $8x + 4 = 12$      | , $x \in \mathbb{Q}$ |
| [d] $m - (-3) = 1$                     | , $m \in \mathbb{Z}$ | [i] $x + 3 = 18 - 3x$  | , $x \in \mathbb{N}$ |
| [e] $8.91 + x = 11.09$                 | , $x \in \mathbb{Q}$ | [j] $5x - 4 = 2x + 11$ | , $x \in \mathbb{Q}$ |

**2** Complete:

- [a] If  $x + 9 = 11$ , then the value of  $7x = \dots\dots$
- [b] If  $3t = 6$ , then the value of  $6t = \dots\dots$
- [c] If  $2t + 3 = 15$ , then the value of  $\frac{1}{3}t = \dots\dots$
- [d] If  $Z - 1\frac{1}{4} = 5\frac{1}{2}$ , then the value of  $4Z - 18 = \dots\dots$
- [e] If  $\frac{p}{4} = \frac{2}{3}$ , then the value of  $\frac{p}{2} = \dots\dots$

**3** Solve the following equations in  $\mathbb{Q}$ :

- |                                |                                      |
|--------------------------------|--------------------------------------|
| [a] $3(x + 2) + 7(x - 1) = 12$ | [d] $3(2x - 8) - (2x + 2) = x - 3$   |
| [b] $4(x - 1) - (x + 3) = 0$   | [e] $a + 5a - 2 = 2(3 - a)$          |
| [c] $28(x - 3) - (x - 3) = 0$  | [f] $3y + 6(y + 3) - (8y - 16) = 60$ |

**4** The sum of three consecutive even numbers is 966. Find them.

**5** A man's age now is three times his son's age, and after two years, the sum of their ages will be 52 years. What is the age of each now?

**6** Two natural numbers, one of them is twice the other, and their sum is 108. Find the two numbers.

**7** The length of a rectangle exceeds its width by 4 metres and its perimeter is 68 metres. Find the dimensions of the rectangle.

**8** The price of one metre of wool exceeds 2 Pounds than the price of one metre of silk. If the price of 3 metres of wool and 4 metres of silk is 671 pounds. Find the price of one metre of each kind.

## Solving inequalities

## Notice

- Adding the same number to each side of an inequality gives an equivalent inequality.
- Multiplying each side of an inequality by the same positive number does not change the direction of the inequality.
- Multiplying each side of an inequality by a negative number, however, reverses the direction of the inequality.

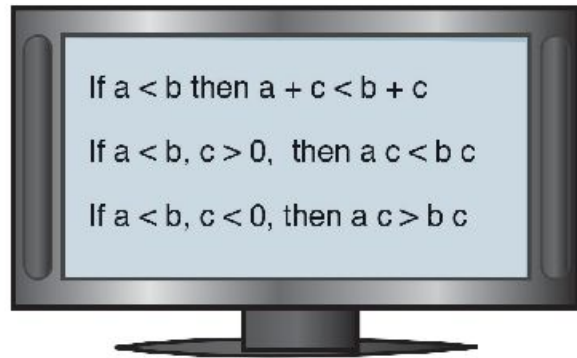

## Example 1

Solve the inequality :  $x + 5 > 3$  , (i)  $x \in \mathbb{Z}$  , (ii)  $x \in \mathbb{N}$  , then represent the solution set on the number line

What is the number that must be added to  $x + 5$  to get  $x$ ?

## Solution

$$x + 5 > 3$$

$$x + 5 + (-5) > 3 + (-5) \quad \leftarrow \text{add } (-5) \text{ to each side}$$

$$x > -2$$

(i) The solution set =  $\{-1, 0, 1, \dots\} \quad x \in \mathbb{Z}$

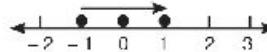

(ii) The solution set =  $\{0, 1, 2, \dots\} \quad x \in \mathbb{N}$



### Example 2

Solve the inequality:  $-2x \geq 1$ , (i)  $x \in \mathbb{Q}$ , (ii)  $x \in \mathbb{N}$ , then represent the solution set on the number line.

What is the number that multiplied by  $-2x$  to get  $x$ ?

**Solution**

$$-2x \geq 1$$

$$-\frac{1}{2} \times (-2x) \leq \left(-\frac{1}{2}\right) \times 1$$

$$x \leq -\frac{1}{2}$$

(i) The Solution set =  $\{x : x \in \mathbb{Q}, \text{ and } x \leq -\frac{1}{2}\}$  (ii) the solution set =  $\emptyset, x \in \mathbb{N}$



### Example 3

Solve the inequality:  $3x - 1 \leq 2x + 3$ ,  $x \in \mathbb{Q}$ , then represent the solution set on the number line.

**Solution**

$$3x - 1 \leq 2x + 3$$

$$-2x + 3x - 1 \leq -2x + 2x + 3 \quad \leftarrow \text{add } (-2x) \text{ to each side}$$

$$x - 1 \leq 3 \quad \leftarrow \text{add 1 to each side}$$

$$x - 1 + 1 \leq 3 + 1$$

$$x \leq 4$$

The Solution set =  $\{x : x \in \mathbb{Q}, x \leq 4\}$

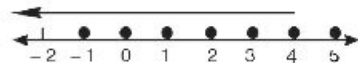

### Exercise (1-8)

#### 1 Put the suitable sign ( $<$ or $>$ ):

- [a] If  $18 > 12$ ,  $\Rightarrow 18 + (-5)$    $12 + (-5)$   
[b] If  $21 < 30$ ,  $\Rightarrow 21 + 15$    $30 + 15$   
[c] If  $12 > 3$ ,  $\Rightarrow \frac{1}{3} (12)$    $\frac{1}{3} (3)$   
[d] If  $12 < 16$ ,  $\Rightarrow (-\frac{1}{4}) (12)$    $(-\frac{1}{4}) (16)$   
[e] If  $x - 8 < 2$ ,  $\Rightarrow x - 8 + 8$    $2 + 8$ , or  $x$    $10$   
[f] If  $-\frac{1}{3}x \geq 27$ ,  $\Rightarrow (-3)(-\frac{1}{3}x)$    $(-3)(27)$ , or  $x$    $-81$

#### 2 Which number would you add to each side of the inequality to obtain $x$ ?

- [a]  $x + 5 > 9$  [e]  $x - 1.5 \leq 3.2$   
[b]  $x - 4 < 6$  [f]  $4.8 \leq x + 0.6$   
[c]  $x - 7 < 3$  [g]  $1\frac{1}{2} > x - 2\frac{1}{2}$   
[d]  $x + 9 > 12$  [h]  $x + \frac{1}{3} > -\frac{1}{6}$

#### 3 Complete:

- [a] If  $X > Y$ , then  $X + Z$    $Y + Z$   
[b] If  $X < Y$ , then  $X + Z$    $Y + Z$   
[c] If  $X < Y$  and  $Y < Z$ , then  $X <$    
[d] If  $Z > Y$  and  $Z > X$ , then  $Z >$    
[e] If  $a - 3 < 0$ , Then .....  $>$  .....  
[f] If  $a + 5 > 0$ , Then .....  $>$  .....  
[g] If  $b < 0$ , then  $b + 3$    $3$   
[h] If  $X > Y$  and  $Z$  is positive ( $Z > 0$ ), then  $XZ$    $YZ$ .  
[i] If  $X < Y$  and  $Z$  is negative ( $z < 0$ ), then  $XZ$    $YZ$ .





**4** Solve each inequality and represent the solution set on the number line:

[a]  $x + 4 > 1$

[h]  $8x - 3x + 1 \leq 29$

[b]  $y - 5 > 7$

[i]  $-3m + 6(m - 4) > 9$

[c]  $-5\frac{1}{2} > a + 1\frac{1}{4}$

[j]  $3(x + 2) < -x + 4$

[d]  $19 < y + 14$

[k]  $3(x + 2) \geq -2(x + 1)$

[e]  $6d + 1 \leq 5d - 3$

[f]  $6x + 2 \geq 14 + 5x$

[g]  $4n - 2(n - 1) \geq 0$

**5** Show by using examples that if  $a > b$ ,  $c > d$ , then it is not always correct that  $a - c > b - d$ .

**6** Put (✓) for the correct statement and (X) for the incorrect statement when a statement is false, give an example that shows why it is false, (given that  $x > y$ ).

[a]  $y < x$  ( )

[f]  $x + y > y$  ( )

[b]  $x > 0$  ( )

[g]  $y^2 > x$  ( )

[c]  $y^2 > 0$  ( )

[h]  $y^2 < xy$  ( )

[d]  $y^2 > y$  ( )

[i]  $xy < x^2$  ( )

[e]  $xy > 0$  ( )

[j]  $x^3 < y^2$  ( )

## Miscellaneous Exercises

### 1 Circle the correct value:

[a] What is the best estimated value for the fraction  $\frac{1}{6}$ ? [ 15%, 17%, 20%, 25% ]

[b] If the total weight of 500 grains of salt is  $6\frac{1}{2}$  gm, then the weight of one grain equals ..... gm. [  $\frac{78}{10000}$ ,  $\frac{13}{1000}$ ,  $\frac{78}{1000}$ ,  $\frac{325}{1000}$  ]

[c] What is the best estimated value for the rational number  $x$  on the number line?

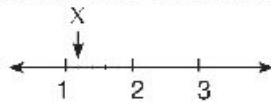

[  $1\frac{1}{10}$ ,  $1\frac{2}{10}$ ,  $1\frac{5}{10}$ ,  $1\frac{6}{10}$  ]

[d] If the thickness of a sheet of paper is 0.012 cm, Then a ream of 400 sheets is of height ..... [  $48 \times 10^8$ ,  $48 \times 10^2$ ,  $4.8 \times 10^0$ , 48 ]

[e]  $\sqrt{10^2 - 6^2} = \dots\dots\dots$  [ 4, 8,  $\pm 4$ ,  $\pm 8$  ]

[f] Quarter of  $4^{20} = \dots\dots\dots$  [  $4^5$ ,  $4^{10}$ ,  $4^{19}$ ,  $2^{10}$  ]

### 2 [a] Which is greater $(-2)^{62}$ or $(-2)^{63}$ ?

[b] Shade the region that represents  $(\frac{1}{3})^2 \times \frac{1}{2}$  of the figure below:



### 3 [a] Is the number $10^{25} - 7$ divisible by 3? Why?

[b] If  $x = 3$ , What is the numerical value of the expression:  $2(\frac{5x+3}{4x-3})$ ?

### 4 [a] Rectangle its length twice of its width, if its perimeter 36 cm Find each of its length and its width.

[b] The area of a square equals the area of a triangle whose base 9cm, height 8cm, Calculate the length of the square.

# UNIT TEST

Answer all the following questions

## 1 Choose the correct answer:

[a]  $\frac{6a^2x^4}{2a^3x^3} = \dots\dots\dots$  [  $3ax$ ,  $3a^3x^7$ ,  $\frac{3x}{a}$ ,  $\frac{3}{ax}$  ]

[b]  $\frac{(-2s^2t)^5}{(-4st^2)^2} = \dots\dots\dots$  [  $-\frac{s^3}{2t}$ ,  $-\frac{s^4}{2t}$ ,  $\frac{s^5}{2t^2}$ ,  $\frac{s^4}{t}$  ]

[c] Which of the following numbers is the greatest? [  $6.3 \times 10^5$ ,  $9.8 \times 10^4$ ,  $5.2 \times 10^3$  ]

[d]  $\left(\frac{m^2}{n^3}\right)^{-1} \left(\frac{3m^{-2}}{n^2}\right)^{-2} = \dots\dots\dots$  [  $\frac{9m^2}{n^7}$ ,  $\frac{m^2}{9n^7}$ ,  $\frac{m^2}{9n}$ ,  $\frac{9m^6}{n}$  ]

[e]  $\frac{(2ab^{-2})^0}{3^0a^2b} = \dots\dots\dots$  [  $\frac{a^5}{3b^3}$ ,  $a^2$ ,  $1$ ,  $\frac{a^2}{b}$  ]

[f]  $2.37 \times 10^{-4} = \dots\dots\dots$  [  $0.00237$ ,  $0.000237$ ,  $23700$ ,  $0.0000237$  ]

## 2 [a] put each of the following in the simplest form:

1)  $\left(\frac{s^2t}{s}\right)\left(\frac{t^2}{2s}\right)^3$

2)  $\left(\frac{a^{-1}}{b^2}\right)\left(\frac{a^{-1}}{2b^2}\right)^{-2}$

[b] Put the suitable sign (< or >):

1)  $6.4 \times 10^3$    $4.6 \times 10^3$

5)  $2.10 \times 10^{-5}$    $1.82 \times 10^{-5}$

2)  $6.2 \times 10^1$    $4.1 \times 10^5$

6)  $9.1 \times 10^{-1}$    $1.2 \times 10^{-5}$

3)  $0.0041$    $3.2 \times 10^{-2}$

7)  $6.920 \times 10^5$    $96230$

4)  $4370$    $3.41 \times 10^4$

8)  $3.69 \times 10^4$    $0.0000623$

### 3 Complete:

[a] The additive inverse of  $(\frac{-2}{5})^2$  is .....

[b] The multiplicative inverse of  $\sqrt{\frac{10}{2.5}}$  is .....

[c]  $(\frac{-3}{7})^7 \div (\frac{3}{7})^5 = \dots\dots\dots$  in its simplest form

[d] The solution set of the equation  $-2x + 1 = -3$  in  $Z$  is .....

[e]  $(\frac{-1}{2})^3 - (-\frac{1}{2})^2 = \dots\dots\dots$

[f]  $\sqrt{(\frac{-5}{6})^2} = \dots\dots\dots$

### 4 [a] The length of a rectangle is twice its width and its surface area is $24.5 \text{ cm}^2$ ,

calculate each of its length and width.

[b] If  $\frac{3}{4}$  of the area of a square is  $1\frac{11}{64} \text{ m}^2$ , calculate the side length of the square.

### 5 [a] If $\frac{m}{n}$ is a rational number, $\frac{m^2}{n^2} = 0.16$ . evaluate $(\frac{m}{n})^3$

[b] If  $a = -\frac{1}{2}$ ,  $b = 2$ , and  $c = \frac{3}{4}$ , then find the numerical value of  $a^3b^2 + b^2c - 8abc$ .

### 6 [a] Solve the equation: $\frac{5}{6}x - 4 = 11$ , $x \in Q$

[b] Evaluate:  $16x \div 4y + 4yx$  for  $x = 9$ , and  $y = 6$

[c] If the substitution set is  $\{2, 4, 6, 8, 10\}$ , find the solution set of the inequality:

$$x^3 - 7 > 6$$

### 7 [a] Solve the inequality and represent the solution set on the number line:

1)  $9x + 1 \leq 4(2x + \frac{1}{4})$ ,  $x \in Z$

2)  $1 - (4a - 1) > 2(a - 3)$ ,  $a \in Q$

[b] The price of one kilogram of bananas exceeds the price of one kilogram of grapes by one pound. If the price of 2 kg of bananas and 4 kg of grapes is 20 pounds, find the price of one kilogram for both bananas and grapes.



**Pierre - Simon, marquis de Laplace**  
**1749-1827**

Laplace (March 23, 1749 - March 5, 1827) was a french mathematician and astronomer. His first work was published in 1771 started with differential equations however was already starting to think about the mathematical and philosophical concepts of probability and statistics.

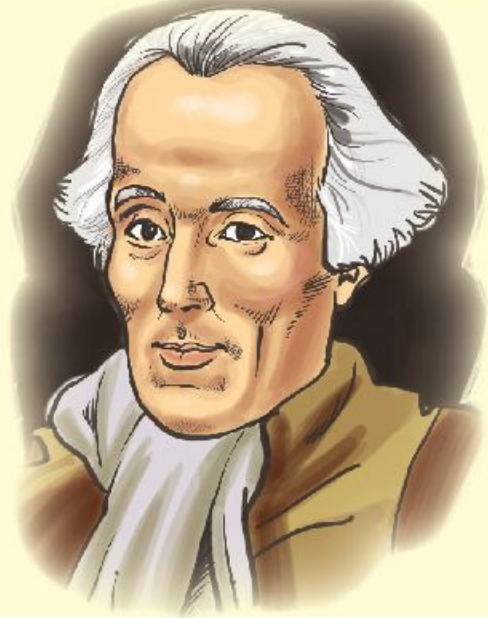
**CONTENTS**

## Lesson 1: Samples

Systematic sample

Random sample

## Lesson 2: probability

Experimental probability

Theoretical probability

Activity

Unit test

### Systematic sample

A sample is a small part of a population. 'Population' means a collection, set or group of objects being studied and is selected randomly.

Samples are used for facilitating collecting information about population, it's more close to the reality, and decisions can be taken in its light and generalizing them on the whole population.

#### How to choose systematic sample :

To select a systematic sample from society it must be distributed randomly.

It will not give a fairly representation from the talented pupils of a class in a school, because the sample does not represent all pupils the following figure shows the selection of a 10% sample by selecting every tenth item or individual.

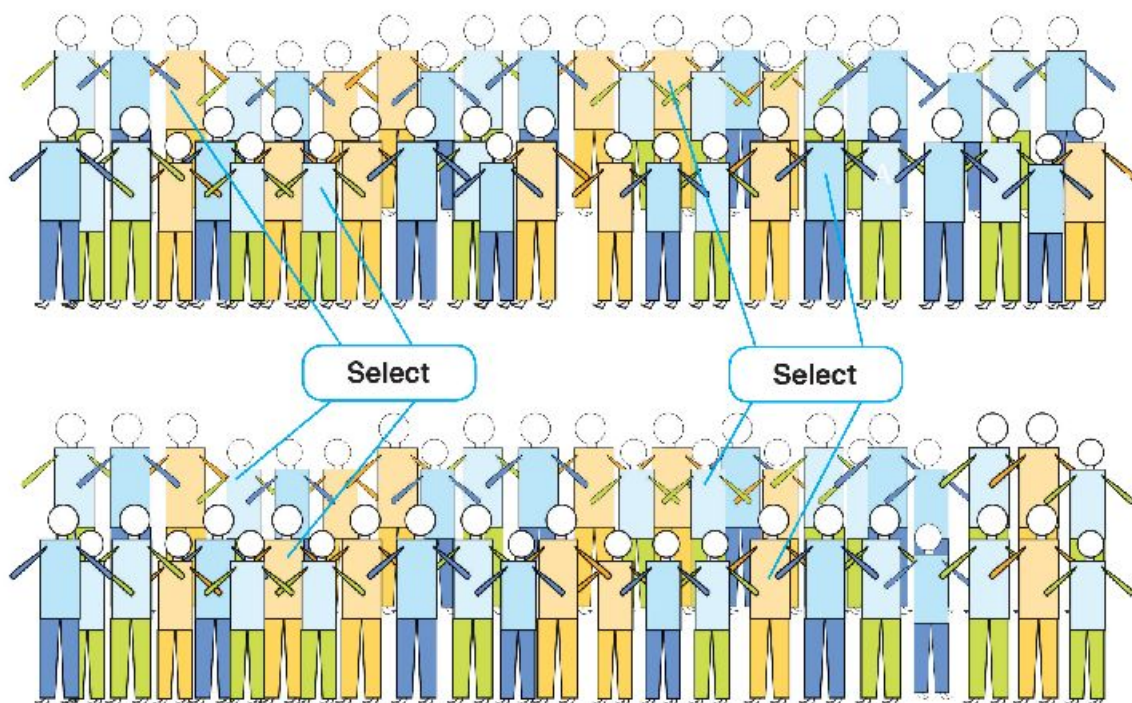

#### Drill:

- [a] How would your class be arranged to get a random sample by systematic sample?  
Would all the boys be together and girls together?
- [b] Is the number of pupils enough to get a random sample? .....
- [c] If the number of pupils in a school is 600, how many pupils could be selected by 12% to get a systematic sample? .....

## Random sample

In random sample every member of a population must have an equal chance of being selected. Members for random sampling can be selected by:

- Giving every member of the population a number;
- Using the random number function on your calculator.

**Suppose** 212 mechanics worked in vehicle maintenance and testing for a nation-wide car hire company. The company wants to know their point of view on:

- Avoiding workshop delays due to non-availability of spare parts;
- Increasing vehicle reliability per 1000 km usage;
- Increasing quality control through non-workshop spot checks.

Suppose we want to produce random numbers in the range 0 to 212. A 10% Sample is considered adequate to provide reliable information and so 21 random Numbers are required.

A scientific calculator's programme will generate random numbers in the range 0.000 to 0.999. This gives an effective sample range from 0 to 999.

For numbers from 0 to 212 the random numbers above 0.212 are ignored. The generation of random numbers must continue until 10% of 212 items are identified, that is 21 random numbers. The exact procedure is shown in the 'Activity' section after the 'Lessons' section of this unit.

Suppose the computer programme generated these random numbers using:

SHIFT RAN # = for each number

194	3	178	87	55	133	16	117	32	172
156	177	195	48	154	94	138	58	193	76
205									

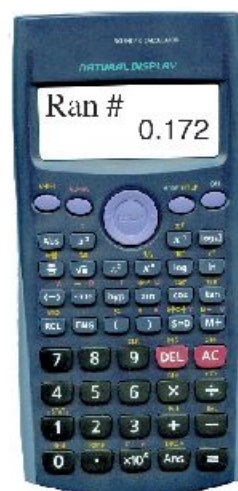

The 21 mechanics which were allocated these numbers would then be the sample for the survey.

Random numbers can also be generated using 'Excel's' "Randomize" function. This will also be described in the 'Activity' section of this unit.

### Exercise (2-1)

- 1** A factory's canteen service wanted to find the preferences of their 427 employees during their 15 minute break. Each employee was allocated a number from 1 to 427. A 10% sample of the 427 were to be surveyed and asked to select a preference from:

- Hot beverage;
- Hot soup with bread;
- Cold drink with biscuits;
- Fruit with sparkling water.

The sample were determined by selecting 43 sample numbers in the range using a calculator programme.

Identify the sample numbers using a calculator.

- 2** A sports survey was to be carried out among 318 school-age students in a district to help decide on the type of recreational services which would serve 'community youth' needs.

Each school-age student was allocated a number from 1 to 318.

A 10% sample of the 318 were to be surveyed and asked to select a preference from:

- Outdoor team games;
- Individual competition;
- Indoor games.

Determine the sample by selecting 31 sample numbers using Excel programme, described in the activity.

- 3** A construction company wanted to ask their 362 Workers about 'on site' safety in terms of:

- Work position safety access;
- Scaffold erection and maintenance;
- Guard and toe-rail positioning.

They asked 12% (to the nearest whole number) of their workforce with employment numbers from 20 to 382 to give their opinions.

The employment numbers of the 12% were identified by using a computer programme. Use a computer programme to identify target employment numbers for the survey.

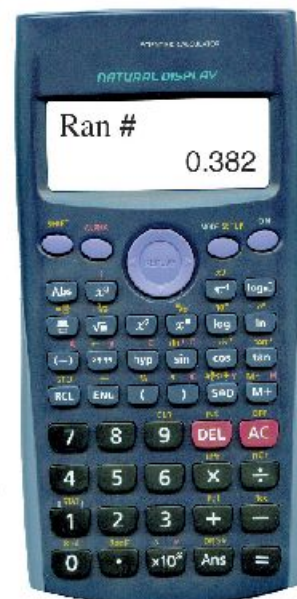



## Lesson 2

## Probability

## Experimental probability

The tossing, throwing and spinning activities are **trials** or **events**.

The results of an experiment are called "occurrences" or "**outcomes**".

For any particular outcome of any event:

$$\text{Experimental probability} = \frac{\text{Number of trials in which the outcome occurs}}{\text{Total number of trials}}$$

## Coin tossing experiment



1. Toss a coin 30 times.
2. Record the 'heads' and 'tails' outcomes.
3. Draw a column "bar" graph for the data.
4. Write the ratio of the height of the 'heads' column "bar" to the heights of the 'tails' column "bar" as a fraction.
5. Deduce the probability of scoring 'heads' in 30 trials.

	Heads	Tails	Total
Tally			
frequency			30

## Die rolling experiment



1. Roll a die 60 times.
2. Record the outcomes.
3. Draw a column "bar" graph for the data.
4. Write the ratio of the number in the '1' column "bar" to the number in the '6' column "bar" as a fraction.
5. Deduce the probability of rolling a 5 in 60 trials.

	1	2	3	4	5	6	Total
Tally							
frequency							60

## Spinner experiment

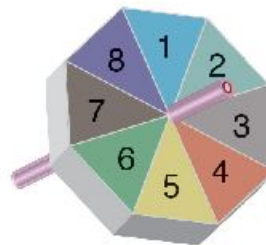

1. Spin a spinner 30 times.
2. Record the outcomes.
3. Draw a column "bar" graph for the data.
4. What is the probability of the Spinner coming to rest at '1'.

	1	2	3	4	5	6	7	8	Total
Tally									
frequency									30

## Exercise (2-2)

- 1** [a] Draw six parallel lines, 2 cm apart on a A4 sheet of paper.  
 [b] Cut a 2 cm stick from a matchstick.  
 [c] Slightly toss the stick in the air so that it falls from a suitable height onto the A4 sheet.  
 [d] Repeat the trial 50 times.  
 [e] Record the number of times the stick falls across the line and also between the lines.  
 [f] Deduce the probability of the stick falling between the lines.

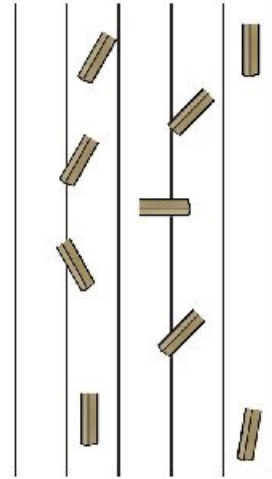

	Across	Between	Total
Tally			
frequency			50

$$P(\text{between lines}) = \frac{\text{Number of trials in which the outcome occurs}}{50} = \frac{\dots}{50} = \frac{\dots}{\dots}$$

- 2** [a] Drop a drawing pin 100 times from a suitable height.  
 [b] Record the number of times it lands with its point 'up' and its point 'down'.

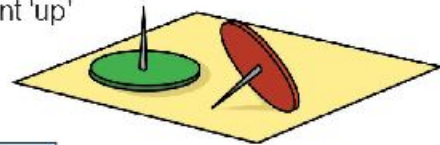

	'up'	'down'	Total
Tally			
frequency			100

- [c] Deduce the probability of the drawing pin landing point 'up' and point 'down'.

$$P(\text{'up'}) = \frac{\text{Number of trials in which the outcome occurs}}{100} = \frac{\dots}{\dots}$$

$$P(\text{'down'}) = \frac{\text{Number of trials in which the outcome occurs}}{100} = \frac{\dots}{\dots}$$

## Theoretical probability

Theoretical and experimental probability are closely related. As more and more experiments are performed the closer the experimental probability approaches the theoretical probability.

- For the coin-tossing experiment the possible outcomes are 'heads' or 'tails'. All the possible outcomes of an event make up the **sample space** or **possibility space**.

**For the coin experiment,**  
the sample space (S) is:

$$S = \{\text{Heads, Tails}\} \text{ or } S = \{H, T\}$$

The **sample space** is the set of all the possible outcomes of an experiment.

- For the die-rolling experiment,**

The set of all possible outcomes is  $\{1, 2, 3, 4, 5, 6\}$ .

So the sample space,  $S = \{1, 2, 3, 4, 5, 6\}$ .

Each outcome is an element of set S or a sub-set of S.



### Example 1

For a single toss of a coin, calculate the probability of E, heads.

**Solution:**

$$S = \{H, T\}, E = \{H\}$$

$$P(E) = \frac{n(E)}{n(S)} = \frac{1}{2} = 0.5$$

The probability of an outcome " $E \subset S$ " is written  $P(E)$ .

$$P(E) = \frac{\text{number of elements in } E}{\text{number of elements in } S}$$

$$P(E) = \frac{n(E)}{n(S)}$$

### Example 2

For one roll of a die, calculate the probability of:

[a]  $E_1$ , odd number

[b]  $E_2$ ,  $< 3$

[c]  $E_3$ ,  $= 7$

**Solution:**

$$E_1 = \{1, 3, 5\}, P(E_1) = \frac{n(E_1)}{n(S)} = \frac{3}{6} = \frac{1}{2} = 0.5$$

$$E_2 = \{1, 2\}, P(E_2) = \frac{n(E_2)}{n(S)} = \frac{2}{6} = \frac{1}{3} = 0.33 \text{ (2 decimal places)}$$

$$E_3 = \{\} = \phi, P(E_3) = \frac{n(E_3)}{n(S)} = \frac{0}{6} = 0 \text{ (impossible event)}$$

### Example 3

The set  $\{1, 2, 3, 4\}$  is used in writing a 2 - different digit number.

Find the probability of the following events:

A: The tens digit is even

B: Both of the two digits are even.

Tens	Units

**Solution :**

$$S = \{21, 31, 41, 12, 32, 42, 13, 23, 43, 14, 24, 34\},$$

$$n(S) = 12$$

$$A = \{21, 41, 42, 23, 43, 24\}, \quad P(A) = \frac{6}{12} = \frac{1}{2}$$

$$B = \{42, 24\}, \quad P(B) = \frac{2}{12} = \frac{1}{6}$$

### Example 4

A group of 100 students, 54 students have succeeded in English language, 69 students have succeeded in History and 35 students have succeeded in (both of them). One student is chosen at random from the group find the probability of the following events:

A is the event that he has succeeded in English language.

B is the event that he has succeeded in History.

C is the event that he has failed in History.

**Solution :**

$$P(A) = \frac{\text{number of succeeded students in English language}}{\text{number of all students in the group}} = \frac{54}{100}$$

$$P(B) = \frac{\text{number of succeeded students in history}}{\text{number of all students in the group}} = \frac{69}{100}$$

$$P(C) = \frac{\text{number of failed students in history}}{\text{number of all students in the group}} = \frac{100-69}{100} = \frac{31}{100}$$



## Exercise (2–3)

- 1 By accident, a coin is produced with two heads.

Complete:

- [a] Write the sample space for the tossed coin.

$$S = \{ \square \}, n(s) = \dots\dots$$

- [b] The probability that the tossed coin shows 'heads'

$$= P(E) = \frac{n(E)}{n(S)} = \frac{\dots}{\dots} = \square$$

- [c] The probability that the tossed coin shows 'tails'

$$= P(E) = \frac{n(E)}{n(S)} = \frac{\dots}{\dots} = \square$$

- 2 A fair die is rolled once. Calculate the probability of rolling:

- [a] an even number      [b] a prime number      [c] a number greater than 3

- 3 A card is drawn from a bag of 25 cards numbered from 1 to 25. Calculate the probability that the drawn card carries:

- [a] a number divisible by 5    [b] a number  $\geq 20$       [c] a perfect square number

- 4 A letter is selected at random from the word SCHOOL.

Calculate the probability of selecting the letter:

- [a] S      [b] O      [c] R

- 5 A cub is designed such that two opposite faces carry one of the digits 1, 2, 3, the cube is rolled and the apparent face is observed.

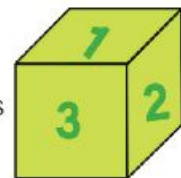

- [a] Write down the sample space.

- [b] What is the probability such that the number on the upper face is 2?

- [c] What is the probability such that the number on the upper face is odd?

- 6 A box contains 5 white, 4 black and 7 red balls. A ball is drawn randomly from the box. Calculate the probabilities of the following events:

- [a] The ball is white

- [b] The ball is red

- [c] The ball is not white

**7** One card is selected randomly from 8 cards numbered from 1 to 8. Write down the sample space, then find the probability of the following events:

- [a] getting an even number.
- [b] getting an odd number.
- [c] getting a number greater than or equal to 6.
- [d] getting a number divisible by 3.

**8** A die is rolled once and the number of dots on the upper face is observed, write down the sample space then find the probability of the following events:

- [a] getting a number greater than 6
- [b] getting a number satisfies the inequality:  $1 \leq X \leq 6$
- [c] getting a number satisfies the inequality:  $2 < X < 4$



**9** The set { 2, 3, 5 } is used in writing a 2-digit number. Find the probability of the following events:

- [a] The tens digit is odd.
- [b] The units digit is odd.
- [c] The sum of the two digits is 7.
- [d] The product of the two digits is 15.

**10** A class contains 40 students, 30 of them succeeded in Math, 24 succeeded in Science, and 20 succeeded in both.

A student is chosen at random, find the probability that this student is:

- [a] succeeded in math.
- [b] succeeded in science.
- [c] failed in science.
- [d] failed in both math and science.

**Activity of Unit (2): Statistics and Probability****Activity (1): The experimental Probability the theoretical Probability.**

The opposite graph Shows many of trials of the experiment of tossing a regular die many times.

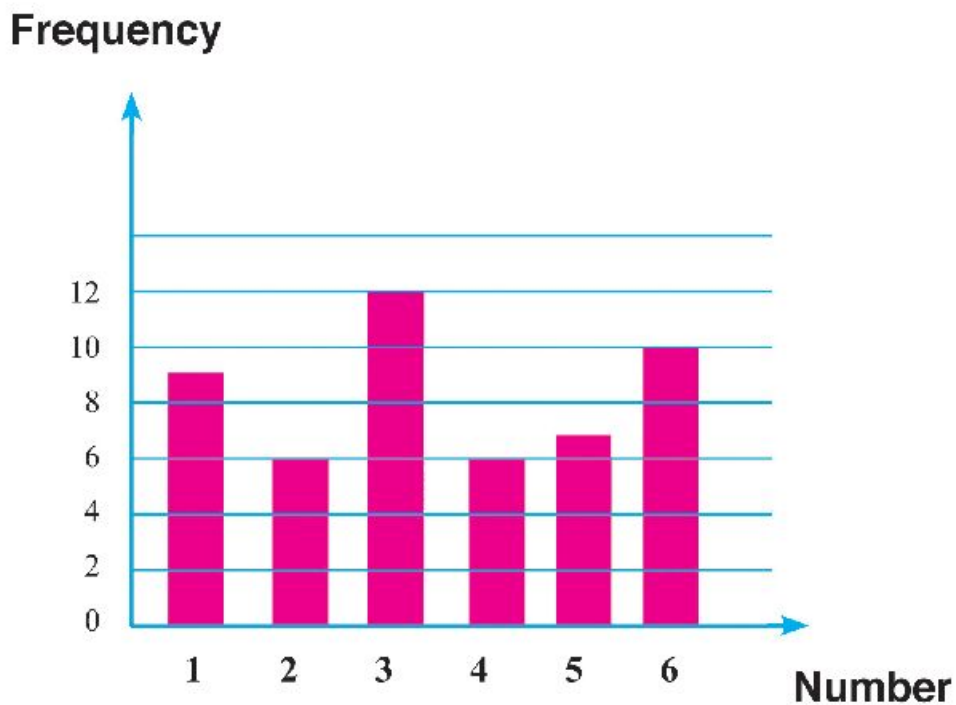

**a- Find the experimental probability for the appearance of the number 6.**

From the graph: we notice that:

The number 6 appears on the upper face 10 times.

also, from the graph the total number of trials for this experiment equals

$$6 + 9 + 12 + 6 + 7 + 10 = 50$$

$$\begin{aligned} P(6) &= \frac{\text{Number of outcomes you have got}}{\text{Number of all possible outcomes}} \\ &= \frac{10}{50} = \frac{1}{5} = 20\% \end{aligned}$$

**b- Calculate the theoretical probability for the appearance of the number 6.**

The sample space of this experiment =  $\{1,2,3,4,5,6\}$







$$P(6) = \frac{\text{Number of the elements of the event}}{\text{Number of the elements or the sample space}}$$
$$= \frac{1}{6} \approx 17\%$$

What do you explain the difference between the two answers of a , b ?

.....

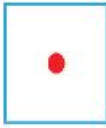
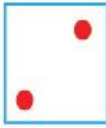
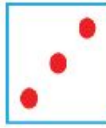
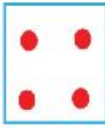
**Activity (2):** The following table shows the outcomes of tossing a regular die 120 times.

<b>Number</b>						
<b>Frequency</b>	16	24	17	25	30	8

- Calculate the experimental probability of getting a number that lies between 1 , 6.
- Calculate the theoretical probability of getting a number that lies between 1 , 6.
- What do you explain the difference between the two answers of a , b?

## Unit Test

**Tick for the correct answer:**

- 1** [a] Rashad is in a grade 7 class of 36 students. 16 of them are girls. If a student is selected at random from the class. What is the probability that the student is a boy?

$$\left[ \frac{4}{9} \square, \frac{1}{2} \square, \frac{5}{9} \square, \frac{1}{36} \square \right]$$

- [b] 48 people are employed by a small manufacturing company in 6 sections what is the probability that a worker, selected at random, works in 'stores'?

Sections	Management	Finance	Machinists	Stores	Packaging	Delivey
Employees	3	3	28	4	8	2

$$\left[ \frac{1}{48} \square, \frac{7}{12} \square, \frac{1}{16} \square, \frac{1}{12} \square \right]$$

- [c] 120 volunteers in three groups to make a design and report about environment cleanness:

if one of the volunteers selected at random?

group	Design	Production	Distribution
number	20	40	60

$$\left[ 0.5 \square, 0.3 \square, 0.4 \square, 0.1 \square \right]$$

- [d] A letter is selected at random from the name "ZAMALEK."

The probability of selecting the letter A is:

$$\left[ \frac{1}{7} \square, \frac{2}{7} \square, \frac{3}{7} \square, \frac{4}{7} \square \right]$$

- [e] A cubic die with numbers 1 to 6 is rolled once, The probability of rolling an even number is:

$$\left[ \frac{1}{3} \square, \frac{1}{6} \square, \frac{1}{4} \square, \frac{1}{2} \square \right]$$

**2** Hussen is in a Grade 7 class of 46 students. 19 of them are girls. If a student is selected at random from the class, what is the probability, (to 1 decimal place), that the student is:

- [a] a boy [b] a girl [c] Hussen?

**3** A card is chosen at random from ten cards numbered from 1 to 10, what is the probability that the selected card shows:

- [a] an odd number  
 [b] a prime number  
 [c] an even number  
 [d] an odd number greater than 3?

**4** A letter is chosen from the word ALEXANDRIA. What is the probability, as a decimal, that the letter will be:

- [a] R [b] X [c] A [d] P ?

**5** A sample consists of 100 persons who watch T.V, if someone was selected at random. What is the probability of that persons's preference?

Programs	Documentaries	Drama	News	Sport
Viewers	12	31	21	36

- [a] sport [b] news [c] drama [d] documentaries

**6** The following data illustrate a various kinds of food for 250 persons who have dinner in a restaurant if someone is selected at random. What is the probability of having a sandwich?

Food	Cheese Sandwich	Kushary	Fool & Taameya Sandwich	Liver Sandwich
Number of persons	10	100	90	50

- [a] Fool & Taameya Sandwich [c] Liver Sandwich  
 [b] Kushary [d] Cheese Sandwich

**Euclid****(325 - 265BC)**

Euclid introduced the system of axioms and collated his work in geometry in a book entitled "Alosoul" since that time, geometry of Euclid was considered a model of logical proof.

Common notations:

- Things which are equal to one thing are equal to each other.
- If equals are added to equals, then the sums are equal.
- Things which coincide with one another are equal to each other.
- The whole is greater than the part.

**CONTENTS**

- lesson 1 Deductive proof
- lesson 2 The polygon
- lesson 3 The triangle
- lesson 4 Pythagoras theorem
- lesson 5 Geometric transformations
- lesson 6 Reflection
- lesson 7 Translation
- lesson 8 Rotation
- Activity unit
- Test unit

You have realized several geometrical properties by experimentation.

You can use some of these properties to derive other geometrical properties using a deductive proof.

This activity will give you the opportunity to practice your deductive proof skills.

### Theorem (1)

**If two straight lines intersect, then the measure of each two vertically opposite angles are equal in measure.**

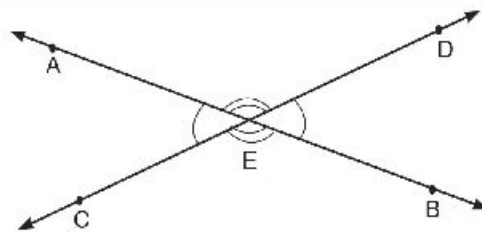

**Given:** The two straight lines AB and CD intersect at E.

**Required to proof (R . T . P .):**  $m(\angle AED) = m(\angle BEC)$

**Proof:**

$\therefore \angle AEC$  and  $\angle AED$  are adjacent angles where  $\overrightarrow{EC} \cup \overrightarrow{ED} = \overrightarrow{CD}$

$\therefore m(\angle AEC) + m(\angle AED) = 180^\circ$

$\therefore \angle AEC$  and  $\angle BEC$  are adjacent angles where  $\overrightarrow{EA} \cup \overrightarrow{EB} = \overrightarrow{AB}$

$\therefore m(\angle AEC) + m(\angle BEC) = 180^\circ$

$\therefore m(\angle AEC) + m(\angle AED) = m(\angle AEC) + m(\angle BEC)$

$\therefore m(\angle AED) = m(\angle BEC)$  (Q . E . D .)

Show that :  $m(\angle AEC) = m(\angle BED)$

## Theorem (2)

The sum of the measures of the accumulative angles at a point is equal to  $360^\circ$

**Given:**  $\vec{OA}$ ,  $\vec{OB}$ ,  $\vec{OC}$ , and  $\vec{OD}$

are rays that start at O,

**R . T . P . :** prove that the sum of the measures of the accumulative angles at the point O is  $360^\circ$ .

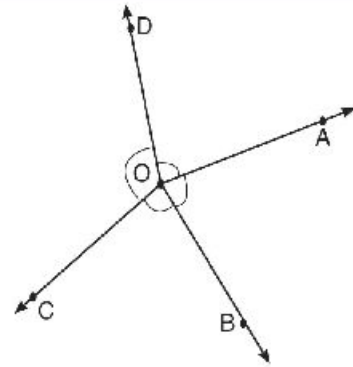

**Construction:** Draw the straight line  $\overleftrightarrow{DO}$

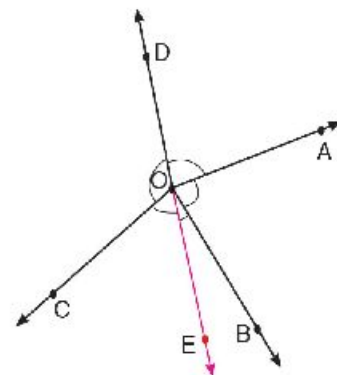

**Proof:**  $\therefore m(\angle EOB) + m(\angle BOA) + m(\angle AOD) = 180^\circ$

$$m(\angle EOC) + m(\angle \dots) = 180^\circ$$

$$\therefore m(\angle EOB) + m(\angle BOA) + m(\angle AOD) + m(\angle EOC) + m(\angle \dots)$$

$$= 180^\circ + \dots^\circ = \dots^\circ$$

$$\therefore m(\angle AOB) + m(\angle BOC) + m(\angle COD) + m(\angle DOA) = \dots^\circ$$

Q . E . D .

### Example 1

In the figure opposite:

$\longleftrightarrow$   $\longleftrightarrow$   
 $EF$  intersect  $AB, CD$  at  $X, Y$

respectively,  $m(\angle AXE) = m(\angle DYF) = 75^\circ$

$\longleftrightarrow$   $\longleftrightarrow$   
**Prove that:**  $AB \parallel CD$

**Solution**

**Given:**  $m(\angle AXE) = m(\angle DYF) = 75^\circ$

$\longleftrightarrow$   $\longleftrightarrow$   
**R . T . P.:**  $AB \parallel CD$

**Proof:**  $\because m(\angle BXY) = m(\angle AXE) = 75^\circ$  vertically opposite angles,

$m(\angle DYF) = 75^\circ$

$\therefore m(\angle BXY) = m(\angle DYF)$

$\because \angle BXY, \angle DYF$  are equal in measure and corresponding

$\longleftrightarrow$   $\longleftrightarrow$   
 $\therefore AB \parallel CD$

Q . E . D .

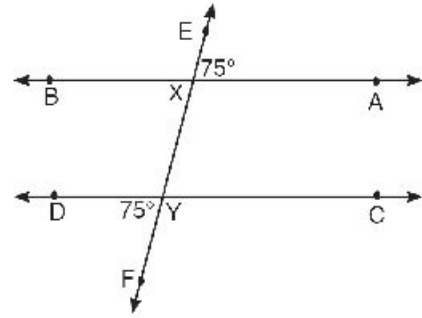

### Example 2

In the figure opposite:

$\overrightarrow{DC} \parallel \overrightarrow{AB}, E \in AB$

$m(\angle CBE) = 53^\circ, m(\angle D) = 127^\circ$

**Prove that:**  $\overline{AD} \parallel \overline{BC}$

**Solution**

**Given:**  $\overrightarrow{DC} \parallel \overrightarrow{AB}, m(\angle CBE) = 53^\circ,$

$m(\angle D) = 127^\circ$

**R . T . P.:**  $\overline{AD} \parallel \overline{BC}$

**Proof:**  $\because \overrightarrow{DC} \parallel \overrightarrow{AB}, \overline{AD}$  is a transversal

$\therefore m(\angle A) + m(\angle D) = 180^\circ$  interior angles in one side of the transversal

$\therefore m(\angle A) = 180^\circ - 127^\circ = 53^\circ$

$\because \angle A, \angle CBE$  are equal in measure and corresponding

$\therefore \overline{AD} \parallel \overline{BC}$

Q . E . D .

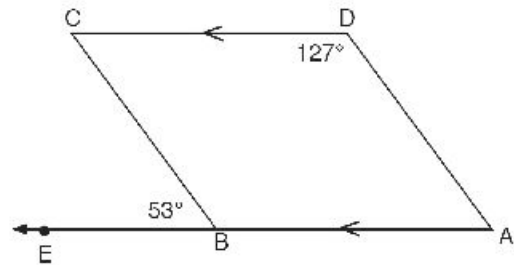



**Exercise 3-1**

**1** In the figure opposite, prove that:

[a] If  $AB \parallel CD$ , then  $m(\angle XEA) = m(\angle EFC)$ .

[b] If  $AB \parallel CD$ , Then  $m(\angle EFC) + m(\angle AEF) = 180^\circ$

[c] If  $m(\angle XEA) = m(\angle EFC)$ , then  $AB \parallel CD$ .

[d] If  $m(\angle EFC) + m(\angle AEF) = 180^\circ$ , then  $AB \parallel CD$

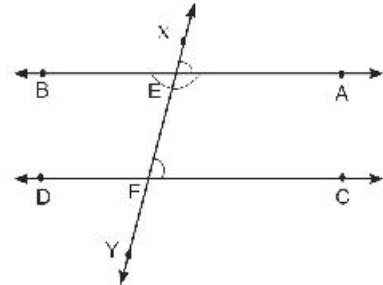

**2** Prove that: [a] A straight line which is perpendicular to one of two parallel lines is also perpendicular to the other.

[b] A straight line that is parallel to one of two parallel lines is also parallel to the other.

**3** In the figure opposite, prove that:

$m(\angle DXE) = 85^\circ$

Then calculate  $m(\angle DXC)$  and  $m(\angle EXF)$ .

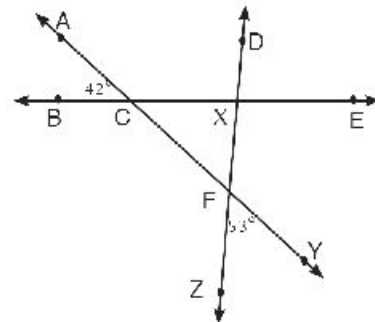

**4** In the figure opposite:

ABC is a triangle,  $m(\angle B) = m(\angle C)$  and AD is the bisector of  $\angle A$ .

prove that :  $AB = AC$

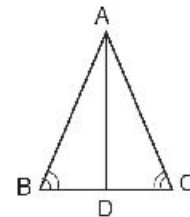

**5** In the figure opposite:

$EC = DB$  and DXYE is a rectangle.

prove that:  $m(\angle ADE) = m(\angle AED)$ .

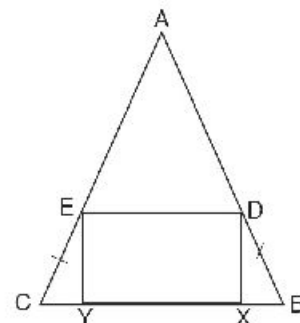

**6 In the figure opposite:**

$AD = CD$  and  $AB = CB$ .

Use the properties of congruent triangles to show that

[a]  $BD$  bisects  $\angle ADC$

[b]  $\overline{AC}$  and  $\overline{DB}$  are perpendicular to each other.

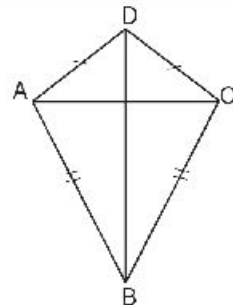

**7** A rectangle is a special case of a parallelogram with four right angles. Use the properties of congruent triangles to show that its diagonals are equal in length.

**8 In the figure opposite:**

[a] Is  $\triangle ADE$  congruent to  $\triangle CBF$ ?

Give your reason (s).

[b] prove that:

1)  $\triangle DEF \cong \triangle BFE$

2)  $\triangle ABE \cong \triangle CDF$

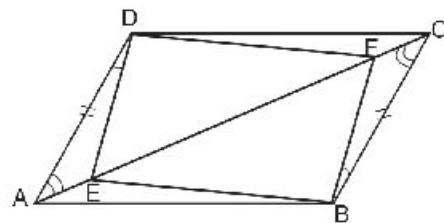

**9 In the figure opposite:**

[a] Is  $\triangle PAQ$  congruent to  $\triangle QBO$ ?

Give your reason (s).

[b] Show that:

1)  $\triangle PQR \cong \triangle ORQ$

2)  $\triangle PDR \cong \triangle RCO$

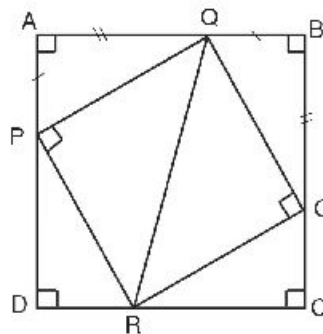

**10 In the figure opposite:**

$AD = AE$ ,  $m(\angle ADC) = m(\angle AEB)$

Show that:

[a]  $BE = CD$

[b]  $BD = CE$

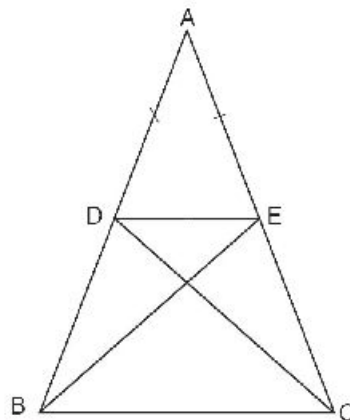

## Lesson 2

## The polygon

Each one of the following figures is a simple closed line formed from the union of line segments.

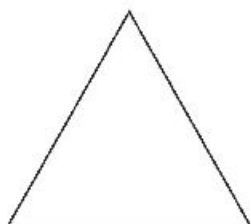

Triangle  
(3 sides)

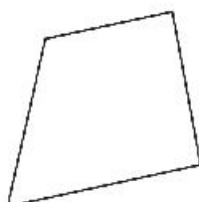

Quadrilateral  
(4 sides)

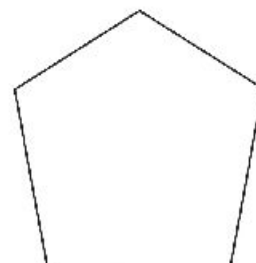

Pentagon  
(5 sides)

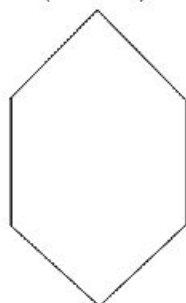

Hexagon  
(6 sides)

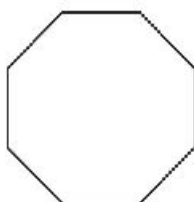

Octagon  
(8 sides)

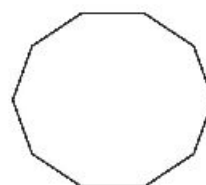

Decagon  
(10 sides)

**Polygons are plane figures with three or more sides.**

### The convex polygon

In the convex polygon, any straight line determined by two consecutive vertices, the remaining vertices are on one side of this line.

### The concave polygon

In the concave polygon, there are straight lines determined by two consecutive vertices, the remaining vertices are on the two sides of these lines.

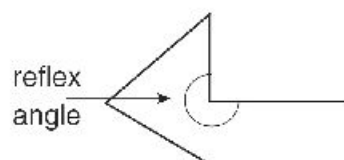
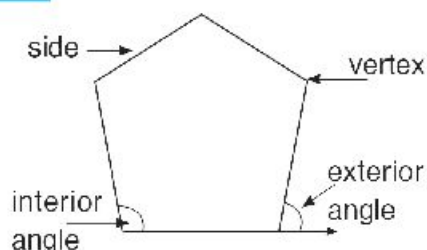

**1** In each polygon, diagonals are drawn from any vertex, complete

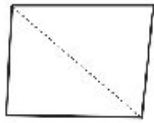

The sum of the interior angles is

$$2 \times 180^\circ = 360^\circ$$

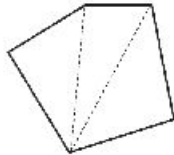

The sum of the interior angles is

$$3 \times \dots\dots\dots = \dots\dots\dots^\circ$$

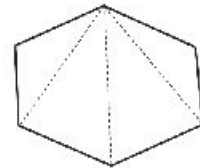

The sum of the interior angles is

$$4 \times \dots\dots\dots = \dots\dots\dots^\circ$$

**2** Complete the table:

Name of the polygon	Number of sides	Number of triangles	Sum of measures of interior angles
Quadrilateral	4	2	$2 \times 180^\circ = 360^\circ$
Pentagon	5		
Hexagon	6		
Heptagon	7		
Octagon	8		
Nonagon	9		
Decagon	10		
n-gon	n		

At each vertex of any polygon, the sum of the measures of the interior and the exterior angles is  $180^\circ$

**Example:**

For a hexagon, the sum of the measures of six interior and six exterior angles is  $6 \times 180^\circ$ , while the sum of the measures of the interior angles is  $4 \times 180^\circ$ , so the sum of the measures of the exterior angles is  $2 \times 180^\circ = 360^\circ$

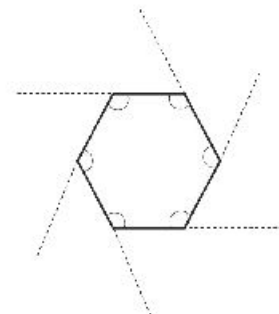

The sum of the measures of the interior angles of an  $n$ -sided convex polygon is  $(n - 2) \times 180^\circ$

The sum of the measures of the exterior angles of an  $n$ -sided convex polygon is  $360^\circ$

The measure of the interior angle of a convex regular polygon of  $n$  sides is  $\frac{(n - 2) \times 180^\circ}{n}$

### Example 1

How many sides has a regular polygon, if its interior angles are  $120^\circ$  each?

#### Solution

$\therefore$  The sum of the measures of the interior angles of an  $n$ -sided polygon is  $(n - 2) \times 180^\circ$

$\therefore$  The measure of each interior angle of an  $n$ -sided regular polygon is  $\frac{(n - 2) \times 180^\circ}{n}$

$$\therefore \frac{(n - 2) \times 180^\circ}{n} = 120^\circ.$$

$$180n - 360 = 120n$$

$$60n = 360$$

$$\therefore n = 6$$

#### Another solution

The measure of each exterior angle =  $180^\circ$  – the measure of the interior angle

$$= 180^\circ - 120^\circ$$

$$= 60^\circ$$

But the sum of the measures of the exterior angles =  $360^\circ$

$$\therefore \text{the number of sides} = \frac{360^\circ}{60^\circ} = 6$$

### Example 2

The ratio between the measures of the angles of a quadrilateral is 2: 2: 3: 5.

Calculate the measure of the largest angle.

#### Solution

The sum of the measures of interior angles =  $(4 - 2) \times 180^\circ$

$$= 360^\circ$$

The measure of the Largest angle =  $\frac{5}{2 + 2 + 3 + 5} \times 360^\circ = 150^\circ$

**Parallelogram:**

A parallelogram is a quadrilateral, in which each two opposite sides are parallel.

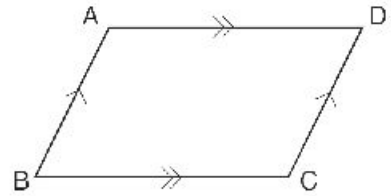

**Properties of a parallelogram:**

1. Each two opposite angles of a parallelogram are equal in measure.
2. Each two opposite sides of a parallelogram are equal in length.
3. The diagonals of a parallelogram bisect each other.
4. The sum of measures of each two consecutive angles in a parallelogram is  $180^\circ$ .

**Notice**

A quadrilateral in which only two opposite sides are parallel is called a trapezium.

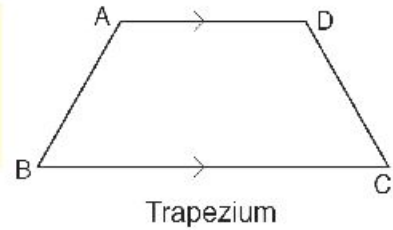

**Drill**

Draw the quadrilateral ABCD in each of the following cases:

- 1)  $\overline{AB} \parallel \overline{DC}$  ,  $\overline{AD} \parallel \overline{BC}$
- 2)  $\overline{AB} \parallel \overline{DC}$  ,  $AB = DC$
- 3)  $AB = DC$  ,  $AD = BC$
- 4)  $m(\angle A) = m(\angle C)$  ,  $m(\angle B) = m(\angle D)$
- 5)  $\overline{AC}$  and  $\overline{BD}$  bisect each other

\* From the previous, deduce the cases in which the quadrilateral is a parallelogram.

## Special cases of a parallelogram

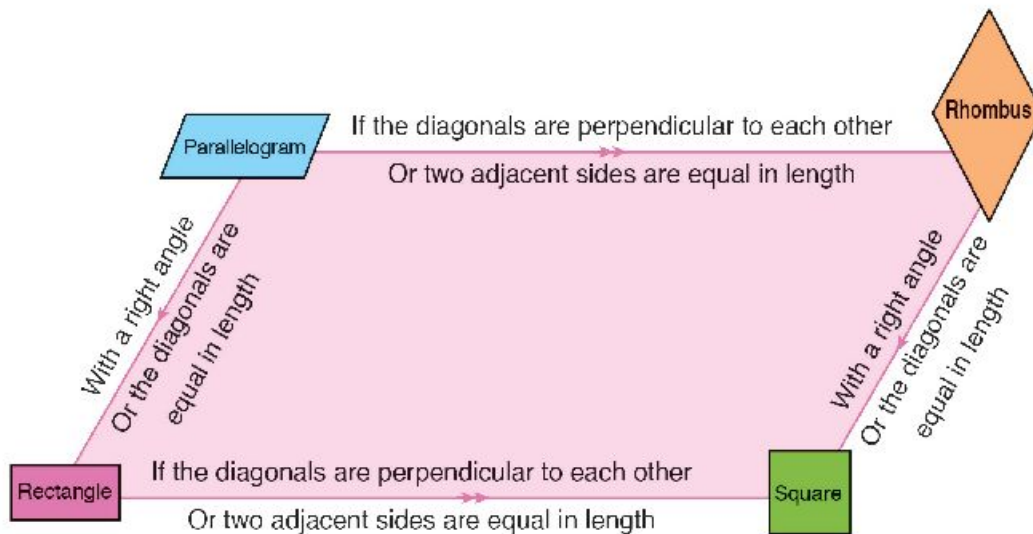

## Drill

## Complete:

- 1) A square is a ..... with a right angle
- 2) The quadrilateral in which all sides are equal in length is called .....
- 3) The parallelogram in which diagonals are ..... is called a rectangle.
- 4) The parallelogram in which diagonals are perpendicular is called ..... or .....
- 5) ABCD is a parallelogram in which  $m(\angle A) = 50^\circ$ , then  $m(\angle B) = \dots^\circ$
- 6) A rectangle is a ..... with a right angle
- 7) The quadrilateral in which diagonals bisect each other is called .....
- 8) If ABCD is a rhombus, then .....  $\perp$  .....
- 9) The quadrilateral in which two opposite sides are parallel is called .....
- 10) In the parallelogram XYZL, if  $m(\angle X) = \frac{1}{2} m(\angle Y)$  then  $m(\angle Y) = \dots^\circ$
- 11) Each of the two diagonals of the ..... makes an angle of measure  $45^\circ$  with the adjacent side.
- 12) The side length of a rhombus whose perimeter 42 cm equals ..... cm.

### Exercise 3-2

**1** Calculate the measure of the unknown angle, giving reasons for your answers:

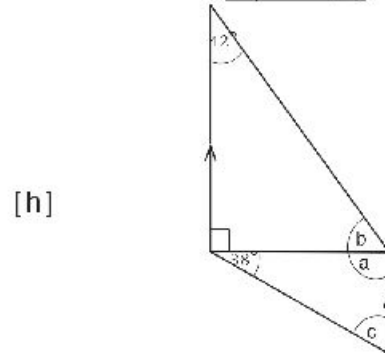
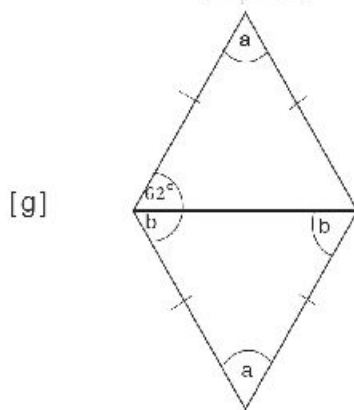
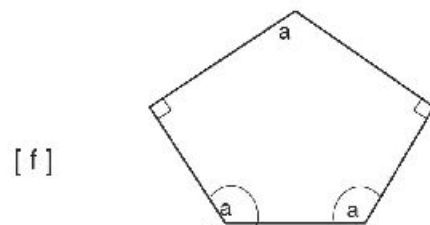
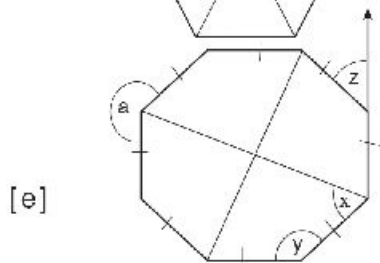
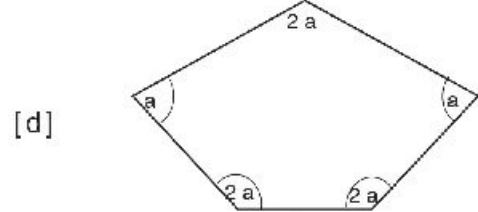
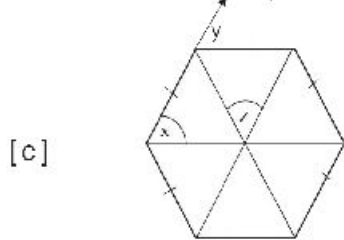
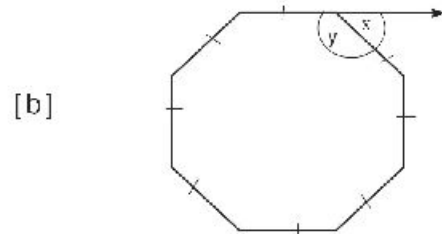
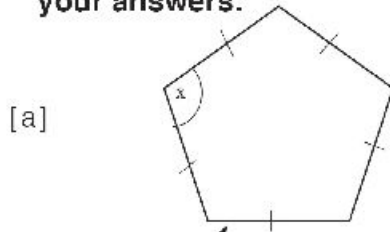

**2** Calculate the number of sides of a regular polygon, if the measure of each interior angle is:

[a]  $140^\circ$

[b]  $135^\circ$

**3** Is it possible that a regular polygon have an interior angle of measure  $100^\circ$  ? Why?

**4** If the measure of the exterior angle of a regular polygon is  $30^\circ$ , How many sides does it have? What is the sum of the measures of its interior angles?



**5** In the figure opposite,

$$\overline{AB} \parallel \overline{DC} \quad , \quad \overline{AC} \cap \overline{BD} = \{M\}$$

$$m(\angle DAC) = 30^\circ \quad , \quad m(\angle DBC) = 40^\circ$$

$$\text{and } m(\angle AMB) = 70^\circ$$

Prove that: ABCD is a parallelogram

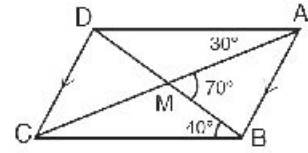

**6** In the figure opposite,

ABCD is a square,  $E \in \overrightarrow{BC}$  and  $\overline{AC} \parallel \overline{DE}$

1) Prove that: ACED is a parallelogram

2) Find  $m(\angle ACE)$

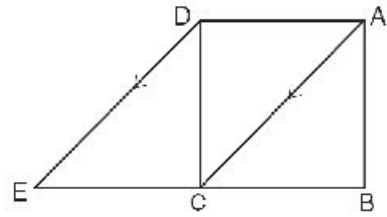

**7** In the figure opposite, ABCD is a rhombus, in which,

$\overline{BD}$  is a diagonal and

$$m(\angle ABD) = 62^\circ.$$

Find with proof  $m(\angle A)$

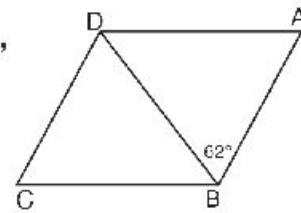

**8** In the figure opposite,  $E \in \overline{BC}$ ,  $m(\angle BAE) = 45^\circ$ ,

$$m(\angle AEB) = 70^\circ \quad , \quad m(\angle D) = 65^\circ$$

$$\text{and } m(\angle C) = 115^\circ.$$

Prove that: ABCD is a parallelogram

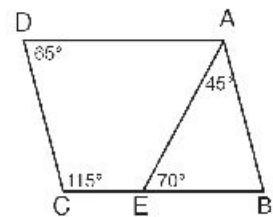

## Miscellaneous Exercises

**1** In each of the following figures, if  $\vec{AD} \parallel \vec{BC}$ , Find  $m(\angle ABC)$ , giving reason.

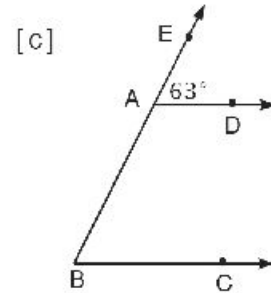
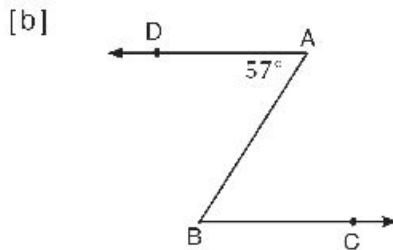
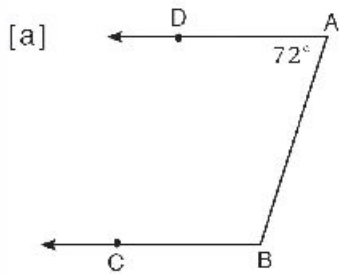

**2** In each of the following figures, if  $MN$  intersect  $AB, CD$  at  $E$  and  $F$  respectively.

Prove that:  $AB \parallel CD$

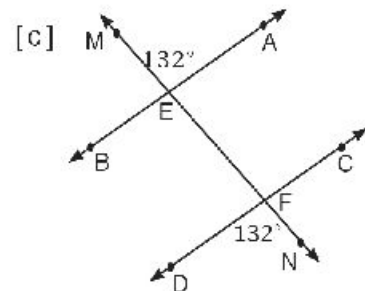
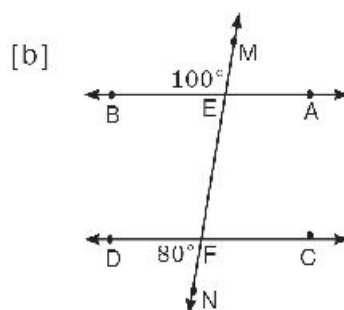
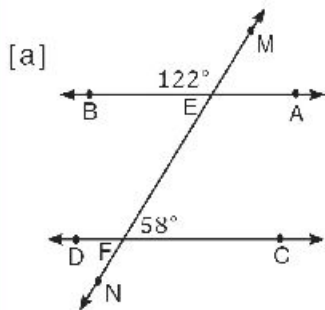

**3** In the figure opposite:

$$\vec{AC} \cap \vec{DE} = \{B\},$$

$$m(\angle ABD) = 40^\circ, \text{ and}$$

$\vec{BE}$  bisects  $\angle CBF$

find  $m(\angle ABF)$

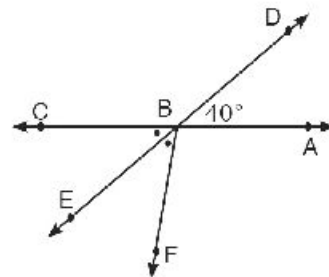

**4** In the figure opposite:

$B \in \overleftrightarrow{AC}$ ,  $m(\angle CBE) = 116^\circ$ , and

$\overrightarrow{BD}$  bisects  $\angle ABE$

find  $m(\angle ABD)$

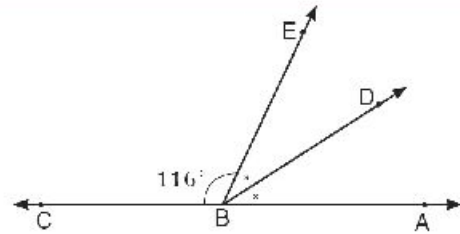

**5** In the figure opposite:

$\overleftrightarrow{CE} \cap \overleftrightarrow{FD} = \{B\}$ ,

$m(\angle ABC) = 40^\circ$ , and

$m(\angle ABF) = 30^\circ$ ,

find  $m(\angle DBC)$

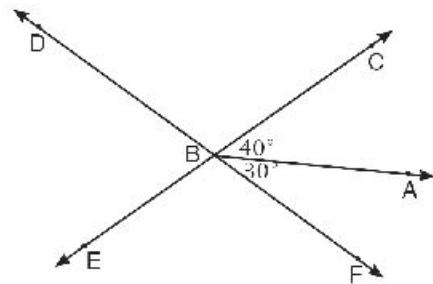

**6** In the figure opposite:

$m(\angle ABC) = 110^\circ$ ,  $m(\angle CBD) = 35^\circ$ ,

and  $m(\angle ABE) = 140^\circ$

find  $m(\angle EBD)$

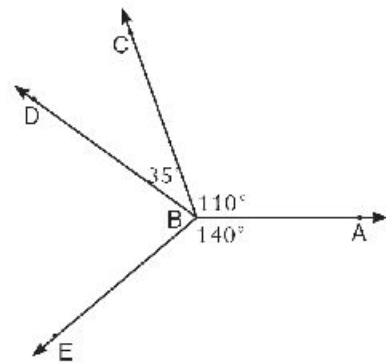

**7** In the figure opposite:

$\overleftrightarrow{AB} \parallel \overleftrightarrow{CD}$ ,  $m(\angle A) = 50^\circ$ ,

$\angle ACE$  is right, and  $m(\angle E) = 40^\circ$

Prove that:  $\overleftrightarrow{AB} \parallel \overleftrightarrow{EF}$

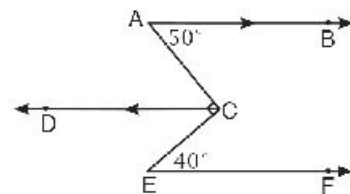

**8** In the figure opposite:

$\overrightarrow{EF} \parallel \overrightarrow{CD}$ ,  $m(\angle CEF) = 95^\circ$ ,

$m(\angle ACE) = 30^\circ$ ,  $m(\angle BAC) = 115^\circ$

Prove that:  $\overrightarrow{AB} \parallel \overrightarrow{EF}$

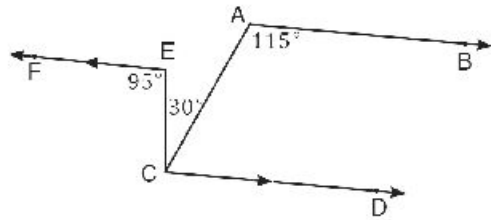

**9** ABCD is a trapezium in which  $\overline{AD} \parallel \overline{BC}$ , E is the mid-point of  $\overline{AB}$ . Draw  $\overrightarrow{EX} \parallel \overline{BC}$  to intersect  $\overline{DB}$  at X and  $\overline{DC}$  at Y, then draw  $\overrightarrow{YZ} \parallel \overline{DB}$  to intersect  $\overline{BC}$  at Z. Prove that:  $XD = YZ$



## Lesson 3

## The triangle

## Theorem (1)

The sum of the measures of the interior angles of a triangle is  $180^\circ$

**Given:** ABC is a triangle

**R . T . P.:**  $m(\angle A) + m(\angle B) + m(\angle ACB) = 180^\circ$

**Construction:** Draw  $\overleftrightarrow{CX} \parallel \overleftrightarrow{AB}$

**Proof:**  $\therefore \angle XCY$  is a straight angle

$\therefore m(\angle XCA) + m(\angle ACB) + m(\angle BCY) = 180^\circ$

$\therefore \overleftrightarrow{XY} \parallel \overleftrightarrow{AB} \therefore m(\angle XCA) = m(\angle \dots)$ , alternate angles ..... (1)

$m(\angle YCB) = m(\angle \dots)$ , alternate angles ..... (2)

by adding (1), (2), then add  $m(\angle ACB)$  to both sides.

$\therefore m(\angle \dots) + m(\angle ABC) + m(\angle \dots) = 180^\circ$  Q . E . D .

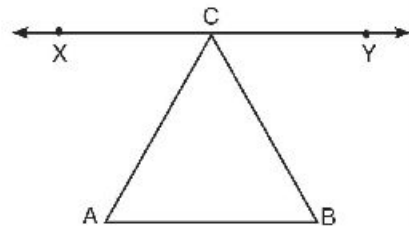

### ● Exterior angle of the triangle.

#### We know that:

A triangle has three interior angles,  
their measures are: a, b, c

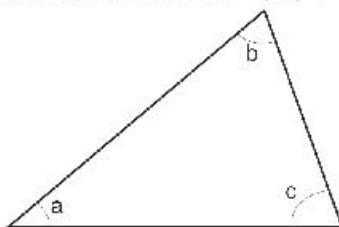

$$\therefore a + b + c = 180^\circ$$

$$\therefore a + b + c = c + d$$

$$\therefore a + b = d$$

If you extend one of the sides, you create  
an exterior angle.

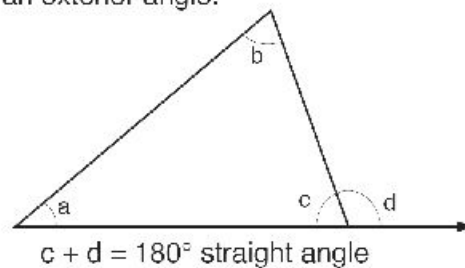

$$c + d = 180^\circ \text{ straight angle}$$

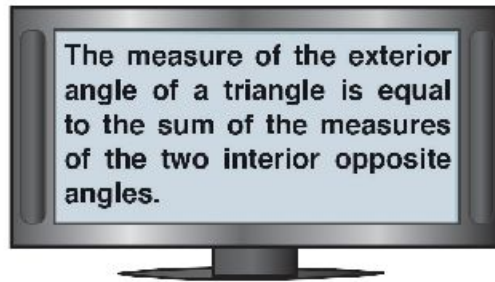

**Complete:**

Do not measure the angles:

**1**

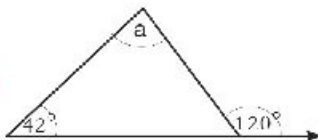

$$a = 120^\circ - 42^\circ = \dots^\circ$$

**2**

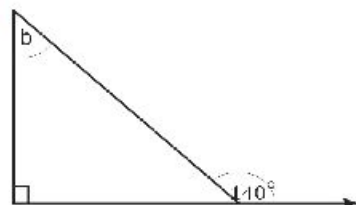

$$b = 140^\circ - \dots^\circ = \dots^\circ$$

**3**

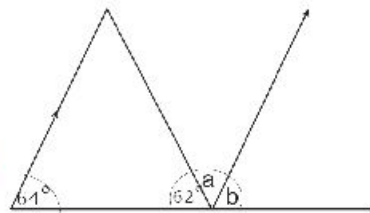

$$b = \dots^\circ \text{ (corresponding angles)}$$

$$a = 180^\circ - (\dots^\circ + \dots^\circ) = \dots^\circ \text{ straight angle.}$$

**4**

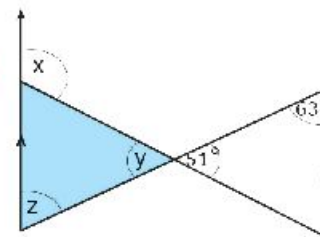

$$y = \dots^\circ \text{ vertically opposite angles}$$

$$z = \dots^\circ \text{ alternate angles}$$

$$x = \dots^\circ \text{ exterior angle of shaded triangle}$$



### Example 1

In the figure opposite:

ABC is a triangle in which:  $D \in \overline{AC}$

$$m(\angle 1) = m(\angle A), m(\angle 2) = m(\angle C)$$

Prove that:  $\angle ABC$  is right

**Solution**

**Given:**  $m(\angle 1) = m(\angle A), m(\angle 2) = m(\angle C)$

**R . T . P.:**  $\angle ABC$  is right

**Proof:**  $\therefore m(\angle 1) = m(\angle A)$

$$m(\angle 2) = m(\angle C) \quad \text{add}$$

$$\therefore m(\angle 1) + m(\angle 2) = m(\angle A) + m(\angle C)$$

$\therefore$  the sum of the measures of the interior angles of a triangle is  $180^\circ$

$$\therefore m(\angle ABC) = m(\angle A) + m(\angle C) = 180^\circ \div 2 = 90^\circ$$

$\therefore \angle ABC$  is right

Q . E . D .

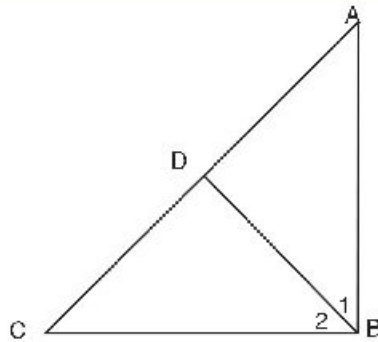

### Example 2

In the figure opposite:

ABC is triangle in which:

$$m(\angle A) = 2m(\angle C), m(\angle B) = 4m(\angle C)$$

Prove that:  $\angle B$  is an obtuse

**Solution**

**Given:**  $m(\angle C) = x, m(\angle A) = 2m(\angle C) = 2x$ , and

$$m(\angle B) = 4m(\angle C) = 4x$$

**R . T . P.:**  $\angle B$  is an obtuse

**Proof:**  $\therefore m(\angle A) + m(\angle C) = x + 2x = 3x, m(\angle B) = 4x$ ,

$$m(\angle B) + m(\angle A) + m(\angle C) = 180^\circ \text{ theorem}$$

$$\therefore m(\angle B) > m(\angle A) + m(\angle C)$$

$\therefore \angle B$  is an obtuse

Q . E . D .

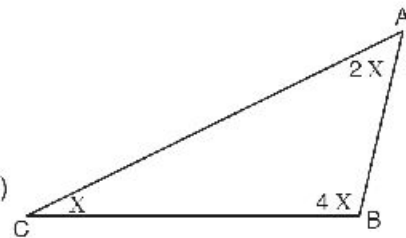

### Theorem (2)

The ray drawn from the midpoint of a side of a triangle parallel to another side bisects the third side

**Given:** D is the midpoint of  $\overline{AB}$  ,  $\overrightarrow{DE} \parallel \overline{BC}$

**R . T . P.:** E is the midpoint of  $\overline{AC}$

**Construction:** Draw  $\overleftrightarrow{AX} \parallel \overline{BC}$

**Proof:**  $\therefore \overrightarrow{AX} \parallel \overrightarrow{DE} \parallel \overline{BC}$  ,  $\overleftrightarrow{AB}$  and  $\overleftrightarrow{AC}$  are two transversals,  
intersect them at D, E respectively,

$$\therefore AD = DB$$

$$\therefore AE = EC$$

Q.E.D

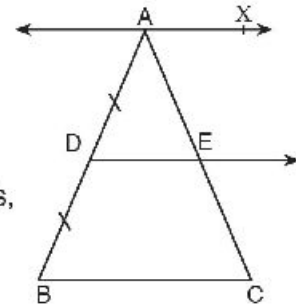

### Corollary

The line segment joining the midpoints of two sides of a triangle is parallel to the third side

### Example

In the figure opposite,  
 $AD = DB$  ,  $AE = EC$ ,

$$\overline{AX} \parallel \overline{BC} , \overrightarrow{DE} \cap \overline{XC} = \{Y\}$$

**Prove that:** Y is the midpoint of  $\overline{XC}$

**Proof:** In  $\triangle ABC$ ,  $\therefore$  D is the midpoint of  $\overline{AB}$ ,  
E is the midpoint of  $\overline{AC}$  }  $\therefore \overline{DE} \parallel \overline{BC}$

$$\therefore \overrightarrow{DE} \parallel \overline{BC}, \quad \overline{AX} \parallel \overline{BC} \quad \left. \vphantom{\begin{matrix} \overrightarrow{DE} \parallel \overline{BC} \\ \overline{AX} \parallel \overline{BC} \end{matrix}} \right\} \therefore \overline{DE} \parallel \overline{AX}$$

In  $\triangle CAX$  ,  $\therefore$  E is midpoint of  $\overline{AC}$  ,

$$\overrightarrow{EY} \parallel \overline{AX} \quad \left. \vphantom{\overrightarrow{EY} \parallel \overline{AX}} \right\} \therefore \overrightarrow{EY} \text{ bisects } \overline{CX}$$

$\therefore$  Y is the midpoint of  $\overline{CX}$

Q.E.D

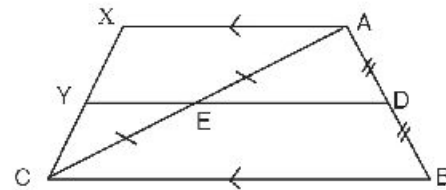



## Theorem (3)

The length of the line segment joining the midpoints of two sides of a triangle is equal to half the length of the third side

**Given:** D is the midpoint of  $\overline{AB}$ ,

E is the midpoint of  $\overline{AC}$

R.T.P:  $DE = \frac{1}{2} BC$

**Construction:** draw  $\overleftrightarrow{EF} \parallel \overline{AB}$  to intersect  $\overline{BC}$  at F

**Proof:** In  $\triangle ABC$ ,  $\therefore$  D is the midpoint of  $\overline{AB}$   
 E is the midpoint of  $\overline{AC}$  }  $\therefore \overline{DE} \parallel \overline{BC}$

$\therefore \overline{EF} \parallel \overline{AB}$ ,  
 E is the midpoint of  $\overline{AC}$  }  $\therefore$  F is the midpoint of  $\overline{BC}$ ,  $BF = \frac{1}{2} BC$

$\therefore$  The quadrilateral BDEF is a parallelogram

$\therefore DE = BF = \frac{1}{2} BC$

Q.E.D

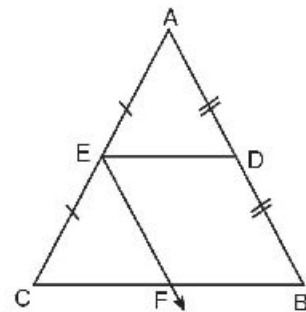

## Example 1

In the figure opposite,

$AB = 5$  cm,  $BC = 8$  cm,  $CA = 7$  cm

D, E, and F are the midpoints of  $\overline{AB}$ ,  $\overline{BC}$ ,  $\overline{CA}$  respectively

calculate the perimeter of  $\triangle DEF$

**Proof:** In  $\triangle ABC$ ,

$\therefore$  D is the midpoint of  $\overline{AB}$ , and

F is the midpoint of  $\overline{AC}$

$\therefore DF = \frac{1}{2} BC = 4$  cm, similarly

$DE = \frac{1}{2} AC = 3.5$  cm,

$EF = \frac{1}{2} AB = 2.5$  cm

$\therefore$  Perimeter of  $\triangle DEF = 4 + 3.5 + 2.5 = 10$  cm

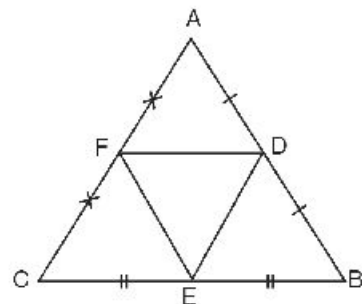

### Example 2

In the figure opposite, ABCD is a quadrilateral in which X, Y, Z, and L are the midpoints of  $\overline{AB}$ ,  $\overline{BC}$ ,  $\overline{CD}$ ,  $\overline{DA}$  respectively.

**Prove that:** XYZL is a parallelogram

**Construction:** draw  $\overline{AC}$  and  $\overline{BD}$

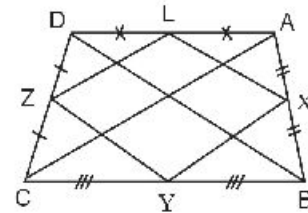

**Proof:** In  $\triangle ABD$ ,  $\therefore X$  is the midpoint of  $\overline{AB}$ ,  
 $L$  is the midpoint of  $\overline{AD}$  }  $\therefore \overline{XL} \parallel \overline{BD}$

Similarly, in  $\triangle CBD$

$$\overline{YZ} \parallel \overline{BD} \therefore \overline{XL} \parallel \overline{YZ} \quad \text{_____} \quad (1)$$

Similarly,  $\overline{XY} \parallel \overline{AC}$ ,  $\overline{LZ} \parallel \overline{AC}$

$$\therefore \overline{XY} \parallel \overline{LZ} \quad \text{_____} \quad (2)$$

From (1) and (2)  $\therefore$  the quadrilateral XYZL is a parallelogram.

Q.E.D

### Drill

In the previous example try, by another way, to prove that: the quadrilateral XYZL is a parallelogram.

### Example 3

In the figure opposite, D and E are the midpoints

of  $\overline{AB}$ , and  $\overline{AC}$  respectively,  $F \in \overrightarrow{CB}$  where

$BF = \frac{1}{2} BC$ . Prove that:

BEDF is a parallelogram

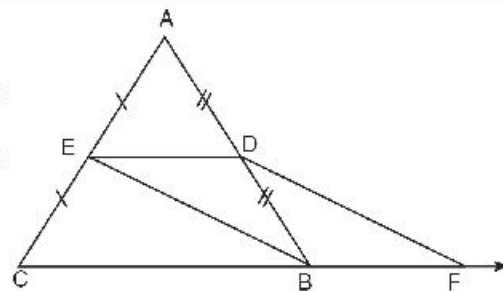

**Proof:** In  $\triangle ABC$ ,  $\therefore D$  is the midpoint of  $\overline{AB}$ ,  
 $E$  is the midpoint of  $\overline{AC}$  }  $\therefore \overline{ED} \parallel \overrightarrow{CB}$ ,  
 $ED = \frac{1}{2} CB$

$\therefore BF = \frac{1}{2} BC \therefore ED = BF$ , but  $\overline{ED} \parallel \overline{BF}$

$\therefore$  The quadrilateral BEDF is a parallelogram

Q.E.D



## Exercise 3-3

Calculate the measure of the unknown angles, giving reasons for your answers.

[a]

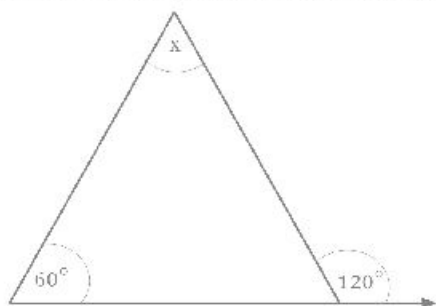

[b]

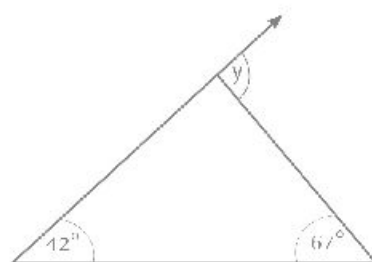

[c]

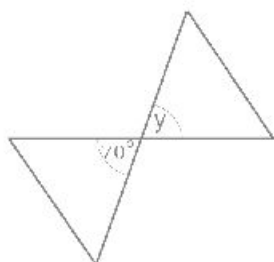

[d]

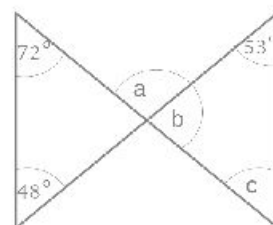

[f]

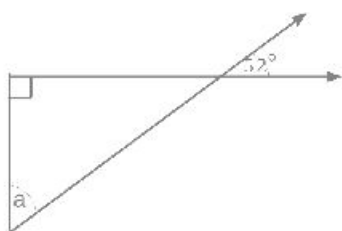

[g]

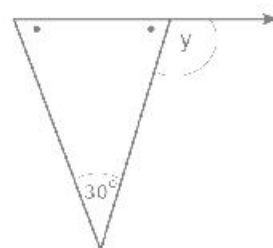

[h]

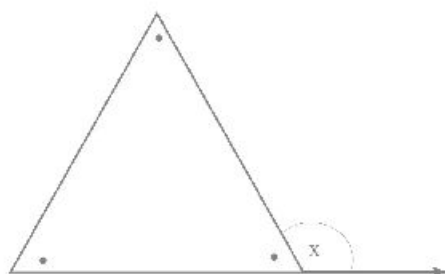

[i]

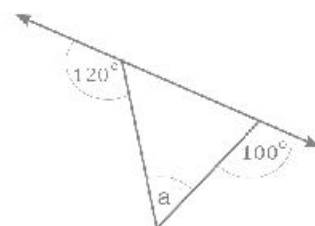

[j]

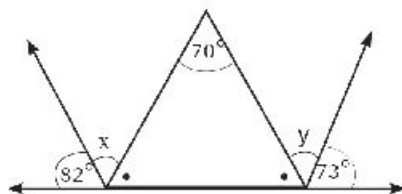

[k]

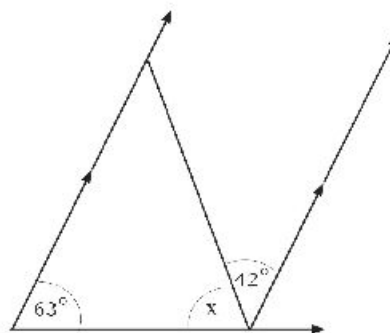

2) In the figure opposite, ABC is a triangle in which,

D, E and F are the midpoints of  $\overline{AB}$ ,  $\overline{BC}$  and  $\overline{CA}$  respectively,

$BC = 12\text{cm}$ ,  $AC = 10\text{cm}$

Find the perimeter of the quadrilateral DECF.

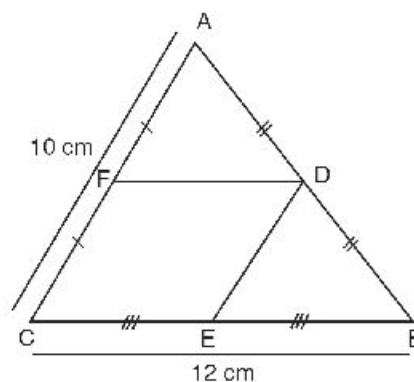

3) In the figure opposite,  $\overline{AD} \parallel \overline{BC}$ ,  $AD = \frac{1}{2} BC$ ,

E is the midpoint of  $\overline{DB}$ , and

F is the midpoint of  $\overline{DC}$ .

**Prove that:**

the quadrilateral AEFD is a parallelogram

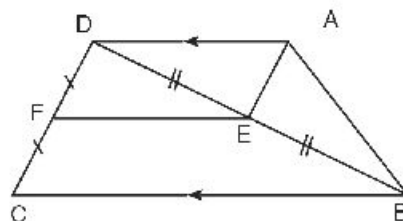

## Lesson 4

## Pythagoras' theorem

In the opposite figure :

Find :

First : Area of the square A

Second : Area of the square B

Third : Sum of the areas of the squares A , B

Fourth : Area of the square C

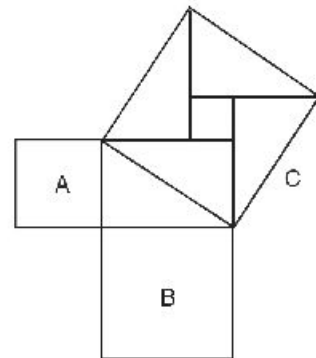

Put the results in the following table :

Area of the square A	Area of the square B	Sum of the areas of the squares A , B	Area of the square C
.....	.....	.....	.....

What is the relation between the sum of the areas of the two squares A,B and the area of the square C?

Activity (1) :

**1** Draw any  $\triangle A B C$  right at A, then construct on its sides the squares as shown in the opposite figure

**2** Determine the center M of the square A C D E ( the intersection point of its diagonals )

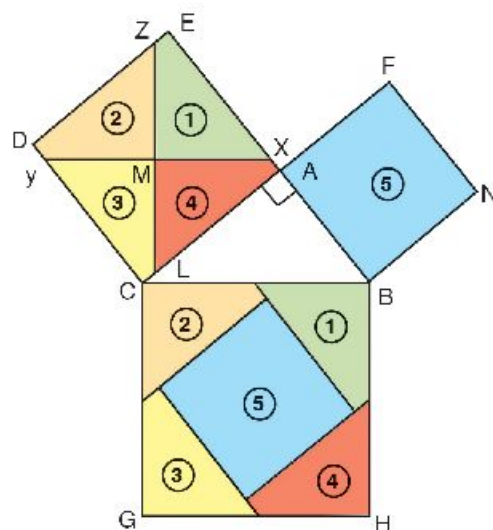

3 Draw  $\overleftrightarrow{Mx} \parallel \overline{BC}$  intersects  $\overline{AE}$  at x,  $\overline{CD}$  at y

4 Draw  $\overleftrightarrow{Mz} \perp \overleftrightarrow{Xy}$  intersects  $\overline{AC}$  at L,  $\overline{ED}$  at z

5 separate the two square regions ABNF, ACDE then divide the region ACDE into the regions (1), (2), (3) and (4), then try to stick these regions with the parts which carry the corresponding numbers of the square BCGH

6 If your work which you have done and your drawing were accurate you will find that the corresponding parts exactly congruent with each other .

and we deduce that :

Area of the square region BCGH =

area of the square region ABNF + the area of the square region ACDE

this means that :

Area of the square which drawn on  $\overline{BC}$  =

area of the square drawn on  $\overline{AB}$  + area of the square drawn on  $\overline{AC}$  .

Repeat again you will reach to the previous result .

7 can you formulate findings in the form of the verbal form .

### Activity (2) :

ABCD is a square, its side lengths are

divided as in the opposite figure, where

$AX = m$  unit length ,

$XB = n$  unit length .

First : prove that the four triangles in the

opposite figure are congruent.

( two sides, included angle )

Second : Prove that the figure XYZL is a square .

Third : This implies that the area of the square XYZL = Area of the square

ABCD – 4 area of  $\triangle XBY$

i . e  $(xy)^2 = (m + n)^2 - 4 \times \frac{1}{2}mn$

$= m^2 + 2mn + n^2 - 2mn$

$\therefore (xy)^2 = m^2 + n^2$

, then we reach to **Pythagoras' theorem**

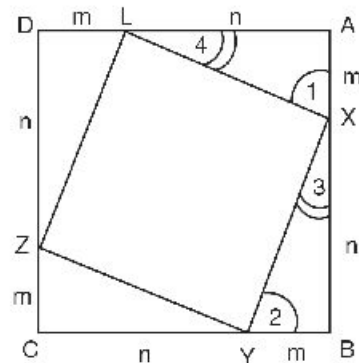

### Pythagoras theorem

In the right-angled triangle, area of the square drawn on the hypotenuse equals sum of the areas of the squares drawn on the other two sides.

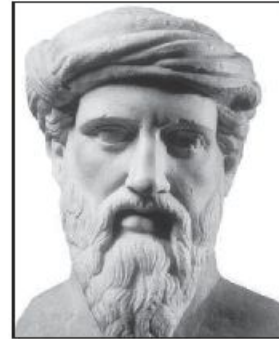

**Pythagoras**  
(582-501 B.C)

i. e in  $\triangle ABC$  :  
if  $m(\angle B) = 90^\circ$   
, then  $(BA)^2 + (BC)^2 = (AC)^2$

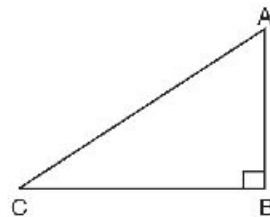

### Example

ABC is a right-angled triangle at B, find the length of the third side in  $\triangle ABC$  if :

First :  $AB = 3 \text{ cm}$  ,  $BC = 4 \text{ cm}$

Second :  $AB = 5 \text{ cm}$  ,  $AC = 13 \text{ cm}$

### Solution :

First :  $\therefore \triangle ABC$  is right at B

$$\begin{aligned}\therefore (AC)^2 &= (AB)^2 + (BC)^2 \\ &= 9 + 16 = 25\end{aligned}$$

$$\therefore AC = \sqrt{25} = 5 \text{ cm}$$

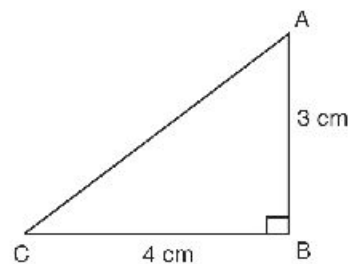

Second :  $\therefore \triangle ABC$  is right at B

$$\begin{aligned}\therefore (BC)^2 &= (AC)^2 - (AB)^2 \\ &= 169 - 25 = 144\end{aligned}$$

$$\therefore BC = \sqrt{144} = 12 \text{ cm}$$

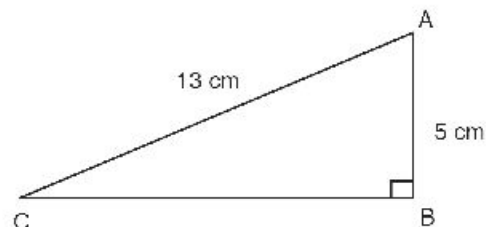

### Exercise 3-4

- 1** ABC is a right-angled triangle at B, if  $BC = 4.5$  cm,  $AC = 7.5$  cm Find the length of  $\overline{AB}$

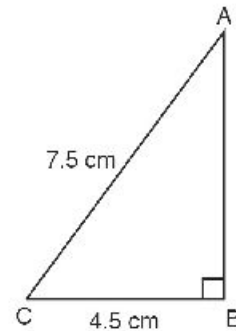

- 2** XYZL is a quadrilateral in which  $m(\angle XYZ) = m(\angle XLZ) = 90^\circ$ ,  $XY = 7$  cm,  $YZ = 24$  cm,  $XL = 15$  cm. Find the length of  $\overline{XZ}$ ,  $\overline{LZ}$

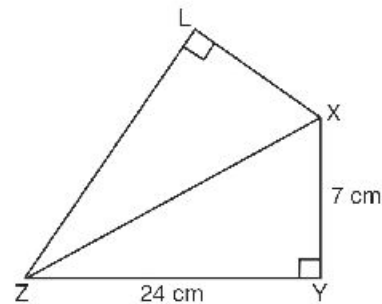

- 3** ABC is a triangle,  $\overline{AD} \perp \overline{BC}$  if  $AD = 24$  cm,  $AB = 26$  cm,  $AC = 30$  cm Find BC, the area of  $\triangle ABC$

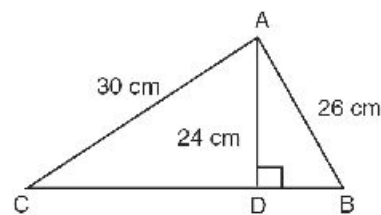

- 4** ABCD is a trapezium, where  $\overline{AD} \parallel \overline{BC}$ ,  $m(\angle DCB) = 90^\circ$ ,  $\overline{AE} \perp \overline{BC}$  and  $AB = BC = 17$  cm,  $AD = 9$  cm. Find the length of  $\overline{DC}$ , the area of the trapezium.

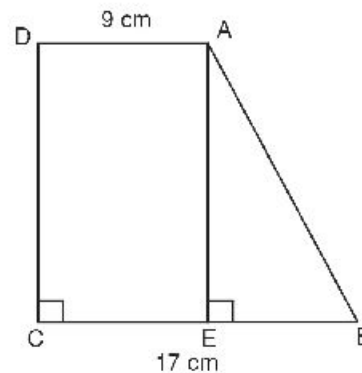



## Lesson 5

## Geometric transformations

When a geometric figure is transferred to another one it is said that it is under the effect of a geometric transformation.

Some common transformations are illustrated:

Reflection

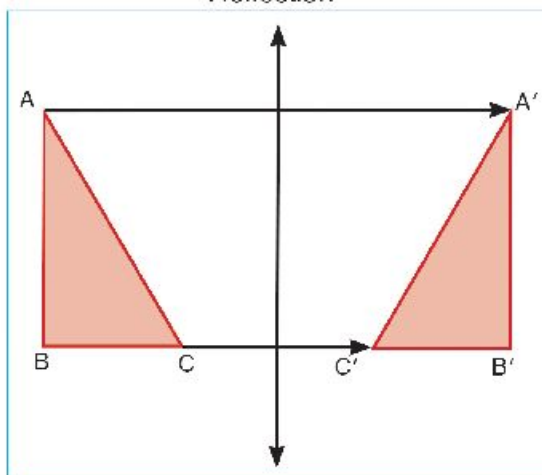

Translation

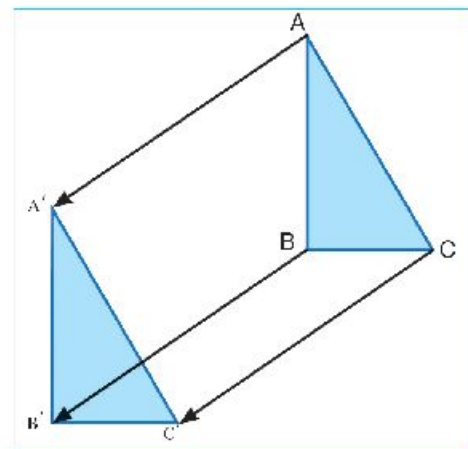

Rotation

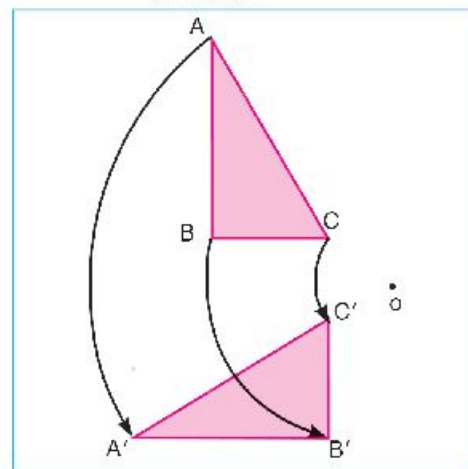

In each of the three diagrams there is a relation between corresponding points of the two triangles.

A is transferred to  $A'$  :  $A \longrightarrow A'$

B is transferred to  $B'$  :  $B \longrightarrow B'$

C is transferred to  $C'$  :  $C \longrightarrow C'$

$A'$ ,  $B'$ , and  $C'$  are the images of points A, B, and C.

A transformation transforms every point  $p$  in a plane onto an image point  $p'$  in the same plane.

## Example

Find the image of  $\triangle ABC$  where  $A(1, 2)$ ,  $B(3, 2)$  and  $C(3, 5)$  by the following geometric transformations:

1)  $(x, y) \longrightarrow (x, -y)$

2)  $(x, y) \longrightarrow (x + 1, y - 3)$

3)  $(x, y) \longrightarrow (-y, x)$

## Solution

1)  $\therefore (x, y) \longrightarrow (x, -y)$

$\therefore A(1, 2) \longrightarrow A'(1, -2)$ ,

$B(3, 2) \longrightarrow B'(3, -2)$ ,

$C(3, 5) \longrightarrow C'(3, -5)$

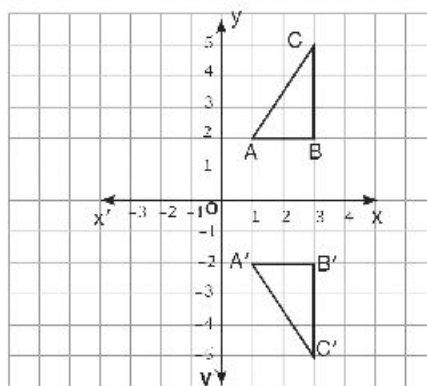

2)  $\therefore (x, y) \longrightarrow (x + 1, y - 3)$

$\therefore A(1, 2) \longrightarrow A'(2, -1)$ ,

$B(3, 2) \longrightarrow B'(4, -1)$ ,

$C(3, 5) \longrightarrow C'(4, 2)$

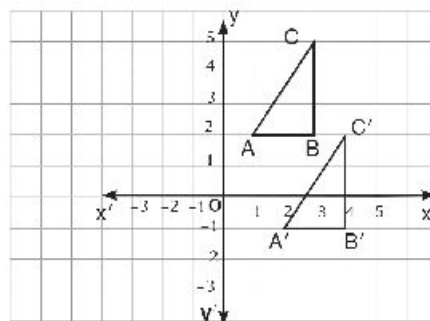

3)  $\therefore (x, y) \longrightarrow (-y, x)$

$\therefore A(1, 2) \longrightarrow A'(-2, 1)$ ,

$B(3, 2) \longrightarrow B'(-2, 3)$ ,

$C(3, 5) \longrightarrow C'(-5, 3)$

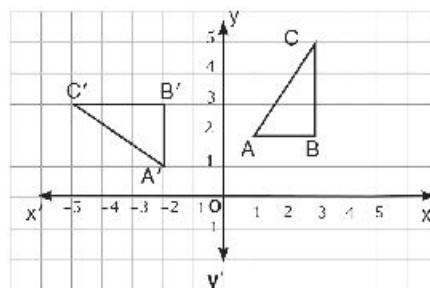

**Exercise 3-5**

**1** Describe the type of transformation in each of the following figures: (reflection - translation - rotation)

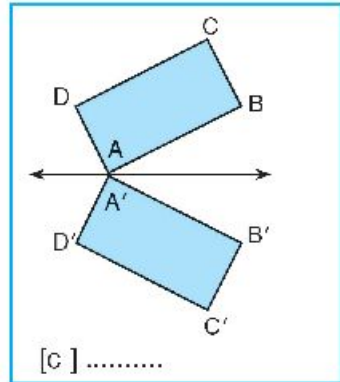
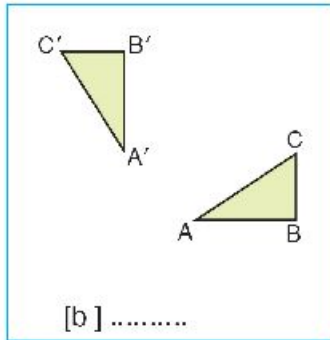
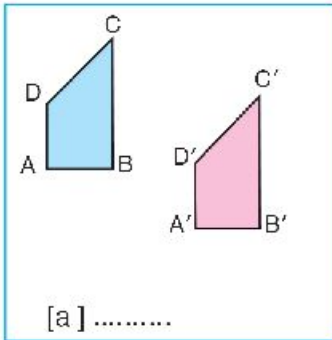

**2** Draw the image of each figure according to the shown transformation, then describe each type:

[a]  $(x, y) \longrightarrow (x, -y)$    [b]  $(x, y) \longrightarrow (-x, -y)$    [c]  $(x, y) \longrightarrow (x + 2, y + 3)$

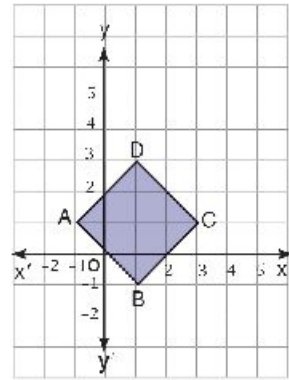
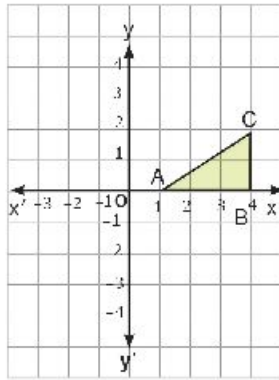
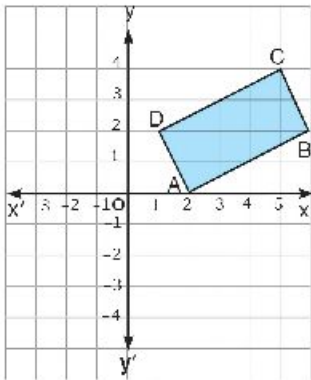

**3** Draw the image of polygon A B C D E O according to each transformation, and describe the type:

[a]  $(x, y) \longrightarrow (-x, y)$

[b]  $(x, y) \longrightarrow (x, y + 5)$

[c]  $(x, y) \longrightarrow (-x, -y)$

[d]  $(x, y) \longrightarrow (x - 5, y)$

[e]  $(x, y) \longrightarrow (x, -y)$

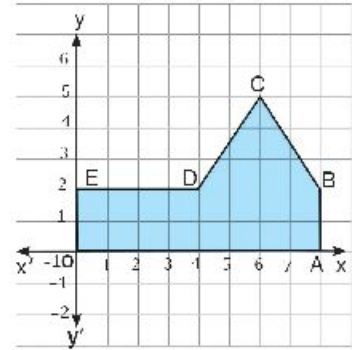

## Lesson 6

## Reflection

When you stand before a mirror, your image appears to be as far behind the mirror as you are in front of it.

The diagram shows a transformation in which a straight line acts like a mirror.

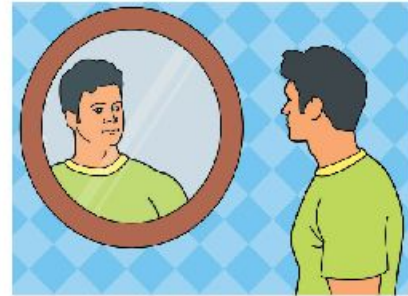

## Reflection in a straight line

A reflection in a straight line  $L$  maps every point  $P$  to a point  $p'$  such that:

- 1) If  $P \notin L$ , then  $L$  is the perpendicular bisector of  $\overline{pp'}$
- 2) If  $Q \notin L$ , then  $L$  is the perpendicular bisector of  $\overline{QQ'}$
- 3) If  $S \in L$ , then its image is itself ( $S = S'$ )

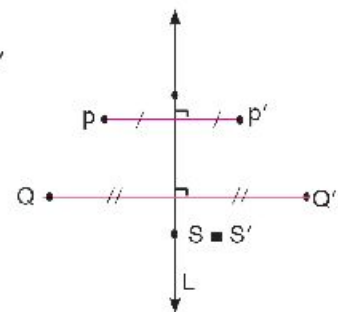

## Example 1

- 1) Draw the image of point  $A$  by reflection in the straight line  $L$ .

## Solution

From  $A$ , draw an arc to cut  $L$  at  $B$  and  $C$ .

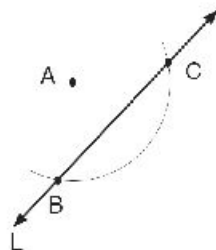

With  $B$  and  $C$  as two centres and same radius length, draw two arcs to intersect at  $A'$

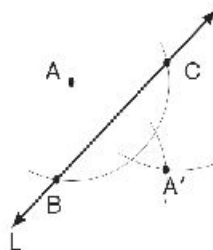

$A'$  is the image of  $A$  by reflection in  $L$

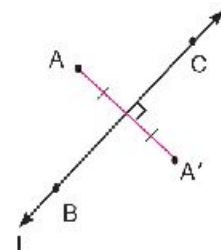

Check by measuring that  $L$  is the perpendicular bisector of  $\overline{AA'}$

### Example 2

Draw the image of  $\overline{AB}$  by reflection in the straight line  $L$ .

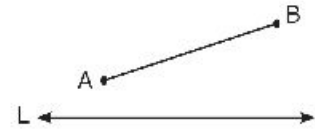

#### Solution

Draw the image of  $A$  and  $B$  by reflection in  $L$

Draw  $\overline{A'B'}$

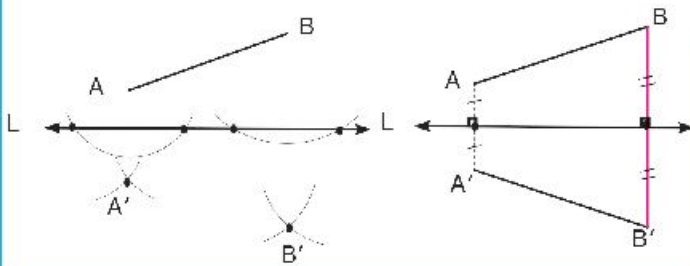

$\overline{A'B'}$  is the image of  $\overline{AB}$  by reflection in  $L$ . Check by measuring that  $L$  is the perpendicular bisector of each of  $\overline{AA'}$  and  $\overline{BB'}$  and that  $\overline{A'B'} \cong \overline{AB}$

### Example 3

Draw the image of  $\triangle ABC$  by reflection in the straight line  $L$ .

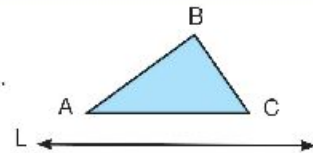

#### Solution

Draw the image of each of the points  $A, B$ , and  $C$  by reflection in  $L$ .

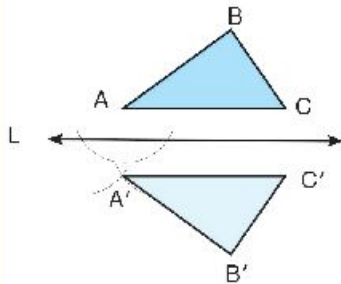

$\triangle A'B'C'$  is the image of  $\triangle ABC$  by reflection in  $L$

Compare, by measuring between the elements of  $\triangle ABC$ , and  $\triangle A'B'C'$  then complete:

- [1] The straight line  $L$  is the perpendicular bisector of: ....., ....., and .....
- [2] The reading of  $\triangle ABC$  is clockwise while the reading of  $\triangle A'B'C'$  is .....
- [3]  $AB = \dots\dots\dots$ ,  $BC = \dots\dots\dots$ ,  $CA = \dots\dots\dots$
- [4]  $m(\angle A) = m(\angle \dots)$ ,  $m(\angle B) = m(\angle \dots)$ ,  $m(\angle C) = m(\angle \dots)$
- [5] Reflection is a geometrical transformation which transforms a geometrical shape into another one that is ..... to it.

## Exercise 3-6

- 1 Copy the figures below in your notebook, then find the images of  $A$ ,  $\overline{AB}$ ,  $\triangle ABC$  by reflection in  $L$ :

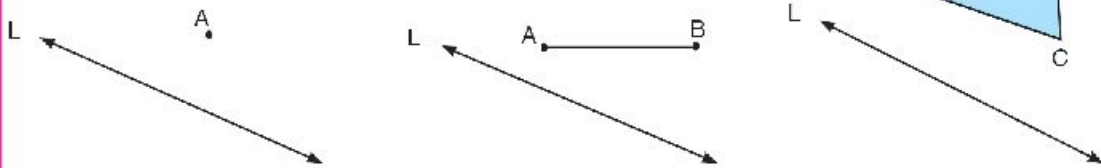

- 2 Copy the figures below in your notebook, then draw the images of  $\triangle DEF$  and the circle  $M$  by reflection in  $L$ .

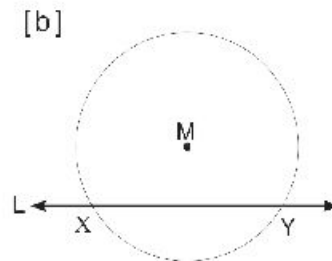
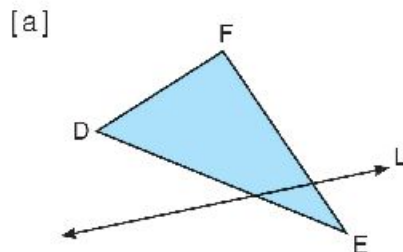

- 3 Draw the image of  $\triangle XYZ$  in which  $XY = 3$  cm,  $YZ = 5$  cm, and  $ZX = 7$  cm by reflection in the straight line containing the longest side.
- 4 Draw the image of  $\triangle ABC$  in which  $AB = 3$  cm,  $BC = 4$  cm, and  $AC = 5$  cm by reflection in the straight line containing the shortest side.
- 5 In the figure opposite:

When the word "MOM" is reflected in a vertical line, the image is still "MOM". Write other words that are unchanged when reflected in a vertical line?

When the word "DECK" is reflected in a horizontal line, the image is still "◀DECK▶".

Write other words that are unchanged when reflected in a horizontal line?

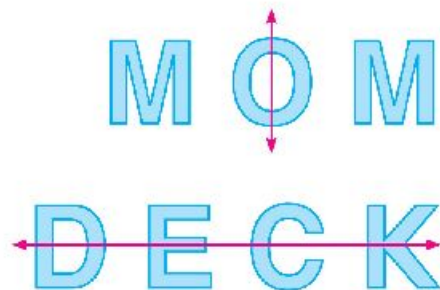

## Reflection in cartesian plane

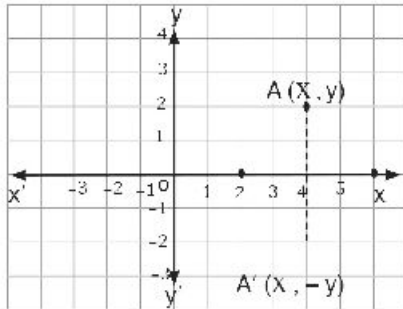

Reflection in the x-axis maps:  
 $A(x, y) \rightarrow A'(x, -y)$ .

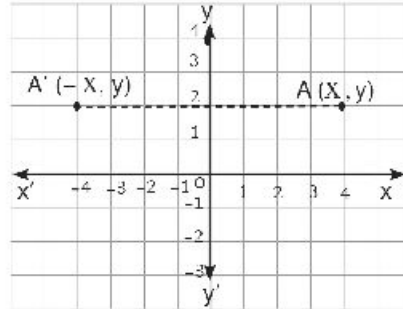

Reflection in the y-axis maps:  
 $A(x, y) \rightarrow A'(-x, y)$ .

### Example 1

On the lattice, Find image of the triangle LMN where  
 $L(-4, -1)$ ,  $M(-1, -3)$ ,  $N(0, -1)$  by reflection on the X-axis

### Solution

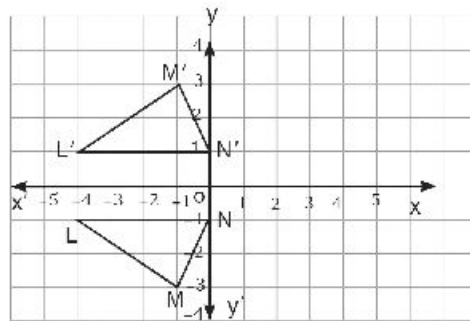

The images are:  $L'(-4, 1)$ ,  $M'(-1, 3)$ , and  $N'(0, 1)$



## Properties of reflection in a coordinate plane

You have learned before the reflection as a geometric transformation that transforms a geometric figure into another congruent geometric figure.

The properties of reflection in a coordinate plane are represented through the following example:

### Example 2

In perpendicular coordinate plane where:

ABCD is a rectangle, where A (1,1), B (5,1), C (5,4) and D (1,4)

**Find:**

I: The image of the rectangle ABCD by reflection in the X-axis.

II: The image of the rectangle ABCD by reflection in the Y-axis.

**Solution:**

**First:** Reflection in the X-axis:

**Let** :  $A'$  is the image of A (1,1)

$$\therefore A' (1, -1)$$

$B'$  is the image of B (5,1)

$$\therefore B' (5, -1)$$

$C'$  is the image of C (5,4)

$$\therefore C' (5, -4)$$

$D'$  is the image of D (1,4)

$$\therefore D' (1, -4)$$

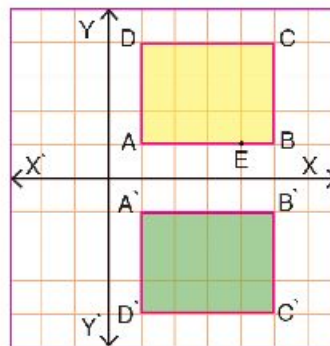

Thus, the rectangle  $A',B',C',D'$  is the image of the rectangle ABCD by reflection in the X-axis.

### Second: Reflection across y-axis:

Let:  $A''$  is the image of  $A(1,1)$   $\therefore A''(-1, 1)$

$B''$  is the image of  $B(5,1)$   $\therefore B''(-5, 1)$

$C''$  is the image of  $C(5,4)$   $\therefore C''(-5, 4)$

$D''$  is the image of  $D(1,4)$   $\therefore D''(-1, 4)$

Thus, the rectangle  $A''B''C''D''$  is the image of the rectangle  $ABCD$  by reflection in the Y-axis.

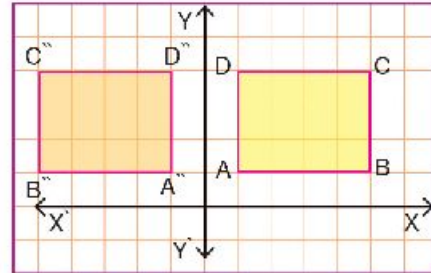

Find the measure of each side length of the rectangle  $ABCD$  and compare it with its image. What do you notice?

### You know :

In the rectangle  $ABCD$   $\overline{AB} \parallel \overline{DC}$  and  $\overline{BC} \parallel \overline{AD}$

is  $\overline{A'B'} \parallel \overline{D'C'}$  and  $\overline{B'C'} \parallel \overline{A'D'}$  ?

is  $A''B'' \parallel D''C''$  and  $B''C'' \parallel A''D''$  ? What can you conclude?

is the rectangle  $ABCD$  congruent to the rectangle  $A'B'C'D'$  ?

is the rectangle  $ABCD$  congruent to the rectangle  $A''B''C''D''$  ?

If the point  $E \in \overline{AB}$ , determine the point  $E'$  as an image for the point  $E$  by reflection in the X-axis? Is  $E' \in \overline{A'B'}$  ?

### Properties of reflection in a line

- 1 Reflection reserves lengths of segments.
- 2 Reflection reserves betweenness property.
- 3 Reflection reserves measures of angles.
- 4 Reflection reserves parallelism.

Does the reflection reserve the orientation of the vertices of figures?

Does the order of the rectangle whose points are  $ABCD$  the same as its image by reflection in  $L$ ?

**Practice:**

Draw the image of  $\triangle ABC$  by reflection in the y-axis in each case:

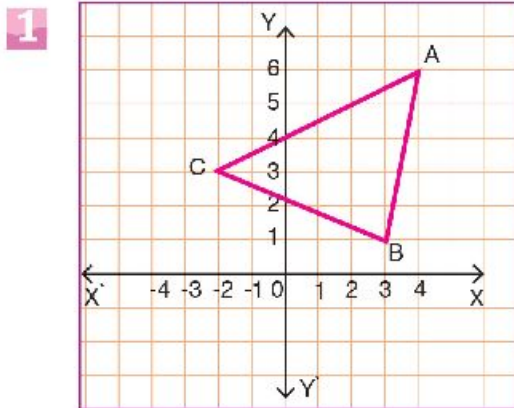
**Complete:**

$$A(4, 6) \rightarrow A'(-4, 6)$$

$$B(\dots, \dots) \rightarrow B'(\dots, \dots)$$

$$C(\dots, \dots) \rightarrow C'(\dots, \dots)$$

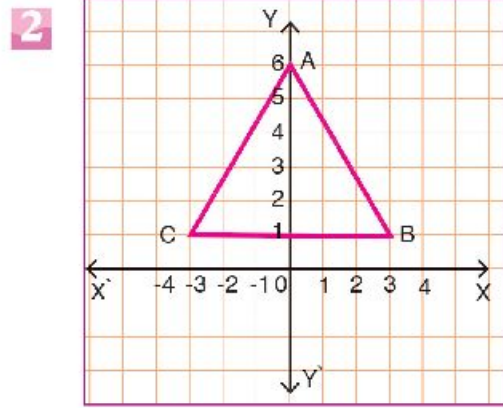
**Complete:**

$$A(0, 6) \rightarrow A'(0, 6)$$

$$B(\dots, \dots) \rightarrow B'(\dots, \dots)$$

$$C(\dots, \dots) \rightarrow C'(\dots, \dots)$$

**Note that:**

If the reflection in a line transform the figure to itself, then this line is called an axis of symmetry of the figure.

**In the second figure:** the y-axis  $YY'$  is the axis of symmetry of  $\triangle ABC$ .

**Let's think**

Determine the number of axes of symmetry of each figure below:

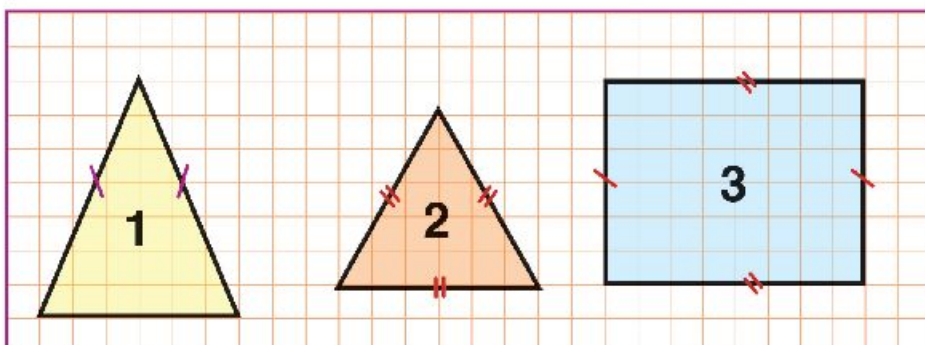

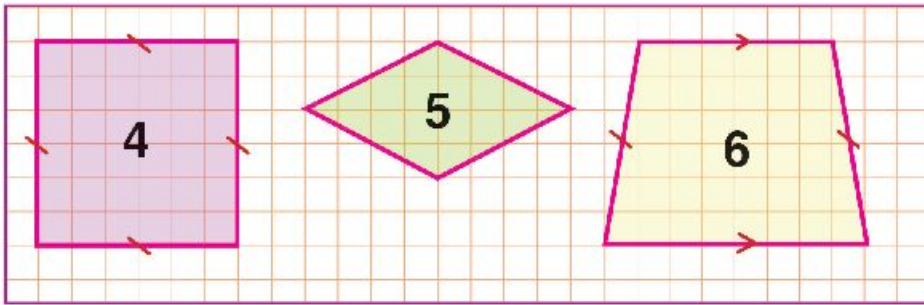

- (1) Isosceles triangle.
- (2) Equilateral triangle.
- (3) Rectangle.
- (4) Square.
- (5) Rhombus.
- (6) Isosceles trapezium.

**Practice:**

**In the opposite figure:**

$\triangle ABC$  is an equilateral triangle, where D, E and F are the midpoints of  $\overline{AB}$ ,  $\overline{BC}$  and  $\overline{AC}$  respectively, and  $\overline{AE} \cap \overline{BF} \cap \overline{CD} = \{M\}$  :

**Complete:**

- 1** Axes of symmetry of  $\triangle ABC$  are .....
- 2**  $\overline{AB}$  is the reflected image of  $\overline{AC}$  by reflection in .....
- 3** The reflected image of  $\overline{AF}$  by reflection in  $\overleftrightarrow{BF}$  is ....., and the reflected image of  $\overline{CF}$  in  $\overleftrightarrow{AE}$  is .....
- 4** The reflected image of  $\triangle AMD$ . by reflection in  $\overleftrightarrow{AE}$  is .....

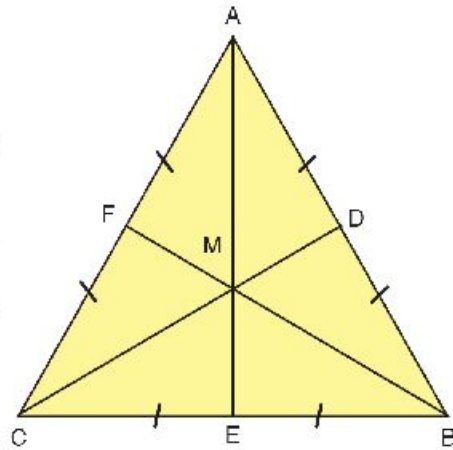

- $\therefore m(\angle AMD) = m(\angle \dots)$ , because reflection in a line reserves .....
- 5** The reflected image of  $\triangle AMB$  by reflection in  $\overleftrightarrow{AE}$  is .....
- 6**  $\triangle BMC$  is the reflected image of ..... by reflection in  $\overleftrightarrow{CD}$ , and the reflected image of ..... by reflection in  $\overleftrightarrow{BF}$ .
- $\therefore BM = AM$ , and  $CM = AM$ , because the reflection reserves .....

## Reflection around a Point

### Reflection in a Point

Reflection in a Point  $M$  maps each point  $A$  in the plane to its image  $A'$  in the same plane so that  $M$  is the midpoint of  $\overline{AA'}$ . The point  $M$  is called the centre of reflection and its image by reflection in  $M$  is itself.

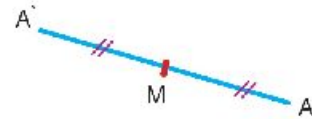

**Therefore, a reflection is an isometry.**

**Example:**

**In the opposite figure:**

$M \notin \overline{AB}$  Find the reflected image of  $\overline{AB}$  around point  $M$ .

**Solution:**

- 1 Draw  $\overrightarrow{AM}$  and locate  $A'$  on  $\overrightarrow{AM}$ , so that  $A'M = AM$
- 2 Draw  $\overrightarrow{BM}$  and locate  $B'$  on  $\overrightarrow{BM}$ , so that  $B'M = BM$
- 3 Draw  $\overline{A'B'}$
- 4 For each point  $C \in \overline{AB}$ , locate  $C'$  on  $\overrightarrow{CM}$ , so that  $C'M = CM$ . Is  $C' \in \overline{A'B'}$ ?  
 $\therefore \overline{A'B'}$  is the reflected image of  $\overline{AB}$ , around  $M$ .

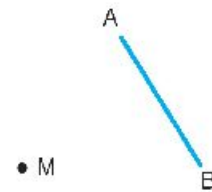

### Reflection around a point

- 1 Reserves the lengths of the line segments.
- 2 Reserves the measures of angles.
- 3 Reserves the parallel property.

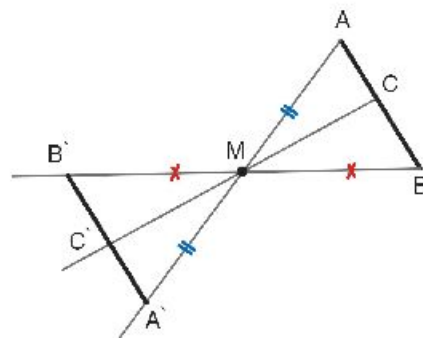

## Reflection in the origin point in a perpendicular coordinate plane.

Reflection in the origin point  $O(0, 0)$  maps  
 $A(x, y) \rightarrow A'(-x, -y)$ .

**For example:** The reflected image of  $A(-3, 2)$  in the origin is  $A'(3, -2)$ .

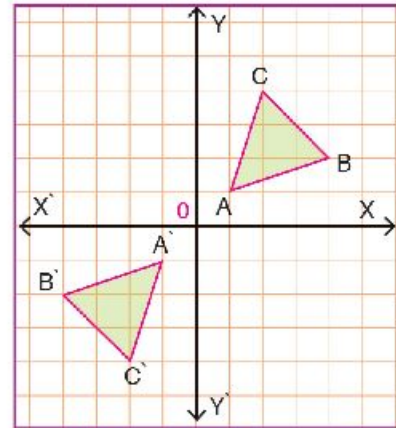

### Example:

**In the opposite figure:**  $\triangle A'B'C'$  is the reflected image of  $\triangle ABC$  in  $O$ , where  $A(1, 1)$ ,  $B(4, 2)$  and  $C(2, 4)$ .

### Practice:

**1** Draw on the opposite perpendicular grid:

$\triangle ABC$ , where  $A(-2, 1)$ ,  $B(4, -3)$  and  $C(2, 3)$ ,

then complete:

$A(-2, 1) \xrightarrow[\text{in } (0, 0)]{\text{Reflection}} A'(\dots, \dots)$

$B(4, -3) \longrightarrow B'(\dots, \dots)$

$C(\dots, \dots) \longrightarrow C'(\dots, \dots)$

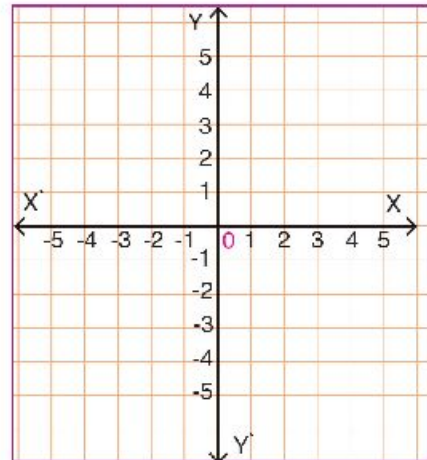

Draw  $\triangle A'B'C'$ , the reflected image of  $\triangle ABC$  in origin point  $O$ .

### Note that:

Reflection in a point reserves orientation of the vertices of the figure.



## Exercise 3-7

- 1** In the figure below, write the coordinates of the image of each point by reflection in:

[a] The  $x$  - axis      [b] The  $y$  - axis

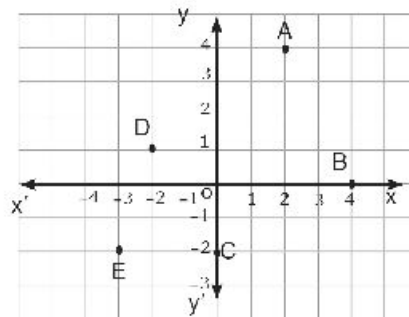

- 2** Find the image of point  $P(2, 4)$  and  $\triangle ABC$  where  $A(-6, -1)$ ,  $B(-2, -1)$  and  $C(-5, -6)$  by reflection in the  $X$ -axis
- 3** The points  $A(-4, 5)$ ,  $B(2, 4)$ ,  $C(5, -1)$ ,  $D(x, y)$  are reflected in the  $X$  - axis, state the coordinates of their images.
- 4** The points  $E(0, 5)$ ,  $F(6, 3)$ ,  $G(-3, 1)$ , and  $H(x, y)$  are reflected in the  $Y$  - axis, state the coordinates of their images.
- 5** Identify the points that have  $A'(2, -3)$ ,  $B'(-1, 2)$ , and  $C'(3, 1)$  as their images by reflection in the  $Y$  - axis, then graph all the points.
- 6** Graph the square  $ABCD$  and its image: by reflection in the  $X$ -axis then compare the length of the sides and the area  $A(0, 2)$ ,  $B(-5, 0)$ ,  $C(-3, -5)$  and  $D(2, -3)$ .
- 7** Draw the image of square  $ABCD$  where  $A(2, 3)$  and  $B(2, -1)$ , by reflection in the  $Y$ -axis - what do you notice?
- 8** Draw the image of the rectangle  $ABCD$  where  $A(2, 2)$ ,  $D(-3, 2)$ , with width 3 units by reflection in the  $X$ -axis. How many cases can you draw?

**9 By using geometric instruments:**

Draw rectangle ABCD, where AB = 3cm. BC = 4 cm. Locate A' the reflected image of A by reflection in  $\overleftrightarrow{CD}$  and locate C' the reflected image of C by reflection in  $\overleftrightarrow{AB}$ , Prove that:

**First:**  $m(\angle C'AC) = 2m(\angle CAB)$

**Second:**  $\overleftrightarrow{AC'} \parallel \overleftrightarrow{A'C}$

**10** In xy-coordinate plane draw  $\triangle ABC$ , where:

A (-2, 4), B ( 5, 0 ), and C (3, -3 ), then find:

**First:** The reflected image of  $\triangle ABC$  by reflection in the X-axis.

**Second:** The reflected image of  $\triangle ABC$  in the origin.

**11** In the opposite figure:

ABCD is a rectangle, M is the point of intersection of the diagonals,  $X \in \overline{AD}$ ,  $\overleftrightarrow{XM} \cap \overline{BC} = \{y\}$ .

**Prove that:**

**First:** y is the reflected image of X in M.

**Second:** The figure AXCy is a parallelogram.

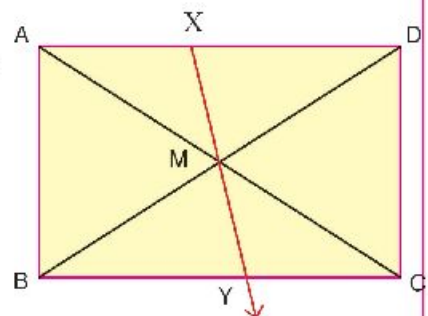

**12** In the opposite figure: ABCD is a parallelogram

M is the point of intersection of its diagonals.

$X \in \overline{AC}$ ,  $Y \in \overline{AC}$ ,

$m(\angle ABX) = m(\angle CDY)$

**Prove that:**

**First:**  $\triangle ABX$  the image of  $\triangle CDY$  by reflection in M.

**Second:** The figure XBYD is a parallelogram.

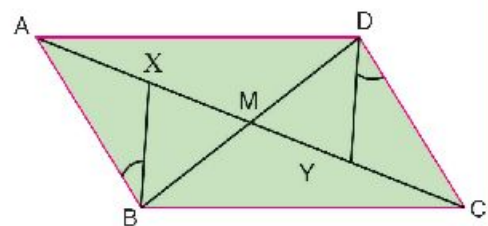



## Lesson 7

## Translation

The picture suggests a transformation called a translation.

A translation can be thought of as a transformation that glides all points of the plane  $A, B, C, \dots$ , the same distance, in the same direction such that:

$$AA' = BB' = CC', \\ \overline{AA'} \parallel \overline{BB'} \parallel \overline{CC'}$$

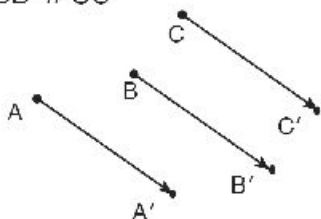

## Example 1

Draw the image of  $A$  by the translation  $MN$ , in the direction of  $\overrightarrow{MN}$ .

**solution**

Draw, from  $A$ , a ray parallel to  $\overrightarrow{MN}$  and in the same direction.

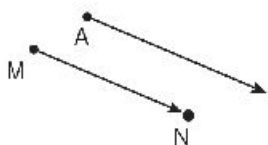

With  $A$  as a centre and radius length  $MN$ , draw an arc to intersect the ray at  $A'$ .

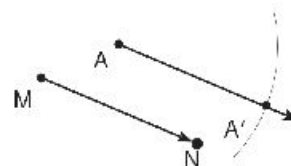

$A'$  is the image of  $A$  by translation with magnitude  $MN$  and in the direction of  $\overrightarrow{MN}$ .

$$AA' = MN \\ \overline{AA'} \parallel \overline{MN}$$

### Example 2

Draw the image of  $\overline{AB}$  by the translation of magnitude  $MN$ , in the direction of  $\overrightarrow{MN}$ .

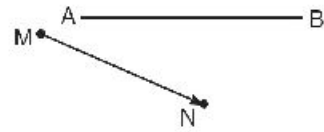

#### solution

Draw from A and B two rays parallel to  $\overrightarrow{MN}$  and in the same direction.

With A and B as centres, and radius length equals  $MN$ , draw two arcs to intersect the two rays at  $A', B'$ .

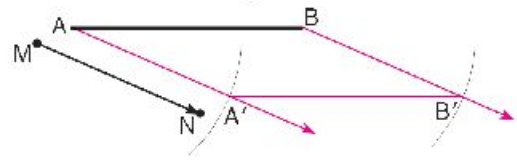
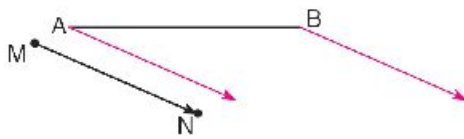

Check by measuring that  $\overline{AB} \parallel \overline{A'B'}$  and  $AB = A'B'$   
 $\overline{A'B'}$  is the image of  $\overline{AB}$  by the translation of magnitude  $MN$ , in the direction of  $\overrightarrow{MN}$

### Example 3

Find the image of  $\triangle DEF$  by the translation of magnitude  $MN$ , in the direction of  $\overrightarrow{MN}$ .

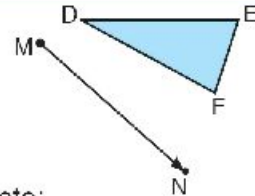

#### solution

Draw from D, E, and F rays parallel to  $\overrightarrow{MN}$  and in the same direction.

Complete:

- 1)  $DE = \dots$ ,  $EF = \dots$ ,  $FD = \dots$
- 2)  $m(\angle D) = m(\angle \dots)$ ;  
 $m(\angle E) = m(\angle \dots)$ ;  
 $m(\angle F) = m(\angle \dots)$

Determine  $D', E', F'$  such that

$$DD' = FF' = EE' = MN$$

Join the points  $D', E'$  and  $F'$

3) Translation is a geometrical transformation which transforms a geometrical shape into another that is ..... to it.

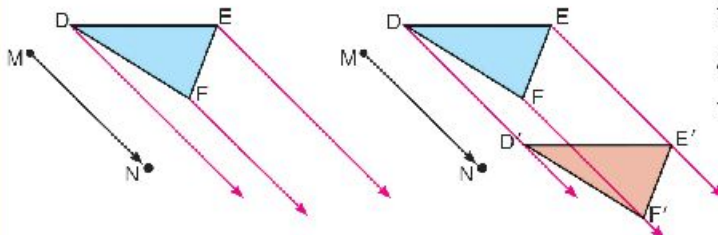

$\triangle D'E'F'$  is the image of  $\triangle DEF$  by the translation of magnitude  $MN$ , in the direction of  $\overrightarrow{MN}$ .



## Exercise 3-8

- 1** Copy the figures below in your notebook, then find the images of  $A$ ,  $\overline{CD}$ ,  $\triangle XYZ$ , and  $ABCD$  by the translation of magnitude  $MN$ , in the direction of  $\overrightarrow{MN}$ :

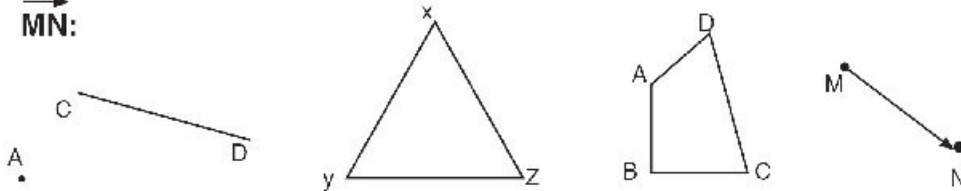

- 2** Draw a line segment  $\overline{AB}$ , where  $AB = 5$  cm, then draw the image of  $\overline{AB}$  by a translation of magnitude of 8 cm in the direction of  $\overrightarrow{AB}$
- 3** Draw  $\triangle ABC$  in which  $AB = 4$  cm,  $BC = 6$  cm, and  $CA = 5$  cm, then draw the image of  $\triangle ABC$  by a translation of magnitude 3 cm in direction of  $\overrightarrow{CB}$ .

- 4** In the figure opposite:

$ABCD$  is a square, and all the interior squares are congruent, complete:

- [a] The image of  $\overline{AE}$  by a translation of magnitude 2 cm in the direction of  $\overrightarrow{PK}$  is .....
- [b] The image of the square  $AENM$  by a translation of magnitude 4 cm in the direction of  $\overrightarrow{PK}$  is .....
- [c] The square  $MNHP$  is the image of the square  $GLZK$  by a translation of magnitude ..... in the direction of .....

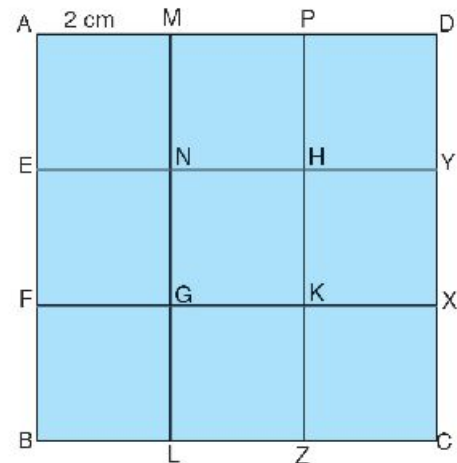

- 5** In the figure opposite:

The triangles  $ADF$ ,  $BDE$ ,  $DEF$ , and  $EFC$  are congruent, complete:

- [a] The image of  $\triangle ADF$  by a translation of magnitude  $AD$  in the direction of  $\overrightarrow{AD}$  is .....
- [b]  $\triangle FEC$  is the image of  $\triangle DBE$  by a translation of magnitude ..... in the direction of .....

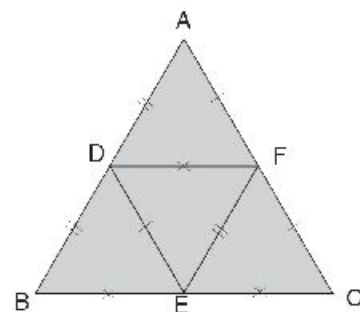

**6** ABC is a right angled triangle at B, where AB = 3 cm and BC = 4 cm.

If

$\triangle A'B'C'$  the image of  $\triangle ABC$  by translation of 3 cm

in the direction of  $\vec{CB}$ .

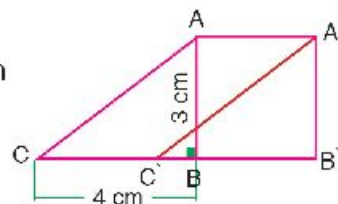

**Prove that :**

the figure  $AA'C'B'$  is a parallelogram.

**7** In the opposite figure: ABCD is a square whose side length is 4 cm .

M is the point of intersection of its diagonals. **Draw.**

(a) The image of  $\triangle MAB$ , by translation 2 cm in the direction of  $\vec{AD}$

(b) The image of  $\triangle AMB$ , by translation AM units in the direction of  $\vec{AM}$

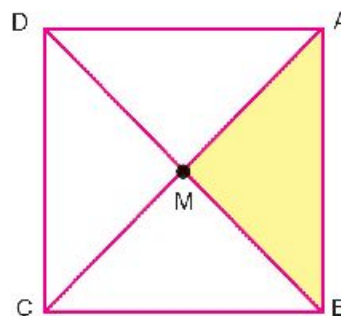

## Translation in the cartesian plane

The translation transforms each point two displacements, one in direction of the  $x$  – axis ( $a$ ) followed by another one in direction of the  $y$  – axis ( $b$ ).

$$A(x, y) \longrightarrow A'(x + a, y + b)$$

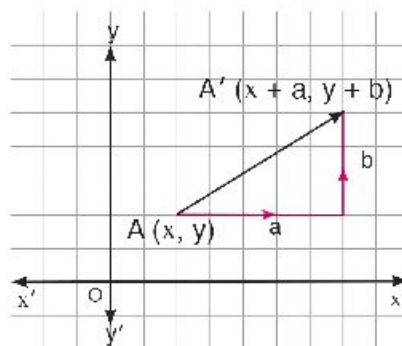

**1** [a] Find the images of the points shown in the table under the translation:

$$(x, y) \longrightarrow (x + 3, y - 2)$$

$(x, y)$	$(x + 3, y - 2)$
$(-3, 5)$	$(0, 3)$
$(1, 0)$	$( \quad , \quad )$
$(4, 4)$	$( \quad , \quad )$

[b] Join each point to its image.  
What do you notice?

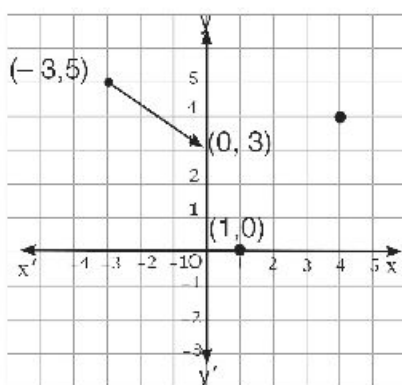

- The transformation is a translation of ..... units to the right and ..... units down.
- The line segments appear to be ..... in length and .....

**2** Draw the images of each of following points by translation with magnitude  $\overrightarrow{AB}$  in the direction  $\overrightarrow{AB}$  where  $A(3, 4)$  and  $B(7, 2)$

[a]  $C(3, 2)$

[b]  $D(-1, 3)$

[c]  $E(x, y)$

The translation is equivalent to a horizontal displacement from 3 to 7 which equals 4 units, and a vertical displacement from 4 to 2 equals -2 units

$$C(3, 2) \longrightarrow C'(\dots, \dots)$$

$$D(-1, 3) \longrightarrow D'(\dots, \dots)$$

$$E(x, y) \longrightarrow E'(x + 4, y - 2)$$

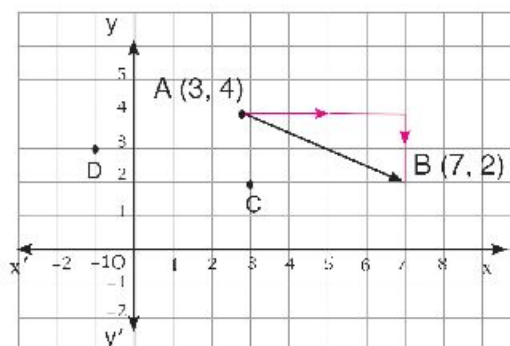

## Properties Translation in the plan

- 1 Translation preserves lengths of line segments and the distance between points.
- 2 Translation preserves the measures of angles.
- 3 Translation preserves parallelism of lines.

### Example:

Find  $\overline{A'B'}$ , the translated image of  $\overline{AB}$ , where  $A(2, 1)$  and  $B(2, 4)$ , translated  $\overline{MN}$  units in the direction of  $\overrightarrow{MN}$  where  $M(-2, 5)$  and  $N(3, 7)$ .

### Solution:

Translating  $\overline{MN}$  units in the direction of  $\overrightarrow{MN}$  is equivalent to horizontal displacement from -2 to 3 =  $3 - (-2) = 5$  units.

vertical displacement from 5 to 7 =  $7 - 5 = 2$  units.

$\therefore$  Translation = (5, 2)

$\therefore A' = (2 + 5, 1 + 2) = (7, 3)$

$B' = (2 + 5, 4 + 2) = (7, 6)$

Draw  $\overline{A'B'}$  to get the image of  $\overline{AB}$

Is  $\overline{A'B'} \parallel \overline{AB}$  ?

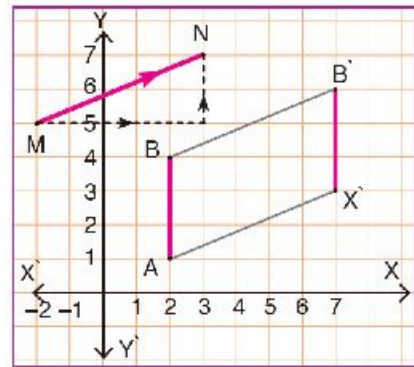

### Let's think:

Refer to the previous example: When drawing  $\overline{A'B'}$ :

Is  $m(\angle A'AB') = m(\angle BB'A)$  ? Why ?

Is  $\triangle A'AB' \cong \triangle B'BA$  ? Why ?

Is  $\overline{A'B'} \parallel \overline{AB}$  ?

Is the figure  $ABA'B'$  a parallelogram ?

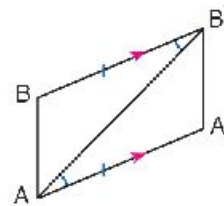

### We can conclude :

For any quadrilateral, if two opposite sides are equal in length and parallel, then this quadrilateral is a parallelogram.

### Note that:

the translated image of a line segment is another line segment parallel to the original and equal to it in length.



## Exercise 3-9

- 1** Copy the graph, then draw the image of the parallelogram ABCD under each of the following translations:

[a]  $(x, y) \longrightarrow (x + 5, y + 2)$

[b]  $(x, y) \longrightarrow (x - 8, y - 1)$

[c]  $(x, y) \longrightarrow (x + 2, y - 4)$

[d]  $(x, y) \longrightarrow (x - 4, y + 2)$

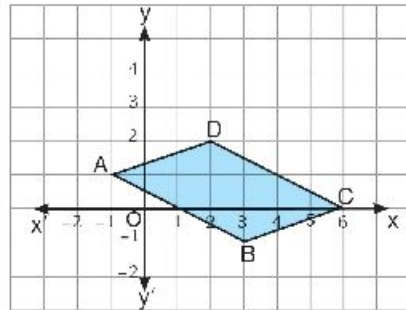

- 2** Using the lattice, find the image of each of the following points by the translation of LM in the direction of  $\overrightarrow{LM}$  where L (1, 3) and M (4, 5).

[a] B (-2, 3)

[b] C (5, 4)

[c] D (3, 0)

- 3** Use the translation:  $(x, y) \longrightarrow (x + 2, y + 3)$  to locate the point whose image is (2, 3).

- 4** In the figure opposite:

Copy the graph, then draw the triangle ABC whose image is  $A'B'C'$  by the translation:

$(x, y) \longrightarrow (x + 2, y + 3)$ .

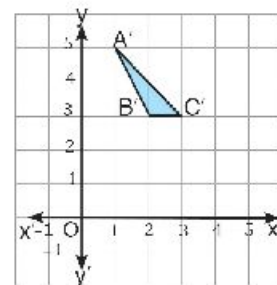

- 5** If the image of the point A (1, 1) by translation in the plane is  $A'$  (2, 2), find the images of the points O (0, 0), B (-1, 3) and C (-3, 5) by the same translation.

- 6** A square has vertices A (1, 1), B (4, 2), C (3, 5) and D (0, 4).

[a] Graph the square and its image under the translation AB in the direction of  $\overrightarrow{AB}$ .

[b] Write the mapping rule for the translation.

- 7** The point  $A'$  (3, -3) is the image of the point A by the translation:

$(x, y) \longrightarrow (x - 1, y - 4)$ . locate A then by the same translation, draw the image of  $\triangle ABC$  where B (5, 0) and C (-1, -2).

**Rotation around a point in a plane**

Rotation around a point  $M$  with an angle whose measure is  $E$  is a geometric transformation in which each point  $A$  in the plane is rotated to another point  $A'$  in the same plane, so that:

$$\diamond m(\angle AMA') = E$$

$$\diamond MA' = MA$$

Rotation is denoted by  $R(M, E)$ ,  $M$  where:

**1**  $M$  is the centre of rotation.

**2**  $E$  is the measure of the angle of rotation.

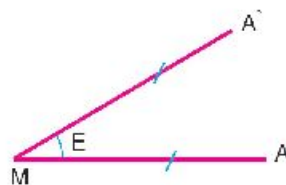
**Note that:**

**1** Rotation is well defined as the centre of rotation is determined, the measure of the angle of rotation, is known and the direction of rotation is known as well.

**2** The direction of rotation is positive, if the rotation is in anticlockwise and is negative if the rotation is in clockwise.

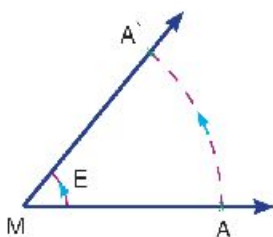

$A'$  is the rotational image of  $A$ , around  $M$  with an angle whose measure is  $(E)$

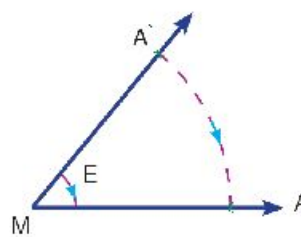

$A$  is the rotational image of  $A'$ , around  $M$  with an angle whose measure is  $(-E)$



Finding the rotational image of a line segment by a well known rotation.

### Example

Draw  $\overline{A'B'}$ , the image of  $\overline{AB}$  by  $R(M, 120^\circ)$

To draw  $\overline{A'B'}$  follow the following steps:

- 1 Draw  $\overrightarrow{MA}$
- 2 Draw  $\angle AMX$ , Whose measure =  $120^\circ$   
(Note that the rotation direction)
- 3 With the compasses and with centre M and draw an arc of a circle with length radius MA. intersects  $\overrightarrow{MX}$  at point  $A'$   
then  $A'$  is the rotational image of A by the rotation  $R(M, 120^\circ)$
- 4 Repeat the same steps to find  $B'$  the image of B. by the rotation  $R(M, 120^\circ)$ .
- 5 For each  $C \in \overline{AB}$ , determine  $C'$  the image of C by rotation  $R(M, 120^\circ)$ .
- 6 Draw  $\overline{A'B'}$  and notice  $C' \in \overline{A'B'}$
- 7 Find the lengths of:  $\overline{AB}$ ,  $\overline{A'B'}$ ,  $\overline{AC}$ ,  $\overline{A'C'}$ ,  $\overline{CB}$ , and  $\overline{C'B'}$ .

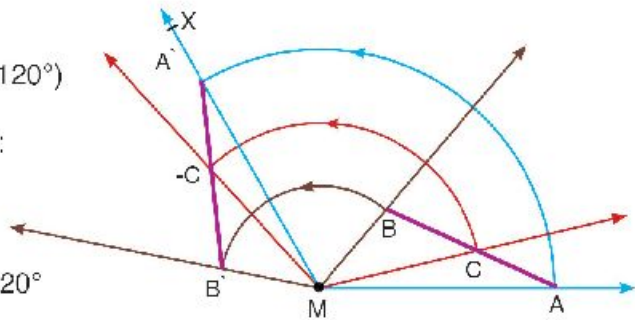

Does rotation preserves distances?

Does rotation preserves collinearity?

### Practice

- 1 In the opposite figure: The radius of circle M is 3cm.  $\overline{AC}$  and  $\overline{BD}$  are two perpendicular diameters complete.

[a] By the rotation  $R(M, 90^\circ)$ , then:

the rotational image of point A is .....

the rotational image of point B is .....

the rotational image of  $\overline{AB}$  is .....

the rotational image of  $\overrightarrow{AB}$  is .....

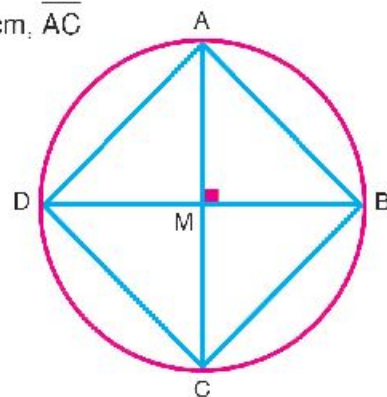

[b] By the rotation  $R(M, -90^\circ)$ , then the rotational image of  $\overline{AB}$  is ....., the rotational image of  $\overrightarrow{AB}$  is ....., and the rotational image of  $\overleftarrow{AB}$  is .....

[c] By the rotation  $R(M, 180^\circ)$ , then:

the rotational image of A is ....., and the rotational image of B is .....

$\therefore$  The rotational image of  $\overline{AB}$  is .....

[d] By the rotation  $R(M, -180^\circ)$ , then the rotational image of  $\overline{AB}$  is .....

### Practice

**2** In the opposite figure: ABCD is a square. O is the point of intersection of its diagonals.

X, Y, Z, L are midpoints of sides  $\overline{AB}$ ,  $\overline{BC}$ ,  $\overline{CD}$ ,  $\overline{DA}$  and respectively. **Find:**

[a] The image of  $\triangle AXO$  by reflection in  $\overleftrightarrow{AO}$ , followed by another reflection in  $\overleftrightarrow{LO}$ .

[b] The image of  $\triangle AXO$  by rotation  $R(O, 90^\circ)$ .

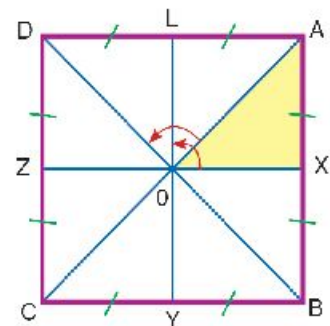

### Rotation in the coordinate plane around the origin (O)

#### In the opposite figure

**1** A (4, 2) is a point in the perpendicular coordinate plane  
A' is the rotational image of A by  $R(O, 90^\circ)$ .

**Note that:**  $OA = OA'$ ,  $m(\angle AOA') = 90^\circ$  Refer to the figure, we find that A' (-2, 4)

$$\text{i.e. } A(x, y) \xrightarrow[\text{R}(O, 90^\circ)]{\text{Rotation}} A'(-y, x).$$

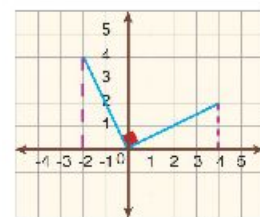

**Think:** Is  $R(O, 90)$  equivalent to  $R(O, -270^\circ)$ ? Why?

**2** Draw B (3, 4), and B' the image of B by  $(O, 180^\circ)$ .

**Note that:**  $OB = OB'$ ,  $m(\angle BOB') = 180^\circ$  and rotation anticlockwise. Refer to the figure, we find that B' (-3, -4).

**Think** Is rotation  $R(O, 180^\circ)$  equivalent to  $R(O, -180^\circ)$ ? Why?

Which rotation is equivalent to  $R(O, 270^\circ)$ ?

Find the image of A by rotation  $R(O, 360^\circ)$  and the image of B by rotation  $R(O, -360^\circ)$ .

### Neutral Rotation

Neutral rotation is a rotation with an angle of  $360^\circ$  or  $-360^\circ$ . The image of each point coincides exactly with itself. This rotation is called **neutral** because it maps the figure to its original position.

### Practice

Complete the following table as shown in the first row:

Point	Rotational Image by rotation around O and an angle whose measure is				
	$90^\circ$	$180^\circ$ or $-180^\circ$	$270^\circ$	$360^\circ$	$-90^\circ$
A (2, 5)	(-5, 2)	(-2, -5)	(5, -2)	(2, 5)	(5, -2)
B ( , )				(-1, 3)	
C ( , )		(2, -3)			
D ( , )			(-4, -1)		
E ( , )	(3, -5)				

### Think

- 1 Does rotation preserves distance and collinearity?
- 2 Does rotation preserves the measures of angles?
- 3 Does rotation preserves the parallel of lines?

*Rotation in a plane is a geometric transformation maps any figure to another congruent figure. Therefore, Rotation is an isometry. It preserves also orientation of the vertices of any figure.*

### Exercise 3-10

**1** Draw the axes of symmetry of each figure below if existed:

[a]

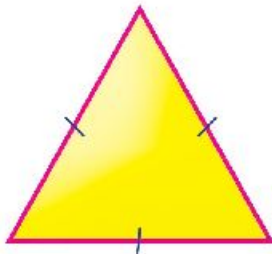

[b]



[c]



[d]



[E]

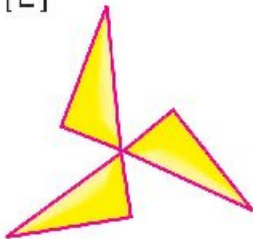

[F]

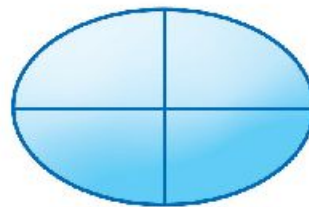

**2** Draw  $\triangle ABC$  in which  $AB = 5\text{cm}$ ,  $AC = 3\text{cm}$ , and  $m(\angle A) = 40^\circ$ ,

Draw  $C'$ , the image of  $C$  by  $R(A, 40^\circ)$  and  $B'$ , the image of  $B$  by  $R(A, -40^\circ)$ .

**3**  $\triangle ABC$  is a right-angled triangle with  $AB = 5\text{ cm}$ , and  $BC = 12\text{ cm}$ . **Find:**

[a]  $X$ , the image of  $B$ , by translation  $9\text{ cm}$  in the direction of  $\overrightarrow{BA}$ .

[b]  $Y$ , the image of  $B$  by rotation  $R(A, -90^\circ)$

[c] **Find** the length of  $\overline{XY}$ .

- 4** Draw the equilateral triangle ABC with side length 6 cm. Draw the image of the triangle ABC by rotation  $R(A, 60^\circ)$ .
- 5** Draw the square ABCD with side length 5 cm. Draw the image of the square ABCD:  
[a] By rotation  $R(A, 90^\circ)$   
[b] By rotation  $R(A, 180^\circ)$
- 6** Draw the triangle ABC in which  $AB = 5$  cm,  $BC = 6$  cm,  $AC = 7$  cm.  
Draw the image of the triangle ABC:  
[a] By rotation  $R(B, 180^\circ)$   
[b] By rotation  $R(A, 360^\circ)$
- 7** Draw the rectangle ABCD in which  $BC = 6$  cm,  $AB = 4$  cm. Draw the image of the rectangle ABCD:  
[a] By rotation  $R(A, 90^\circ)$   
[b] By rotation  $R(M, 180^\circ)$  where M is the point of intersection of its diagonals.

### Activities:

**1** State whether the graph shows a reflection or a translation.

[a] Name the line of reflection

[b] Describe the translation.

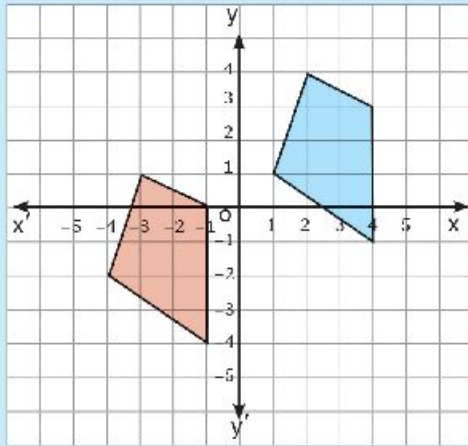

(1)

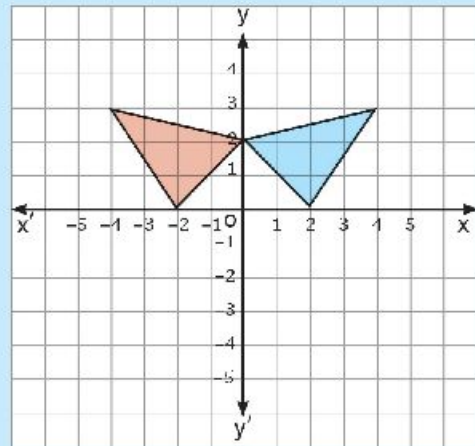

(3)

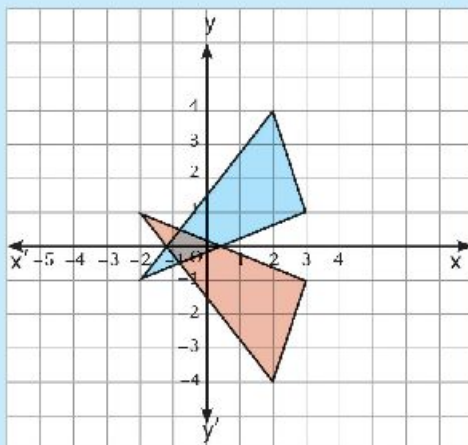

(2)

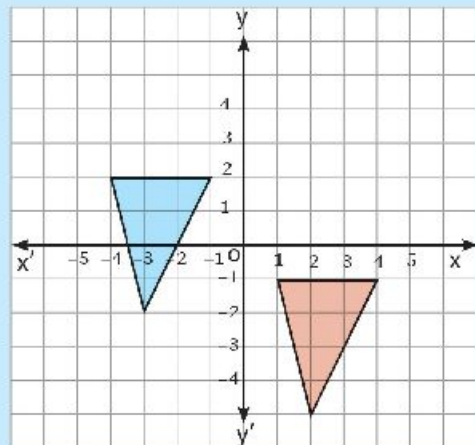

(4)

- 2** Figure b is the image of figure a by a geometric transformation. Identify each transformation as a translation, a reflection, or a rotation.

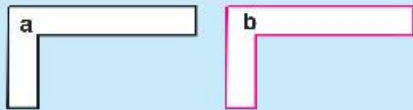

(1)

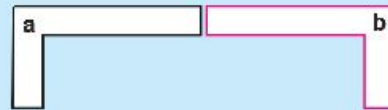

(2)

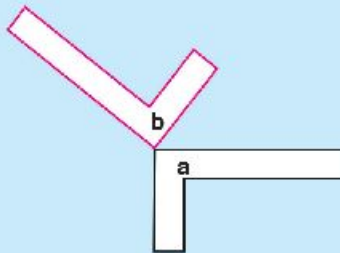

(3)

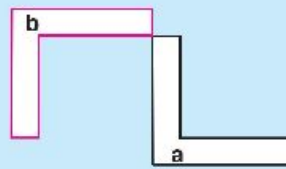

(4)

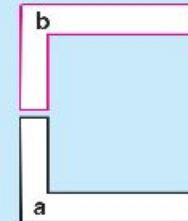

(5)

- 3** On graph paper, draw rectangle ABCD with vertices at A (0, 0), B (0, 2), C (4, 2) and D (4, 0).

[a] Draw three images formed by rotating the rectangle about the origin through an angle of measure:

- 1)  $90^\circ$       2)  $180^\circ$       3)  $270^\circ$

[b] What are the coordinates of the center of the rectangle?

[c] Draw three images formed by rotating the rectangle about its center through an angle of measure:

- 1)  $90^\circ$       2)  $180^\circ$       3)  $270^\circ$

## Unit test

**1** Mark (✓) for the correct statement and (×) for the incorrect one:

[a] The image of the point (3, 4) by reflection in the X-axis is (3, -4)

[b] The point whose image is (y, -x) by rotation about the origin with an angle of measure 90° is (x, y).

[c] The image of the point (5, -3) under the translation (x + 2, y + 4) is (7, 1).

**[d] In the figure opposite:**

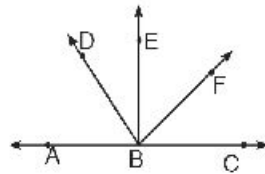

1) If  $\angle EBC$  is right angle, then  $BE \perp AC$ .

2) If  $\angle ABE$  is right angle, then  $m(\angle ABE) = 90^\circ$

3) If  $BE \perp AC$ , then  $\angle ABD$  and  $\angle DBE$  are complementary.

4) If  $\angle ABE = \angle CBE$ , then  $BE \perp AC$

**2** Calculate the measure of the unknown angle in each of the following:

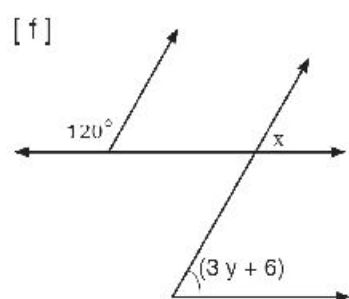
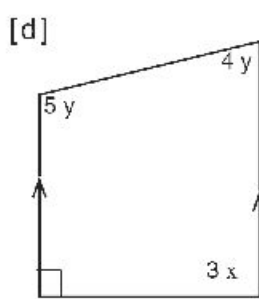
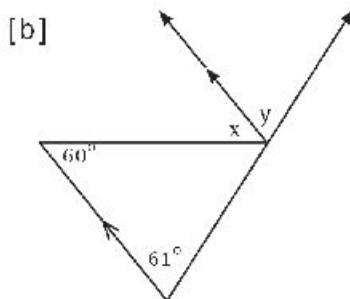
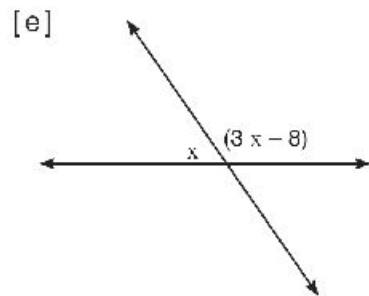
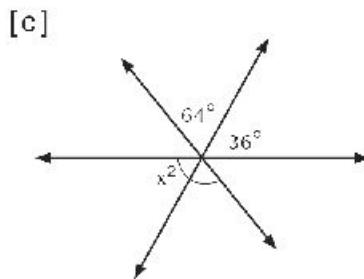
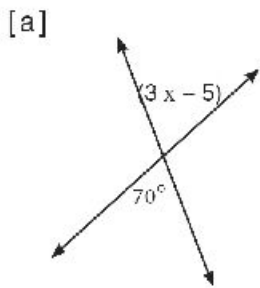



**3** [a] If the image of the point A by reflection in the X-axis is (2, 1), locate the point A, then draw its image by reflection in the Y-axis.

[b] Draw the triangle XYZ in which  $XY = XZ = 3$  cm and  $YZ = 4$  cm, draw the image of  $\triangle XYZ$  by rotation about the vertex X with an angle of measure  $-90^\circ$ .

**4** Referring to this figure:

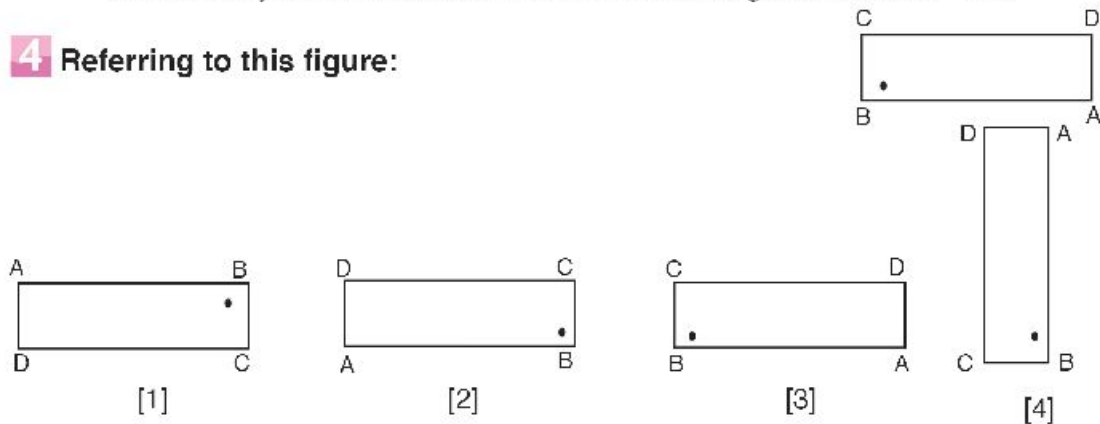

- [a] The image of the figure by reflection in  $\overleftrightarrow{AD}$  is [1, 2, 3, 4].
- [b] The image of the figure by rotation about A with  $90^\circ$  is [1, 2, 3, 4].
- [c] The image of the figure by translation to the right is [1, 2, 3, 4].
- [d] The image of the figure by rotation about A with  $180^\circ$  is [1, 2, 3, 4].

**5** In The figure opposite,

- $E \in \overline{BC}$ ,  $m(\angle BAE) = 45^\circ$ ,  
 $m(\angle AEB) = 70^\circ$ ,  $m(\angle D) = 65^\circ$   
 and  $m(\angle C) = 115^\circ$

Prove that: the quadrilateral ABCD is a parallelogram

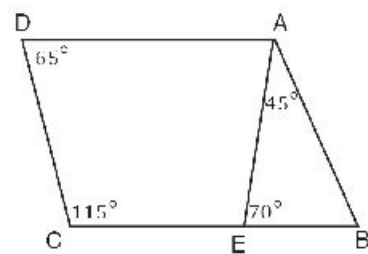

**6** [a] Evaluate the measure of the unknown angle in each figure:

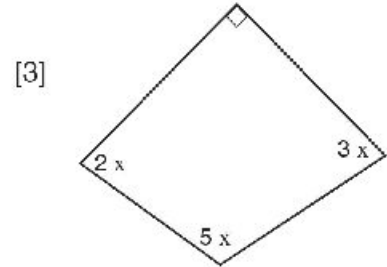
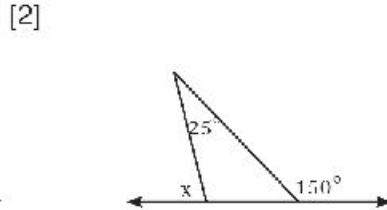
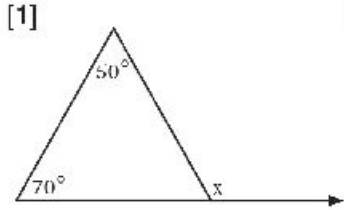

[b] The ratio between the measures of the angles of a quadrilateral is 2: 3: 3: 4. Calculate the measure of the smallest angle.

[c] A polygon has 15 sides.

- 1) Calculate the sum of the measures of its interior angles.
- 2) If the sum of the measures of five of its exterior angles is  $200^\circ$ , calculate the sum of the measures of the ten interior angles which are not adjacent to the five exterior angles.

**7** In The figure opposite,

D is the mid-point of  $\overline{AB}$ ,

E is the mid-point of  $\overline{AC}$ ,

$\overline{DF} \cap \overline{BC} = \{X\}$ ,  $DX = XF$

and  $BC = 12$  cm

Find the length of  $\overline{XY}$

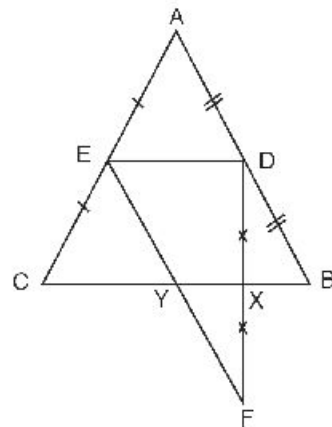

**8** Copy each figure on a graph paper. Draw their image under the transformations indicated. Give the coordinates of the images' vertices in each case.

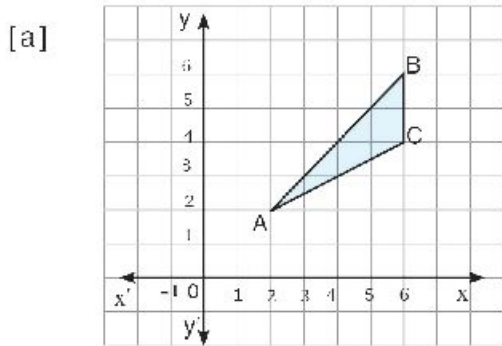

Reflection in the  $x - \text{axis}$

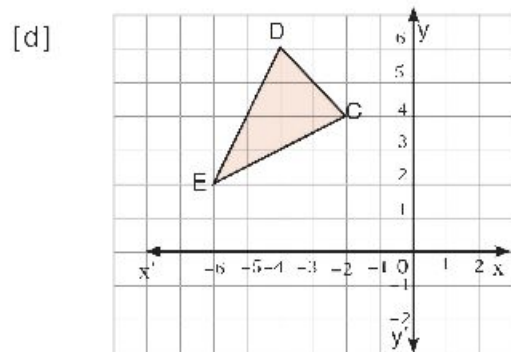

Rotation of  $90^\circ$  clockwise about O.

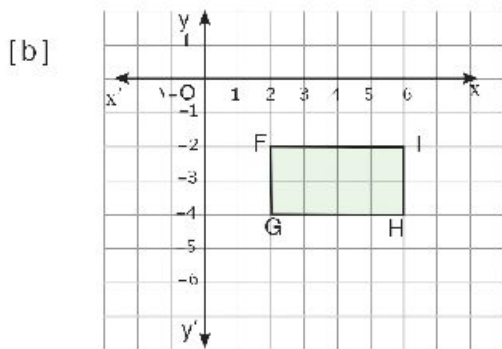

Reflection in  $\overleftrightarrow{FG}$

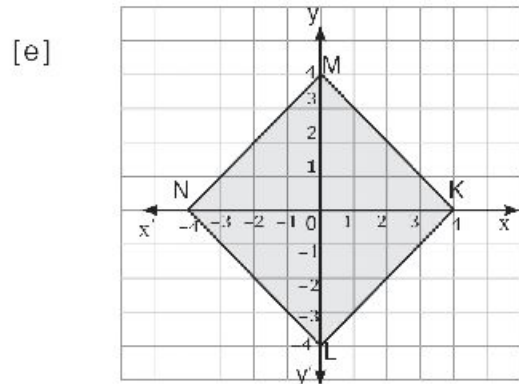

Rotation of  $90^\circ$  anticlockwise about O.

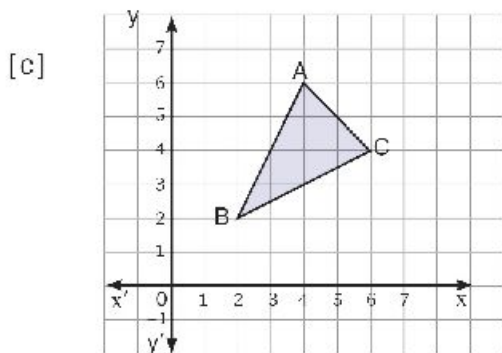

Translation:  $(x, y) \longrightarrow (x + 2, y + 3)$

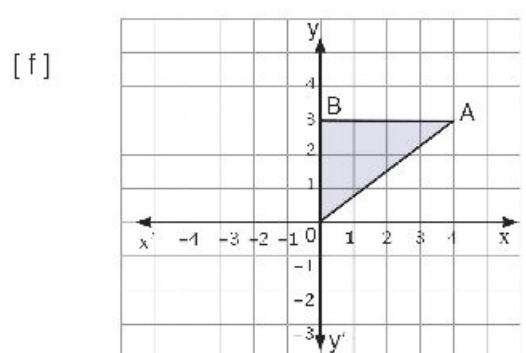

Translation: AO in direction of  $\overrightarrow{AO}$

## Model Exams Algebra

### Model (1)

#### 1 Complete:

[1]  $\frac{81}{625} = \left(\frac{25}{9}\right)^{\dots\dots\dots}$

[2] If  $7 - 2x = 3$ , then  $x = \dots\dots\dots$ ,  $x \in \mathbb{N}$

[3]  $3^{-1} + 4^{-1} = \dots\dots\dots$

[4] The standard form of the number  $0.7 \times 0.005 = \dots\dots\dots$

[5] The Probability of the certain event =  $\dots\dots\dots$

#### 2 Choose the correct answer :

[1] The sum of the probabilities for all possible outcomes of a randomly experiment is  $\dots\dots\dots$

- (a) zero                      (b) 1                      (c)  $> 1$                       (d)  $< 1$

[2] If  $3a = \sqrt{4} b$ , then  $\frac{a}{b} = \dots\dots\dots$

- (a) 2 : 3                      (b) 3 : 2                      (c) 3 : 4                      (d) 4 : 3

[3]  $\left(\frac{-2}{3}\right)^{-3}$  equals  $\dots\dots\dots$

- (a)  $\frac{-27}{8}$                       (b)  $\frac{-8}{27}$                       (c)  $\frac{8}{27}$                       (d)  $\frac{27}{8}$

[4] There are 21 boys and 15 girls in a classroom, one pupil is chosen randomly, the probability that the chosen pupil is a girl =  $\dots\dots\dots$

- (a)  $\frac{5}{12}$                       (b)  $\frac{7}{12}$                       (c)  $\frac{4}{7}$                       (d)  $\frac{5}{6}$

[5]  $\sqrt{(-8)^2 + (-6)^2} = \dots\dots\dots$

- (a)  $| -10 |$                       (b)  $\pm 10$                       (c) 14                      (d) -14

[6] 10% of L.E 2  $\frac{1}{2} = \dots\dots\dots$  L.E

- (a)  $\frac{1}{4}$                       (b)  $\frac{1}{2}$                       (c) 1                      (d) 25



**3 Simplify to the simplest form:**

(a)  $\left(-\frac{3}{7}\right)^0 \times \left(\frac{-2}{5}\right)^2 \times \sqrt{6\frac{1}{4}}$

(b) Find the numerical value of the expression

$3ab + 8a + 4b$  when  $a = 4$ ,  $b = -2$

**4** (a) Find in Q the s.s. of :  $3x + 1 = 25$

(b) Find the value of:  $\frac{8 \times 8^{-3}}{8^{-4}}$

**5** (a) A factory of a tire record the distance that traveled by a certain type of them before damage for 800 units of this type as following:

<b>The distance in thousand km</b>	Less than 50	50 to 100	More than 100 till 150	More than 150
<b>The number of damage tire</b>	80	120	280	320

If you bought the type of this tyre, what is the probability of change it :

\* **First** : before traveled 50 thousand km.

\* **Second** : After traveled more than 100 thousand km.

(b) Find in Q the s.s. of :  $2x + 5 < 16$

**Model (2)**

**1 Complete:**

[1]  $\left(\frac{-2}{3}\right)^0 = \dots\dots\dots$

[2]  $\sqrt{\frac{16}{49}} = \dots\dots\dots$

[3] The probability of impossible event =  $\dots\dots\dots$

[4] Complete in the same pattern 1 , 2 , 3 , 5 , 8  $\dots\dots$ ,  $\dots\dots$

[5] If the probability that the student is absent in a school is 0.15 , if the number of students of this school is 600 , then the number of the present student that day is  $\dots\dots\dots$

**2 Choose the correct answer :**

[1]  $2^3 \times 2^3 = \dots\dots\dots$

- (a)  $2^6$                       (b)  $2^9$                       (c)  $2^4$                       (d) 1

[2] Which of the following the greatest :

- (a)  $2.3 \times 10^4$               (b)  $2.3 \times 10^9$               (c)  $3.2 \times 10^4$               (d)  $3.2 \times 10^5$

[3]  $(x^2)^{-3} \times x^6 = \dots\dots\dots$

- (a)  $x^{12}$                       (b)  $x^{-12}$                       (c)  $x$                       (d) 1

[4] Which of the following may be probability of an event :

- (a)  $-0.35$                       (b) 87%                      (c) 1.05                      (d) 130%

[5] If  $-x > 4$ , then :

- (a)  $x > -4$                       (b)  $x > 4$                       (c)  $x < -4$                       (d)  $x < 4$

[6] Area of rectangle of length 120 cm , width 80 cm =  $\dots\dots\dots$  m<sup>2</sup>

- (a) 9600                      (b) 400                      (c) 9.6                      (d) 0.96

**3** (a) Two integers number the smaller one is  $2x$  and the greater is  $5x$  , if the difference between them is 30 find the two numbers.

(b) Find the value of  $\frac{5^{-1} \times 5^7}{5^3}$  in the simplest form.

**4** (a) Find in Q the s.s. of each of the following :

- i)  $(3x + 2) + 5 = 13$                       ii)  $2x + 15 < 19$

(b) Find the value of the expression in simplest form:

$$\left(\frac{-1}{3}\right)^2 + \sqrt{\frac{64}{81}} - \left(\frac{3}{7}\right)^0$$

**5** (a) If a regular die is thrown once and observed the number on upper face , find the probability of each of the following:

- i)** getting prime even number.  
**ii)** getting odd number less than 4.

(b) If  $x = \frac{-1}{2}$  ,  $y = \frac{-3}{4}$  , Find in the Simplest form of  $\left(\frac{y}{x^2}\right)^{-2}$



**Model Exam**  
(طلاب الدمج)

**1 Choose the correct answer :**

(a)  $\left(\frac{-2}{3}\right)^2 = \dots$                        $\left[\frac{4}{9}, \frac{-4}{9}, \frac{4}{6}, \frac{-4}{6}\right]$

(b)  $\left(\frac{4}{7}\right)^0 = \dots$                        $\left[0, 1, \frac{4}{7}, -1\right]$

(c)  $2 \times 6 - 4 \times 2 = \dots$                        $[4, 8, 10, 2]$

(d)  $(7)^{-2} = \dots$                        $\left[49, \frac{1}{49}, 14, -14\right]$

(e)  $\sqrt{9 + 16} = \dots$                        $[7, 5, 25, -7]$

**2 Complete each of the Following:**

(a) If  $x + 2 = 6$  , then  $x = \dots$

(b) when tossing a coin once , then the probability of the appearance of a tail is ....

(c) The probability of the impossible event = ....

(d)  $\sqrt{\left(\frac{2}{5}\right)^2} = \dots$

(e)  $7(6^2 - 5 \times 6) = \dots$

**3 Complete the solution to find the result :**

(a)  $12 \times 2^2 \div 24 + 3^2$   
 $= 12 \times \dots \div 24 + \dots$   
 $= \dots \div 24 + \dots$   
 $= \dots + \dots = \dots$

(b)  $\frac{8 + 20 - 4}{8 - 4} = \frac{\dots - 4}{\dots}$   
 $= \frac{\dots}{\dots} = \dots$

**4 Put (✓) or (X) :**

(a)  $2x + 3 = 7$ , then  $x = 2$  ( )

(b)  $\left(\frac{2}{3}\right)^2 \times \left(\frac{2}{3}\right)^5 = \left(\frac{2}{3}\right)^6$  ( )

(c)  $(X^2)^3 = X^6$  ( )

(d)  $\left(\frac{3}{2}\right)^2 = -\frac{9}{4}$  ( )

(e)  $\sqrt{100 - 64} = 2$  ( )





- 5** A Card is drawn randomly from 8 Cards numbered from 1 to 8 , join from column A to column B

( A )

( B )

- (1) The event of getting an even number = ..... ●
- (2) The probability of getting an even number = ..... ●
- (3) The event of getting a number  $> 6$  ●
- (4) The probability of getting a number  $< 9$  ●
- (5) The probability of getting a number 8 ●

- $\frac{1}{2}$
- $\{8, 6, 4, 2\}$
- 1
- $\frac{1}{8}$
- $\{8, 7\}$

## Model Exams Geometry

### Model (1)

Answer the following questions:

**1** Choose the correct answer:

- [1] Circumference of a circle of radius 7 cm = ..... cm  $(\pi = \frac{22}{7})$   
 (a) 11                      (b) 22                      (c) 44                      (d) 88
- [2] The image of the point  $(-1, 3)$  by translation  $(4, -2)$  is ...  
 (a)  $(3, 1)$                 (b)  $(3, -1)$                 (c)  $(5, 1)$                 (d)  $(5, -5)$
- [3] The measure of the exterior angle of the equilateral triangle is.....  
 (a)  $30^\circ$                       (b)  $45^\circ$                       (c)  $60^\circ$                       (d)  $120^\circ$
- [4] In a parallelogram if the two adjacent sides are equal in the length, then the shape is.....  
 (a) square                      (b) rhombus                      (c) rectangle                      (d) trapezium
- [5] The number of the diagonals of a pentagon is .....  
 (a) 3                              (b) 5                              (c) 7                              (d) 9
- [6] The number of axes of symmetry of an isosceles triangle =.....  
 (a) zero                              (b) 1                              (c) 2                              (d) 3

**2** Complete:

[1] The image of the point  $(2, 1)$  by reflection in X-axis is.....

[2] In the opposite figure:

$x = \dots\dots\dots^\circ$

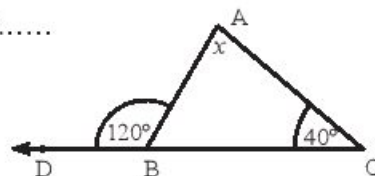

[3]  $\triangle XYZ$ , in which  $m(\angle Y) = 90^\circ$ ,  $XY = 3$  cm,  $XZ = 5$  cm,

Then  $YZ = \dots\dots\dots$  cm

(4) ABCD is a parallelogram in which  $m(\angle A) = 100^\circ$ ,

then  $m(\angle B) + m(\angle D) = \dots\dots\dots^\circ$

(5) The Sum of the measures of the interior angles of a triangle = ..... $^\circ$



**3 (a) In the opposite figure:**

$$m(\angle A) = m(\angle B) = 25^\circ$$

find  $m(\angle ACD)$

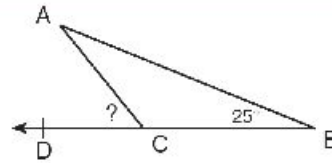

**(b) Draw a triangle ABC in which  $AB = 5$  cm ,  
 $AC = 3$  cm ,  $m(\angle A) = 40^\circ$  then draw  $C'$  in the image of C under rotation  
 $R(A, 40^\circ)$ ,  $B'$  in the image of B under rotation  $R(A, -40^\circ)$**

**4 (a) In the figure opposite,**

$$\overline{AB} \parallel \overline{DC} \quad , \quad \overline{AC} \cap \overline{BD} = \{M\}$$

$$m(\angle DAC) = 30^\circ \quad , \quad m(\angle DBC) = 40^\circ$$

$$\text{and } m(\angle AMB) = 70^\circ$$

Prove that: ABCD is a parallelogram

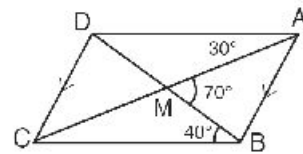

**(b) Use the translation**

$$(X, Y) \longrightarrow (X+2, Y+3) . \text{ Find the point whose image } (2, 3) .$$

**5 (a) In the opposite figure:**

$$\overline{AD} \perp \overline{BC} \text{ If } AD = 24 \text{ cm , } AB = 26 \text{ cm ,}$$

$$AC = 30 \text{ cm , Find the length of } \overline{BC} \text{ then}$$

Find the area of  $\triangle ABC$ .

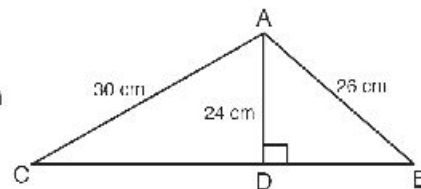

**(b) ABCD is a square ,  $E \in \overline{BC}$**

$$\overline{AC} \parallel \overline{DE} \quad , \text{ Prove that}$$

ACED is a parallelogram.

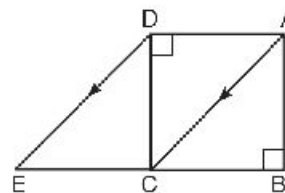

## Model (2)

**Answer the following questions**

**1 Choose the correct answer:**

[1]  $\Delta ABC$  is a right angled at B,  $AB = 6$  cm,  $BC = 8$  cm, then  $AC = \dots\dots\dots$  cm

- (a) 10                      (b) 28                      (c) 100                      (d) 160

[2] The measure of each angle of regular hexagon equals .....

- (a)  $60^\circ$                       (b)  $108^\circ$                       (c)  $120^\circ$                       (d)  $135^\circ$

[3] The two diagonals are equal in the length and not perpendicular in .....

- (a) parallelogram                      (b) rectangle                      (c) rhombus                      (d) square

[4] All the following shapes  $m(\angle X) = 60^\circ$  except the shape .....

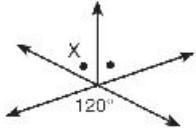
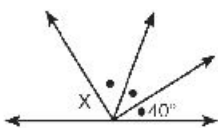
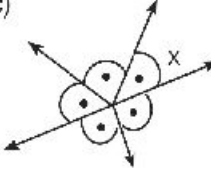
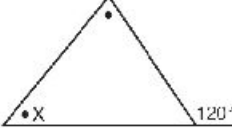
- (a)                       (b)                       (c)                       (d) 

**[5] In the opposite figure:**

The area of shaded part from the area of all shape equal

- (a)  $\frac{1}{8}$                       (b)  $\frac{1}{4}$                       (c)  $\frac{3}{8}$                       (d)  $\frac{3}{4}$

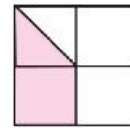

**[6] In the opposite figure,**

$m(\angle BDC) = \dots\dots\dots^\circ$

- (a) 60                      (b) 80                      (c) 100                      (d) 140

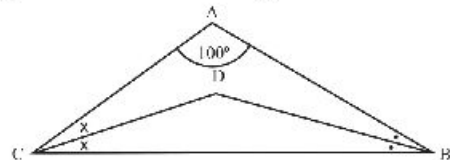

**2 Complete:**

[1] The Perimeter of the opposite figure, semi circle of diameter 14 cm and two semi-circles the diameter of each 7cm equals.....cm



[2] The image of the point  $(2, 3)$  by translation  $MN$ , in direction  $\vec{MN}$ , where  $M(2, -1)$ ,  $N(5, 1)$  is .....

[3] The volume of a cube of side length 1.2 m = .....  $\text{cm}^3$

**3 (a) In the opposite figure :**

XYZL is quadrilateral in which  
 $m(\angle Y) = m(\angle L) = 90^\circ$ ,  $XY = 7 \text{ cm}$ ,  
 $YZ = 24 \text{ cm}$ ,  $XL = 15 \text{ cm}$ . Find  
 The length of each of  $\overline{XZ}$ ,  $\overline{LZ}$

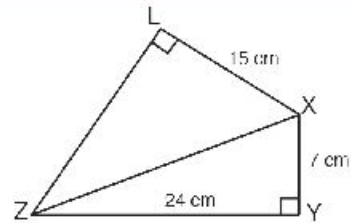

**(b)** Using the square lattice, draw  $\overline{AB}$  where  $A(4, 3)$ ,  $B(-1, 1)$  then find the image of  $\overline{AB}$  by translation  $(x, y) \rightarrow (x + 2, y - 1)$

**4 (a)** draw the image of triangle ABC where  $A(1, 1)$ ,  
 $B(3, 4)$ ,  $C(5, 2)$  by reflection in X-axis.

**(b) In the opposite figure:**

$\overline{AB}$ ,  $\overline{ED}$  are perpendicular to  
 $\overline{BD}$ ,  $\overline{BD} \cap \overline{AO} = \{C\}$   $m(\angle A) = 30^\circ$   
 $m(\angle EOC) = 120^\circ$ . Find  $m(\angle E)$

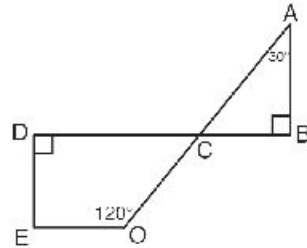

**5 (a) In the opposite figure:**

$\overline{EO} \parallel \overline{CD}$ ,  $m(\angle E) = 50^\circ$   
 $m(\angle C) = 30^\circ$ , Find the measures of  
 Angles of  $\triangle ABC$ ,  $m(\angle ABD)$

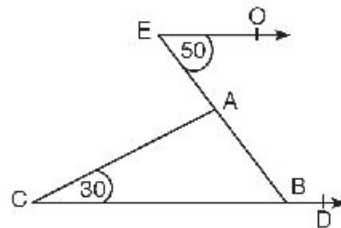

**(b) In the opposite figure:**

X is the midpoint of  $\overline{AB}$   
 $Y \in \overline{CD}$ ,  $Z \in \overline{CE}$   
 $\overline{AD} \parallel \overline{XY} \parallel \overline{BC}$   
 $\overline{YZ} \parallel \overline{DE}$   
 Is  $CZ = ZE$ ? giving reason.

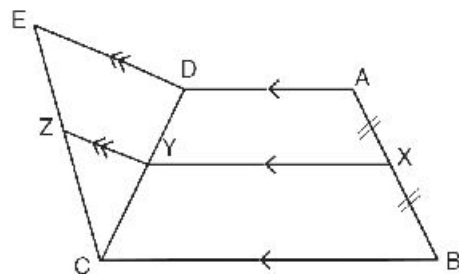

## Model Exam (طلاب الدمج)

Answer the following questions :

**1** Choose the correct answer :

(a) The Sum of the measures of the interior angles of a triangle = .....°

[ 90 , 360 , 180 , 540 ]

(b) The image of the point ( 3 , - 2 ) by reflection in the y- axis is the point .....

[ ( 3 , 2 ) , ( -3 , -2 ) , ( -3 , 2 ) , ( -2 , 3 ) ]

(c) The diagonals are equal and perpendicular in .....

[ rhombus , Square , rectangle , parallelogram ]

(d) In the opposite figure :

AC = .... cm

[ 5 , 7 , 25 , 625 ]

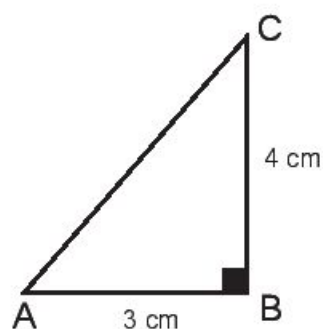

(e) In the opposite figure :

$m(\angle ACD) = \dots\dots^\circ$

[ 40 , 140 , 90 , 50 ]

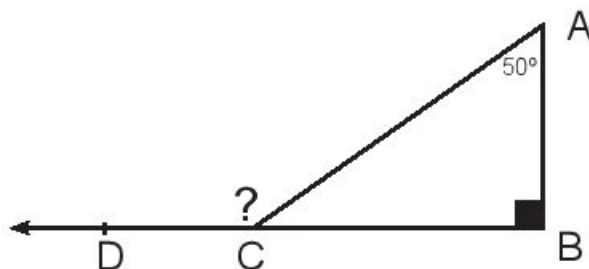

## 2 Complete each of the Following:

- (a) The length of the line segment that joins two mid points of two sides of a triangle = ..... the length of the third side.
- (b) The rectangle is a parallelogram in which one of it's angles is .....
- (c) The length of the side of a rhombus whose perimeter is 24 cm = ..... cm
- (d) The image of the point A ( -3 , 2 ) by reflection in the origin point is the point ( .... , .... )

- (e) In the opposite figure :

$X = \dots\dots\dots^\circ$

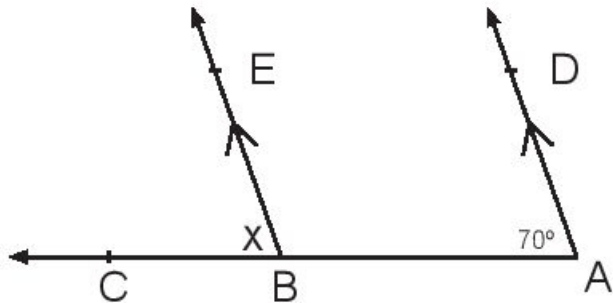

## 3 Put (✓) or (X) :

- (a) The image of the point ( 4 , 3 ) by reflection in the x-axis is the point ( 3 , -4 ) ( )
- (b) If ABC is a right-angled triangle at B , then  $(AB)^2 = (BC)^2 + (AC)^2$  ( )
- (c) The Pentagon has 5 diagonals ( )
- (d) ABCD is a parallelogram , in which  $m(\angle A) = 70^\circ$  , then  $m(\angle C) = 110^\circ$  ( )
- (e) Any triangle contains at least two acute angles ( )

**4** Join from the column ( A ) to the suitable in the column ( B )

( A )

( B )

- (1) The sum of the measures of the interior angles of a quadrilateral = ..... ●
- (2) The measure of each angle of a regular hexagon = ..... ●
- (3) The image of the point ( 3 , 2 ) by translation ( 1 , -2 ) is the point ..... ●
- (4) The image of the point ( 1 , 3 ) by rotation a bout the origin point , of angle  $180^\circ$  is the point ( .... , .... ) ●
- (5) The diagonal of the square divides the right vertex in to two angles , the measure of each = .....  $^\circ$  ●

- $120^\circ$
- $360^\circ$
- ( -1 , -3 )
- 45
- ( 4 , 0 )

**5** Find the value of x :

