



Arab Republic of Egypt
Ministry of Education
& Technical Education
Central Administration
of Book Affairs

Mathematics

For
First preparatory grade
first term

Author
Gamal Fathy Abdel-Sattar

Revised by
Mr/ Samir Mohamed Sedawy

counsellor of Mathematics
Mr/Gamal El -Shahed

2021 - 2022

غير مصرح بتداول هذا الكتاب خارج
وزارة التربية والتعليم والتعليم الفني

Introduction

It gives us pleasure to introduce this book to our students of the first form preparatory, hoping that it will fulfill what we aimed for in regards of simplicity of the information included and clarity. We hope it helps train our generations to be able to think scientifically and be innovative.

The aspirations of the human have exceeded the limits of Earth and reached out into Outer Space. Every day and night, satellites and information networks report on current events from all over the world.

Due to technological progress, learning sources have become plentiful and various, and learning medias have also become numerous and more various than before. This has also caused teaching aids to become more complex, valuable and of greater impact.

While composing this book, the following was taken into consideration :

- Since studying number has not been enough for solving various life problems, so we must start studying mathematics that uses symbols instead of numbers to solve such problems.
- The use of images, shapes and colors to clarify mathematical concepts and properties of shapes.
- Integrating and linking between mathematics and other subjects.
- Designing educational situations that facilitate the use of active learning strategies and problem - solving skills.
- Display lessons in a way that allows students to deduce and construe information on their own.
- The book includes real-life issues, educational activities and situations related to problems environment, health, population issues in addition to the development of values such as human rights, equality, justice and developing concepts of Patriotism.
- Giving a variety of evaluation exercises at the end of each lesson, a test at the end of each unit and examinations at the end of the book.
- Include Activity models to implement the Overall (Comprehensive) Educational Assessment
- Employ technological methods.

This book has included four units:

Unit 1: Numbers - It aims at presenting the characteristics of numbers, representation of computational processes and understanding the relationships between them.

Unit 2: Algebra - It presents the meaning of algebraic terms and expressions and operations on them.

Unit 3: Geometry and measurement - It focuses on drawing 2 and 3 dimensional (shapes and solids) and being able to identify their properties and analyze the relations between them.

Unit 4: statistics - It aims at acknowledging data collection, organization and presentation as a way of finding a response to certain queries and passing judgement on interpretations and predictions based on the analysis of certain data.

While explaining the topics included in this book, it was taken into consideration that it must be as simple as possible with a wide variety of exercises to provide the students with the opportunity to think and create.

The Author

List of symbols

There is a meaning for each mathematical symbol

Symbol	How read
$X = \{\dots\dots, \dots\dots, \dots\dots\}$	X is the set whose elements are
\emptyset or $\{ \}$	empty set or null set
\in	is an element of or belongs to
\notin	is not an element of or does not belong to
\subset	is a subset of or is contained in
$\not\subset$	is not a subset of or is not contained in
$X \cap Y = \{ a : a \in X \text{ and } a \in Y \}$	Intersection of two sets X and Y is the set which contains all the elements belonging to X and Y.
$X \cup Y = \{ a : a \in X \text{ or } a \in Y \}$	Union of two sets X and Y is that set which contains all the elements belonging to X or Y.
\mathbb{N}	Set of Natural numbers $\{ 0, 1, 2, \dots \}$
\mathbb{Z}	Integers $\{\dots, -2, -1, 0, 1, 2, \dots\}$
\mathbb{Z}^+	Set of positive integers $\{ 1, 2, 3, \dots \}$
\mathbb{Z}^-	Set of negative Integers $\{ -1, -2, -3, \dots \}$
\leq	is less than or equal to
\geq	is greater than or equal to

Symbol	How read
\neq	is not equal to
$ a $	absolute value of a
(a, b)	the ordered pair with first coordinate a and second coordinate b.
$a \times a \times \dots$ to n factors $= a^n$	the n^{th} power for the number a
\sqrt{a}	the square root of a
$//$	is parallel to
\perp	is perpendicular to
Δ	triangle
\because	Since
\therefore	Therefore
	right angle
\overline{AB}	Line segment AB
\overrightarrow{AB}	ray AB
$\longleftrightarrow AB$	Straight line AB
\angle	Angle
\cong	is congruent to

Contents

Unit 1: Numbers

Lesson 1 : set of rational numbers	2
Lesson 2 : Comparing and ordering rational numbers	6
Lesson 3 : Adding rational numbers	9
Lesson 4 : Properties of addition operation in the set of rational numbers	12
Lesson 5 : Subtraction of rational numbers	15
Lesson 6 : Multiplying of rational numbers	16
Lesson 7 : Properties of multiplication operation in the set of rational numbers	18
Lesson 8 : Division of rational numbers	21

Unit 2: Algebra

Lesson 1 : Algebraic terms and algebraic expressions	31
Lesson 2 : Like terms	33
Lesson 3 : Multiplying and dividing algebraic terms	35
Lesson 4 : Adding and subtracting algebraic expressions	39
Lesson 5 : Multiplying a monomial by an algebraic expression	41
Lesson 6 : Multiplying a binomial by an algebraic expression	43
Lesson 7 : Dividing algebraic expression by a monomial	49
Lesson 8 : Dividing algebraic expression by another	51
Lesson 9 : Factorization by taking out the H.C.F.	53

Unit 3: Statistics

Lesson 1 : Arithmetic Mean	64
Lesson 2 : Median	67
Lesson 3 : Mode	69

Unit 4: Geometry and Measurement

Lesson 1 : Geometrical concepts	81
Lesson 2 : Congruence	88
Lesson 3 : Congruent triangles	90
Lesson 4 : Parallelism	100
Lesson 5 : Geometric constructions	109

Examinations.

Muhamed Ibn Ahmed Abo Al Rihany Al Bairony

(363 H - 973 AD)

Al Bairony is one of the famous Arab Mathematicians. He stated that letters and digits vary in India by local variation and the Arabs took the best of what they have, then they refined some of them and formed two series known as:

★ Indian numbers

1, 2, 3, 4, 5, 6, 7, 8, 9, 0

and are used by Eastern Arab.

Andalusian numbers (El Ghobaria):

9, 8, 7, 6, 5, 4, 3, 2, 1, 0

and are used in Al Maghreb and Andalus.

**Contents****● Revision**

Lesson 1 : Set of rational numbers.

Lesson 2 : Comparing and ordering rational numbers.

Lesson 3 : Adding rational numbers.

Lesson 4 : Properties of addition operation in the set of rational numbers.

Lesson 5 : Subtraction of rational numbers.

Lesson 6 : Multiplying of rational numbers.

Lesson 7 : Properties of multiplication operation in the set of rational numbers.

Lesson 8 : Division of rational numbers.

● Mental Math.**● Miscellaneous Exercises****● unit test.**

We know
that

- $2 = \frac{2}{1} \longrightarrow \frac{a}{b}, 2 \in \mathbb{Z}$
- $0 = \frac{0}{1} \longrightarrow \frac{a}{b}, 0 \in \mathbb{Z}$
- $-1 = -\frac{1}{1} \longrightarrow -\frac{a}{b}, -1 \in \mathbb{Z}$
- $-1\frac{3}{4} = -\frac{7}{4} \longrightarrow -\frac{a}{b}, -1\frac{3}{4} \notin \mathbb{Z}$
- $-1.25 = -\frac{5}{4} \longrightarrow -\frac{a}{b}, -1.25 \notin \mathbb{Z}$

A rational number is a number that can be expressed in the form $\frac{a}{b}$, where a and b are integers and $b \neq 0$.

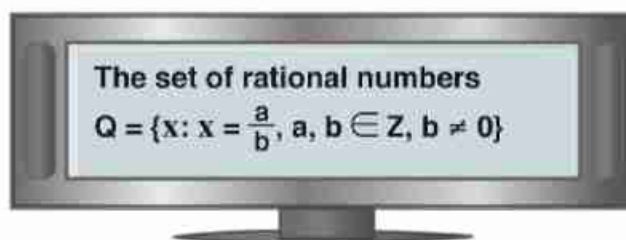

The set of Integers \mathbb{Z} is a subset of the set of the rational numbers \mathbb{Q} $\xrightarrow{\mathbb{Z} \subset \mathbb{Q}}$ \mathbb{Z} is a subset of \mathbb{Q}

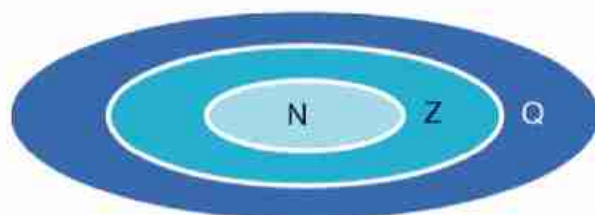

$$\mathbb{N} \subset \mathbb{Z} \subset \mathbb{Q}$$

The set of rational numbers can be represented on the number line.

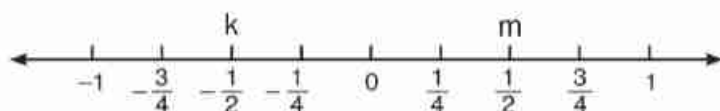

The point m is mid way between 0 and 1 represents the rational number $\frac{1}{2}$, and is read as positive half

The point k is mid way between 0 and -1 represents $-\frac{1}{2}$ and is read as "negative half"

Example (1)

Write the following numbers on the form $\frac{a}{b}$

[a] $|-9\frac{1}{3}|$. [b] 0.15. [c] 40%.

Solution:

$$[a] \quad |-9\frac{1}{3}| = 9\frac{1}{3} = \frac{28}{3}$$

$$[b] \quad 0.15 = \frac{15}{100} = \frac{3}{20}$$

$$[c] \quad 40\% = \frac{40}{100} = \frac{4}{10} = \frac{2}{5}$$

Example (2)

Write the following numbers on the decimal and percentage form.

[a] $\frac{16}{25}$. [b] $|-2\frac{1}{4}|$. [c] $\frac{25}{8}$.

Solution:

$$[a] \quad \frac{16}{25} = \frac{16 \times 4}{25 \times 4} = \frac{64}{100} = 0.64 = 64\%.$$

$$[b] \quad |-2\frac{1}{4}| = \frac{9}{4} = 2.25 = 225\%.$$

$$[c] \quad \frac{25}{8} = 3\frac{1}{8} = 3.125 = 312.5\%.$$

Different forms of a rational number

- Rational numbers such as $\frac{3}{4}$ and $\frac{7}{5}$ can be written as terminating decimals.

$$\frac{3}{4} = 0.75 = 0.750 = \dots \qquad \frac{7}{5} = \frac{14}{10} = 1.4 = 1.40 = \dots$$

- Rational numbers such as $\frac{3}{4}$ and $\frac{7}{5}$ can be written as percentages

$$\frac{3}{4} = \frac{3 \times 25}{4 \times 25} = \frac{75}{100} = 75\% \qquad \frac{7}{5} = \frac{7 \times 20}{5 \times 20} = \frac{140}{100} = 140\%$$

- Rational numbers such as $\frac{1}{3}$ and $\frac{2}{11}$ can be represented by an infinite repeating decimal.

$$\frac{1}{3} = 0.333 \dots = 0.\dot{3}$$

$$\frac{2}{11} = 0.1818 \dots = 0.1\dot{8}$$

The point above the digit means that it is a repeating digit



Exercise (1- 1)

- Use the number line to identify the opposite of each rational number in the table

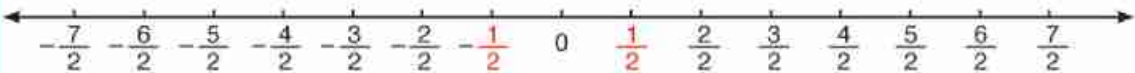

Rational number	$\frac{1}{2}$	$\frac{3}{2}$	$\frac{4}{2}$	$-\frac{5}{2}$	$\frac{7}{2}$	$-\frac{3}{2}$	$-\frac{7}{2}$	$\frac{2}{2}$	$-\frac{6}{2}$	$\frac{6}{2}$
Opposite	$-\frac{1}{2}$									

- Complete the rational numbers on the number lines.

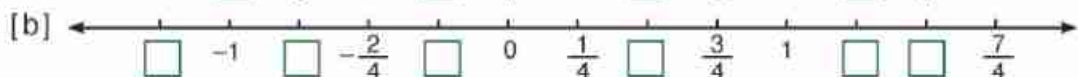
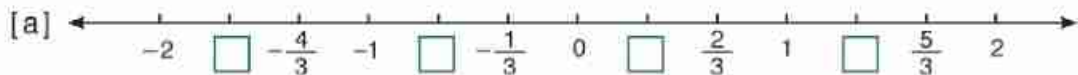

- 3** Use an arrow to represent each of the following numbers on the number line.

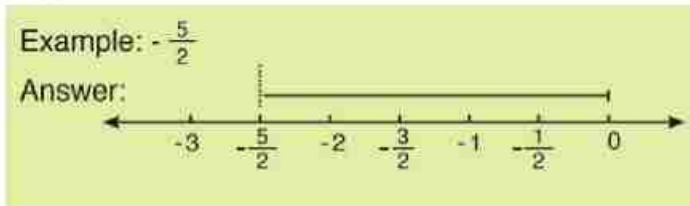

- [a] $\frac{1}{3}$ [b] $-\frac{1}{3}$ [c] $-\frac{4}{5}$
 [d] $-3\frac{1}{2}$ [e] $1\frac{1}{5}$

- 4** Classify each statement as true, **T**, or false, **F**, when a statement is false, tell why it is false.

- [a] $\frac{1}{3}$ is a natural number.
 [b] $-\frac{1}{3}$ is an integer.
 [c] $12\frac{5}{6}$ is a rational number.
 [d] 6.5 is a rational number.
 [e] The number 0 is neither positive nor negative.
 [f] The number 0 is a counting number.

- 5** [a] Why does the definition of a rational number $\frac{a}{b}$ state that $b \neq 0$?

[b] which rational number $\frac{7}{11}$ or $\frac{7}{20}$, can be written as a terminating decimal?

[c] write a decimal for each rational number: 1) $\frac{6}{11}$ 2) $-3\frac{1}{15}$

[d] Evaluate: $|-3\frac{1}{2}|$, $|\frac{5}{8}|$, $|-0.37|$, $|-0.2|$, $|-1\frac{1}{3}|$

- 6** Write the following numbers in the form $\frac{a}{b}$:

- [a] 0.4 [c] 30% [e] $8\frac{2}{3}$
 [b] 0.75 [d] zero [f] -0.01

- 7** Write the following rational numbers as a decimal and a percentage.

- [a] $\frac{1}{6}$ [b] $2\frac{1}{2}$
 [c] $7\frac{3}{16}$ [d] $-\frac{3}{20}$

Comparing and ordering Rational numbers

The number line

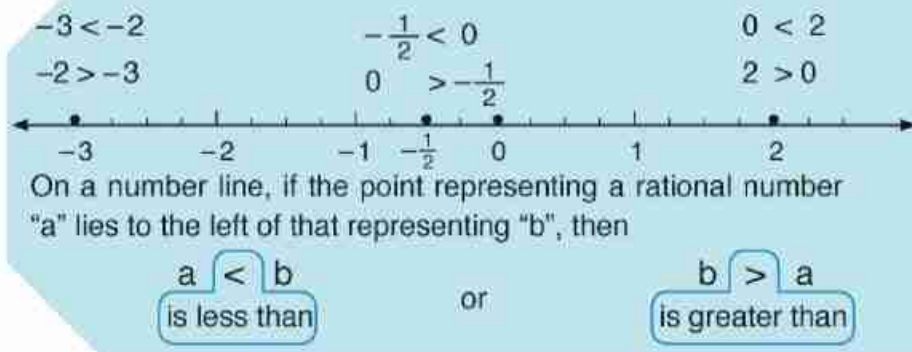

The ascending order of the rational numbers $-3, 0, 2, -\frac{1}{2}$ is $-3, -\frac{1}{2}, 0, 2$

The descending order of the rational numbers $-3, 0, 2, -\frac{1}{2}$ is $2, 0, -\frac{1}{2}, -3$

Example 1

Represent the rational numbers $3, -\frac{3}{2}, \frac{5}{2}, 0$ and -4 on a number line, then rewrite them in an ascending order.

Solution :

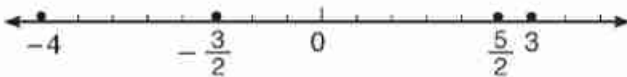

The order is : $-4, -\frac{3}{2}, 0, \frac{5}{2}, 3$

Example 2

Which rational number is greater $\frac{4}{7}$ or $\frac{3}{5}$?

Solution:

The L.C.M. of 7 and 5 is 35

$$\frac{4}{7} = \frac{4 \times 5}{7 \times 5} = \frac{20}{35}$$

$$\frac{3}{5} = \frac{3 \times 7}{5 \times 7} = \frac{21}{35}$$

Since $21 > 20$, $\frac{21}{35} > \frac{20}{35}$ then $\frac{3}{5} > \frac{4}{7}$

Example 3

Which rational number is greater $-\frac{2}{3}$ or $-\frac{3}{4}$?

Solution:

The L.C.M. of 3 and 4 is 12

$$-\frac{2}{3} = -\frac{2 \times 4}{3 \times 4} = -\frac{8}{12}$$

$$-\frac{3}{4} = -\frac{3 \times 3}{4 \times 3} = -\frac{9}{12}$$

since $-\frac{8}{12} > -\frac{9}{12}$, then $-\frac{2}{3} > -\frac{3}{4}$

Density of rational numbers

Example 4

Find three rational numbers between $\frac{4}{5}$ and $\frac{2}{3}$

Solution :

The L.C.M. for the denominators 5 and 3 equals 15

$$\left. \begin{array}{l} \frac{4}{5} = \frac{4 \times 3}{5 \times 3} = \frac{12}{15} \\ \frac{2}{3} = \frac{2 \times 5}{3 \times 5} = \frac{10}{15} \end{array} \right\} \longrightarrow \frac{11}{15} \text{ is a rational number existing between} \\ \text{the two rational numbers } \frac{4}{5} \text{ and } \frac{2}{3}$$

$$\text{because } \frac{10}{15} < \frac{11}{15} < \frac{12}{15}$$

To find three rational numbers between them, multiply the numerator and denominator of $\frac{12}{15}$ and $\frac{10}{15}$ by 2

$$\left. \begin{array}{l} \frac{12}{15} = \frac{12 \times 2}{15 \times 2} = \frac{24}{30} \\ \frac{10}{15} = \frac{10 \times 2}{15 \times 2} = \frac{20}{30} \end{array} \right\} \longrightarrow \text{The three required numbers are : } \frac{21}{30}, \frac{22}{30}, \frac{23}{30}$$

$$\text{Because } \frac{20}{30} < \frac{21}{30} < \frac{22}{30} < \frac{23}{30} < \frac{24}{30}$$

We can obtain an infinite number of rational numbers between $\frac{4}{5}$ and $\frac{2}{3}$

Deduction

Between any two different rational numbers there exists an infinite number of rational numbers, thus the rational numbers is dense.

Exercise (1- 2)

1 Write the correct sign (<, = ,>):

[a] $-\frac{1}{2}$ 0

[e] Every positive rational number 0

[b] $-\frac{3}{4}$ $\frac{1}{4}$

[f] Every negative rational number 0

[c] $-4\frac{1}{2}$ -5

[g] $|- \frac{3}{2}|$ $\frac{1}{2}$

[d] $4\frac{1}{2}$ 5

[h] $|\frac{15}{2}|$ $7\frac{1}{2}$

2 Represent each set of the following rational numbers on the number line, and rewrite its elements in an ascending order.

[a] {0, 1, -2, 3}

[c] $\{2\frac{1}{2}, \frac{1}{2}, -\frac{1}{4}, 1\}$

[b] $\{1\frac{1}{2}, -2\frac{1}{2}, 0, 2\frac{1}{2}\}$

[d] {-6.5, -4, -5, -3.5}

3 Which of the rational numbers is greater? Explain your answer.

[a] $\frac{4}{7}$ or $\frac{2}{3}$

[c] $-\frac{7}{6}$ or $-\frac{11}{15}$

[b] $\frac{5}{6}$ or $\frac{4}{5}$

[d] $-\frac{8}{3}$ or $-\frac{16}{7}$

4 Write the missing rational number.

[a] $\frac{2}{5} <$ $< \frac{3}{5}$

[c] $\frac{1}{8} <$ $< \frac{1}{4}$

[b] $-\frac{2}{3} <$ $< -\frac{1}{3}$

[d] $-\frac{2}{7} <$ $< -\frac{3}{14}$

5 Write the rational number that equals $\frac{3}{5}$, and the sum of its terms is 24

6 [a] Identify and write four rational numbers between $\frac{3}{2}$ and $\frac{3}{4}$, such that one of them is an integer and the other is a rational number.

[b] Identify and write four rational numbers between $\frac{-4}{9}$ and $\frac{-5}{6}$

Lesson 3

Addition of rational numbers

Represent the rational numbers on the number line will help you to add them.

Example

$$-\frac{5}{8} + \frac{3}{8}$$

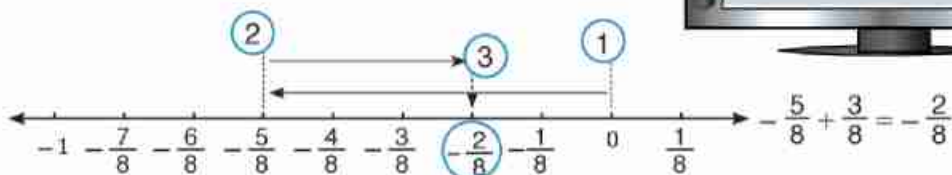

Follow the three steps

1, 2, 3 to find the sum

1 Complete

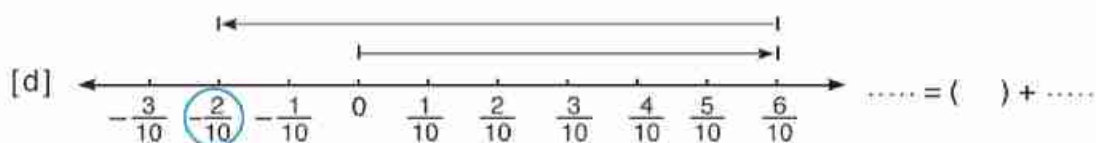
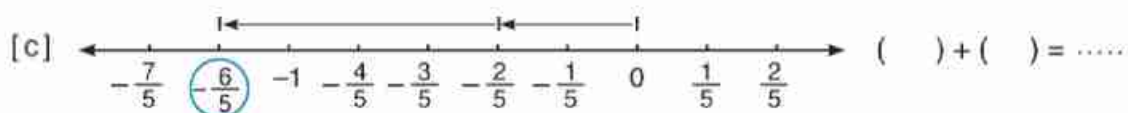
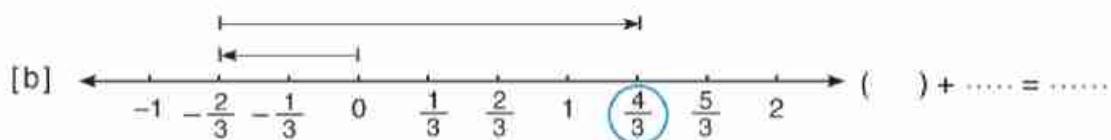
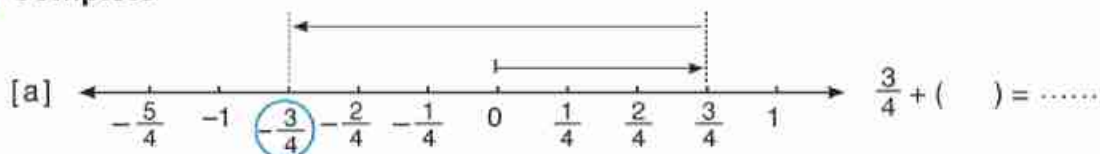

2 Use the number line to add the following rational numbers:

a) $\frac{5}{8} + (-\frac{3}{8})$

b) $-\frac{1}{3} + \frac{5}{3}$

c) $-\frac{3}{4} + (-\frac{1}{4})$

Example (2)

Find the value of each of the following in its simplest form:

[a] $-\frac{4}{5} + (-\frac{3}{2})$

[b] $3\frac{1}{4} + (-2\frac{1}{3})$

Solution:

[a] The L. C. M. of 5 and 2 is 10

$$\begin{aligned} -\frac{4}{5} + (-\frac{3}{2}) &= -\frac{4 \times 2}{5 \times 2} + (-\frac{3 \times 5}{2 \times 5}) \\ &= -\frac{8}{10} + (-\frac{15}{10}) \\ &= -\frac{23}{10} \end{aligned}$$

[b] The L. C. M. of 4 and 3 is 12

$$\begin{aligned} 3\frac{1}{4} + (-2\frac{1}{3}) &= 3\frac{1 \times 3}{4 \times 3} + (-2\frac{1 \times 4}{3 \times 4}) \\ &= 3\frac{3}{12} + (-2\frac{4}{12}) \\ &= 2\frac{15}{12} + (-2\frac{4}{12}) = \frac{11}{12} \end{aligned}$$

Example (3)

Find the value of each of the following in its simplest form:

[a] $1\frac{5}{8} + (-7\frac{3}{4})$

[b] $\frac{1}{5} + (-4\frac{1}{3})$

Solution:

[a] The L.C.M of 8, 4 is 8

$$\begin{aligned} 1\frac{5}{8} + (-7\frac{3}{4}) &= 1\frac{5}{8} + (-7\frac{2 \times 3}{2 \times 4}) \\ &= 1\frac{5}{8} + (-7\frac{6}{8}) \\ &= -6\frac{1}{8} \end{aligned}$$

[b] L.C.M of 5 and 3 is 15

$$\begin{aligned} \frac{1}{5} + (-4\frac{1}{3}) &= \frac{3 \times 1}{3 \times 5} + (-4\frac{5 \times 1}{3 \times 5}) \\ &= \frac{3}{15} + (-4\frac{5}{15}) \\ &= -4\frac{2}{15} \end{aligned}$$

Exercise (1-3)

- 1** State whether the result of the sum of the following rational numbers is positive, negative or zero:

[a] $-\frac{3}{4} + (-\frac{1}{4})$

[b] $\frac{6}{7} + (-\frac{3}{7})$

[c] $\frac{12}{2} + (-\frac{16}{4})$

[d] $\frac{4}{3} + (-\frac{4}{3})$

[e] $-\frac{1}{5} + \frac{3}{5}$

[f] $-\frac{10}{100} + (-\frac{1}{10})$

- 2** Find the value and express it in its simplest form:

[a] $-\frac{3}{10} + (-\frac{2}{5})$

[b] $\frac{1}{4} + \frac{25}{8}$

[c] $\frac{19}{10} + (-\frac{39}{100})$

[d] $-\frac{9}{12} + \frac{3}{16}$

- 3** Find the value and express it in its simplest form.
(Is the sum a rational number?)

[a] $8\frac{2}{3} + (-5\frac{1}{6})$

[b] $-15\frac{1}{2} + 2\frac{3}{8}$

[c] $\frac{1}{4} + 2\frac{3}{8}$

[d] $-8\frac{1}{3} + (-4\frac{1}{12})$

[e] $4 + (-9\frac{5}{8})$

[f] $-2 + 13\frac{3}{7}$

Properties of addition operation in the set of rational numbers

Complete

[a] $\frac{2}{3} + \frac{3}{4} = \dots$

Is the sum a rational number?

[b] $-\frac{3}{5} + \frac{2}{5} = \dots$,

Are the sums equal in each case?

$\frac{2}{5} + (-\frac{3}{5}) = \dots$

[c] $(-\frac{5}{3} + \frac{2}{3}) + \frac{1}{3} = () + \frac{1}{3} = \dots$,

Does addition of rational numbers have the grouping property?

$-\frac{5}{3} + (\frac{2}{3} + \frac{1}{3}) = -\frac{5}{3} + \dots = \dots$

[d] $-\frac{8}{3} + 0 = \dots$,

Does the value of a rational number change if you add to it zero?

$0 + (-\frac{4}{7}) = \dots$

[e] $\frac{9}{8} + (-\frac{9}{8}) = \dots$

What do you notice?

For every rational numbers $\frac{a}{b}$, $\frac{c}{d}$ and $\frac{e}{f}$ then:

The property	Description in symbols	Example
1 - Closure	$\frac{a}{b} + \frac{c}{d} = \frac{ad+bc}{bd} \in \mathbb{Q}$	If $\frac{1}{2}, 2 \in \mathbb{Q}$ then $\frac{1}{2} + 2 = \dots \in \mathbb{Q}$
2 - Commutative	$\frac{a}{b} + \frac{c}{d} = \frac{c}{d} + \frac{a}{b}$	
3 - Associative	$(\frac{a}{b} + \frac{c}{d}) + \frac{e}{f} = \frac{a}{b} + (\frac{c}{d} + \frac{e}{f})$ $= \frac{a}{b} + \frac{c}{d} + \frac{e}{f}$	
4 - Additive-identity	$\frac{a}{b} + 0 = 0 + \frac{a}{b} = \frac{a}{b}$	
5 - Additive-Inverse	For every $\frac{a}{b}$, there exists the additive inverse $-\frac{a}{b}$ Where $\frac{a}{b} + (-\frac{a}{b}) = 0$	

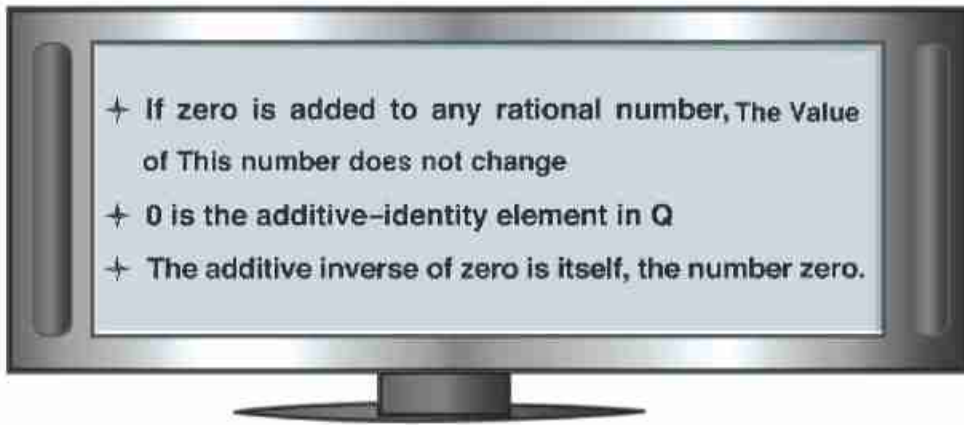

Example (1)

Find the value of each of the following, stating the property:

$$[a] \frac{5}{10} + \left(\frac{-7}{10}\right), \quad \left(\frac{-7}{10}\right) + \frac{5}{10}$$

$$[b] \left(\frac{1}{8} + \frac{3}{8}\right) + \frac{2}{8}, \quad \frac{1}{8} + \left(\frac{3}{8} + \frac{2}{8}\right)$$

$$[c] \frac{4}{5} + \left(\frac{-4}{5}\right), \quad \frac{-5}{12} + \frac{5}{12}$$

Solution:

$$[a] \frac{5}{10} + \left(\frac{-7}{10}\right) = \frac{-2}{10}$$

$$\left(\frac{-7}{10}\right) + \frac{5}{10} = \frac{-2}{10}$$

$$\therefore \frac{5}{10} + \left(\frac{-7}{10}\right) = \left(\frac{-7}{10}\right) + \frac{5}{10} + \frac{-2}{10}$$

Commutative property

$$[b] \left(\frac{1}{8} + \frac{3}{8}\right) + \frac{2}{8} = \frac{4}{8} + \frac{2}{8} = \frac{6}{8} = \frac{3}{4}$$

$$\frac{1}{8} + \left(\frac{3}{8} + \frac{2}{8}\right) = \frac{1}{8} + \frac{5}{8} = \frac{6}{8} = \frac{3}{4}$$

$$\therefore \left(\frac{1}{8} + \frac{3}{8}\right) + \frac{2}{8} = \frac{1}{8} + \left(\frac{3}{8} + \frac{2}{8}\right) = \frac{3}{4}$$

Associative property

$$[c] \frac{4}{5} + \left(\frac{-4}{5}\right) = \frac{4-4}{5} = \text{Zero}$$

$$\frac{-5}{12} + \frac{5}{12} = \frac{-5+5}{12} = \text{Zero}$$

Additive inverse property

Exercise (1- 4)

1 Write the property of addition operation used in each of the following:

$$[a] \frac{7}{2} + \frac{9}{16} = \frac{9}{16} + \frac{7}{2}$$

$$[b] \left[\frac{2}{3} + \left(-\frac{1}{3}\right) \right] + \left(-\frac{1}{6}\right) = \frac{2}{3} + \left[-\frac{1}{3} + \left(-\frac{1}{6}\right) \right]$$

$$[c] \frac{3}{4} + \left(-\frac{3}{4}\right) = 0$$

$$[d] \frac{5}{8} + 0 = \left(\frac{5}{8}\right)$$

2 Find the sum of each of the following:

$$[a] \frac{4}{7} + 0$$

$$[d] \frac{5}{6} + \left(-\frac{3}{6} + \frac{3}{6}\right)$$

$$[b] 0 + \left(-\frac{7}{10}\right)$$

$$[c] \left[\frac{1}{4} + \left(-\frac{1}{4}\right) \right] + \frac{3}{4}$$

$$[e] \left[\frac{2}{9} + \left(-\frac{4}{9}\right) \right] + \left(-\frac{3}{9}\right)$$

3 Write the additive inverse of each of the following rational number:

$$[a] \frac{3}{7}$$

$$[c] \text{zero}$$

$$[e] -2.3$$

$$[b] -\frac{4}{9}$$

$$[d] -6$$

$$[f] 5.41$$

Mental Math

4 Complete

$$[a] 14\frac{1}{2} + \left(-11\frac{1}{2}\right) = \dots + \left[11\frac{1}{2} + \left(-11\frac{1}{2}\right) \right]$$

$$[b] \frac{3}{32} + \left(-\frac{17}{32}\right) = \left[\frac{3}{32} + \left(-\frac{3}{32}\right) \right] + \dots$$

5 Find the sum in simplest form by using the properties of addition operation in Q:

$$[a] 7\frac{1}{4} + \left(-11\frac{1}{4}\right)$$

$$[b] \frac{2}{3} + \frac{4}{5} + \frac{3}{4}$$

$$[c] -13\frac{1}{8} + 7\frac{3}{8}$$

Lesson 5

Subtraction of rational numbers

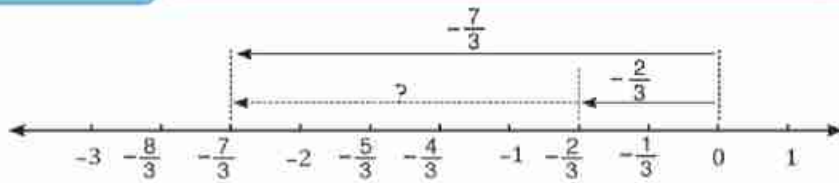

$$-\frac{2}{3} + \dots = -\frac{7}{3}$$

$$-\frac{2}{3} + \left(-\frac{5}{3}\right) = -\frac{7}{3}$$

The subtraction operation $\left(\frac{a}{b} - \frac{c}{d}\right)$ is an addition operation of the minuend $\frac{a}{b}$ with the additive inverse of the subtrahend $\frac{c}{d}$:

$$\frac{a}{b} - \frac{c}{d} = \frac{a}{b} + \left(-\frac{c}{d}\right)$$

Example

Calculate the value of each of the following in its simplest form:

[a] $\frac{9}{2} - \frac{13}{4}$

[b] $-3\frac{2}{3} - 2\frac{5}{6}$

Solution:

[a] L.C.M. of 2 and 4 is 4

[b] L.C.M. of 3 and 6 is 6

$$\begin{aligned}\frac{9}{2} - \frac{13}{4} &= \frac{9 \times 2}{2 \times 2} + \left(-\frac{13}{4}\right) \\ &= \frac{18}{4} + \left(-\frac{13}{4}\right) \\ &= \frac{5}{4}\end{aligned}$$

$$\begin{aligned}-3\frac{2}{3} - 2\frac{5}{6} &= -3\frac{2 \times 2}{3 \times 2} + \left(-2\frac{5}{6}\right) \\ &= -3\frac{4}{6} + \left(-2\frac{5}{6}\right) \\ &= -5\frac{9}{6} = -5\frac{3}{2} = -6\frac{1}{2}\end{aligned}$$

Exercise (1-5)

1 Put for the correct statement and for the incorrect one:

[a] $\frac{9}{16} - \left(-\frac{3}{4}\right) = \frac{9}{16} + \left(-\frac{3}{4}\right)$

[c] $0 - \left(-\frac{13}{5}\right) = \frac{13}{5}$

[b] $-3\frac{1}{6} - \left(-7\frac{1}{12}\right) = -3\frac{1}{6} + 7\frac{1}{12}$

[d] $-\frac{3}{4} - \frac{2}{5} = -\frac{3}{4} + \frac{2}{5}$

2 Calculate the value of each of the following in its simplest form:

[a] $1\frac{3}{4} - \left(-2\frac{1}{2}\right)$

[c] $0 - \left(-\frac{17}{4}\right)$

[e] $-\frac{3}{5} - \frac{9}{5}$

[b] $-10\frac{7}{8} - \left(-4\frac{5}{8}\right)$

[d] $6\frac{2}{3} - 3\frac{1}{6}$

[f] $-2\frac{1}{2} - 12\frac{1}{16}$

The product
of two rational
numbers

To multiply two rational numbers we must multiply their numerators to get the numerator of the product. Then multiply their denominators to get the denominator of the product.

$$\frac{2}{5} \times \frac{4}{3} = \frac{2 \times 4}{5 \times 3} = \frac{\dots}{\dots} \quad -\frac{2}{3} \times \frac{6}{7} = -\frac{2 \times 6}{3 \times 7} = \frac{\dots}{\dots}$$

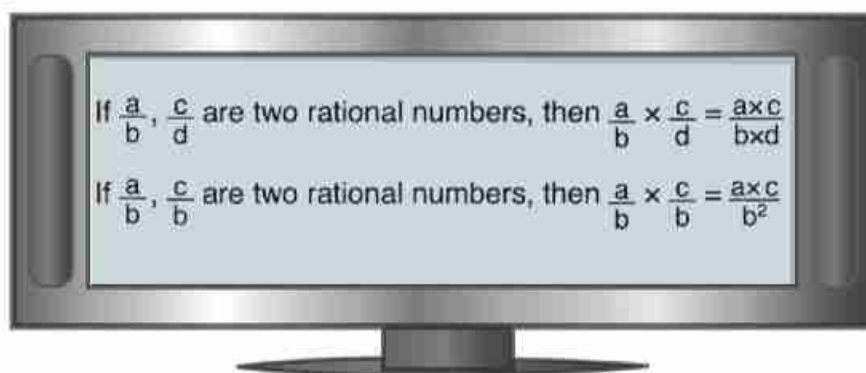

Example (1)

Find the result of each of the following

[a] $\frac{2}{5} \times \frac{4}{3}$

[b] $\frac{3}{7} \times \frac{-4}{5}$

[c] $\frac{-2}{9} \times \frac{-1}{9}$

Solution:

[a] $\frac{2}{5} \times \frac{4}{3} = \frac{2 \times 4}{5 \times 3} = \frac{8}{15}$

[b] $\frac{3}{7} \times \frac{-4}{5} = \frac{3 \times -4}{7 \times 5} = \frac{-12}{35}$

[c] $\frac{-2}{9} \times \frac{-1}{9} = \frac{-2 \times -1}{9 \times 9} = \frac{2}{9^2} = \frac{2}{81}$

Exercise (1- 6)

1 Find the value of each of the following:

[a] $\frac{3}{5} \times \frac{2}{7}$

[d] $-4\frac{2}{7} \times (-5\frac{1}{6})$

[b] $-\frac{3}{8} \times (-\frac{5}{3})$

[e] $-\frac{2}{3} \times \frac{5}{8}$

[c] $\frac{4}{5} \times (-\frac{3}{7})$

[f] $3\frac{1}{8} \times (-4\frac{1}{5})$

2 Find the value of each of the following:

[a] $1\frac{1}{2} \times \frac{4}{5}$

[c] $\frac{5}{6} \times (-1\frac{1}{15})$

[b] $-\frac{3}{4} \times 1\frac{1}{9}$

[d] $2\frac{3}{7} \times \frac{7}{17}$

3 Find the value of each of the following:

[a] $|\frac{-3}{7}| \times (-\frac{4}{3})$

[c] $2\frac{3}{4} \times (-3\frac{1}{5})$

[b] $|-1\frac{1}{2}| \times |\frac{-5}{3}|$







[d] $-4\frac{2}{7} \times (-8\frac{1}{6})$

Properties of multiplication operation in the set of rational numbers

1 Multiply: $\frac{2}{3} \times \frac{3}{4} = \dots$

Is the product a rational number?

2 Complete the table:

 × 			 × 
.....	$\frac{1}{2}$	$-\frac{3}{5}$
.....	$-\frac{4}{7}$	$-\frac{1}{3}$

Are the products equal if we change the position of the two numbers?

3 Complete:

$$[a] \quad \frac{-\frac{2}{5} \times (-\frac{3}{4})}{\frac{\dots}{20} \times \frac{1}{3}} \times \frac{1}{3} = \frac{-\frac{2}{5} \times (-\frac{3}{4} \times \frac{1}{3})}{-\frac{2}{5} \times \frac{\dots}{12}} = \frac{-\frac{2}{5} \times (-\frac{3}{4}) \times \frac{1}{3}}{\frac{-2 \times \dots \times \dots}{5 \times 4 \times 3}} = \frac{\dots}{60}$$

Does the multiplication of rational numbers have the grouping property?

[b] $-\frac{3}{5} \times 1 = \dots$, $1 \times (-\frac{7}{8}) = \dots$

Does the value of the rational number change if you multiply it by one?

[c] $\frac{5}{9} \times \frac{9}{5} = \dots$, $-\frac{7}{3} \times (-\frac{3}{7}) = \dots$

What do you notice?

[d] $-\frac{1}{2} \times [\frac{3}{7} + (-\frac{2}{7})] = -\frac{1}{2} \times \frac{\dots}{7} = \frac{\dots}{14}$

$$-\frac{1}{2} \times \frac{3}{7} + ((-\frac{1}{2}) \times (-\frac{2}{7})) = -\frac{\dots}{14} + \frac{\dots}{14} = \frac{\dots}{14}$$

What do you notice?

4 Write an example for each of the following properties of multiplication operation in the set of rational numbers

For any three rational numbers $\frac{a}{b}$, $\frac{c}{d}$ and $\frac{e}{f}$ then:

The property	Description in symbols	Example
1 - Closure	$\frac{a}{b} \times \frac{c}{d} = \frac{ac}{bd} \in \mathbb{Q}$	If $-\frac{1}{4}, -\frac{2}{3} \in \mathbb{Q}$ then $-\frac{1}{4} \times (-\frac{2}{3}) = \dots \in \mathbb{Q}$
2 - Commutative	$\frac{a}{b} \times \frac{c}{d} = \frac{c}{d} \times \frac{a}{b}$	
3 - Associative	$(\frac{a}{b} \times \frac{c}{d}) \times \frac{e}{f} = \frac{a}{b} \times (\frac{c}{d} \times \frac{e}{f})$ $= \frac{a}{b} \times \frac{c}{d} \times \frac{e}{f}$	
4 - Multiplicative-identity	$\frac{a}{b} \times 1 = 1 \times \frac{a}{b} = \frac{a}{b}$	
5 - Multiplicative-inverse	For every rational number $\frac{a}{b} \neq 0$, there exists a multiplicative inverse $\frac{b}{a}$ where: $\frac{a}{b} \times \frac{b}{a} = 1$	
6 - Multiplication distributes over addition	$\frac{a}{b} \times (\frac{c}{d} + \frac{e}{f}) =$ $(\frac{a}{b} \times \frac{c}{d}) + (\frac{a}{b} \times \frac{e}{f})$	

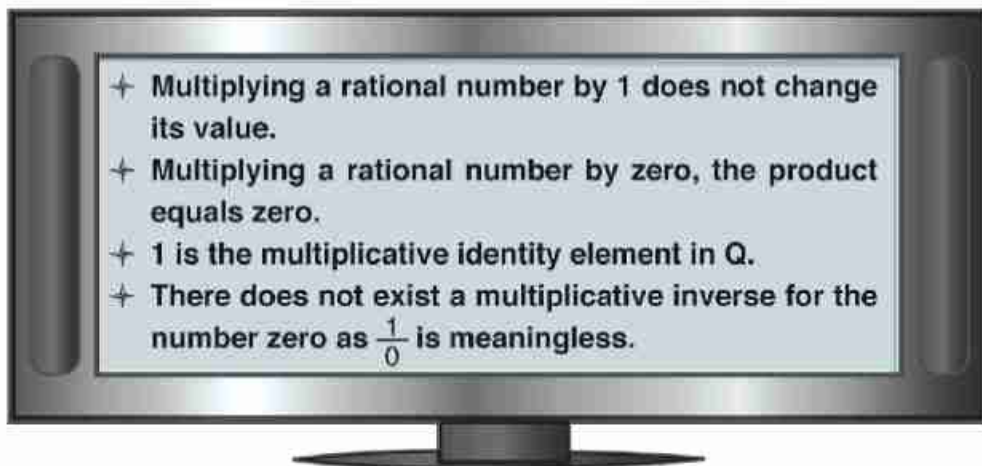

Exercise (1- 7)

1 State the property of the multiplication of rational numbers used in each of the following statements:

$$[a] -\frac{1}{2} \times \frac{2}{3} = \frac{2}{3} \times (-\frac{1}{2})$$

$$[d] \frac{5}{4} \times 1 = \frac{5}{4}$$

$$[b] -\frac{3}{7} \times (-\frac{7}{3}) = 1$$

$$[e] 0.8 \times 0 = 0$$

$$[c] -\frac{7}{20} \times (\frac{5}{2} \times 4) = (\frac{5}{2} \times 4) (-\frac{7}{20})$$

2 Complete:

$$[a] \frac{2}{3} \times (-\frac{4}{5}) = -\frac{4}{5} \times \dots$$

$$[d] -\frac{4}{11} \times \dots = 1$$

$$[b] \frac{2}{3} (2 + \frac{1}{2}) = \frac{2}{3} \times 2 + \dots$$

[e] The rational number which has no multiplicative inverse is ...

$$[c] \frac{2}{3} \times \frac{3}{2} = \dots$$

Mental Math

3 Find the value of n in each of the following:

$$[a] \frac{5}{7} \times n = \frac{5}{7}$$

$$[d] n \times \frac{17}{3} = 1$$

$$[b] -\frac{7}{3} \times n = 0$$

$$[e] -\frac{7}{3} \times (-\frac{3}{7}) = n$$

$$[c] n [\frac{1}{2} + (-\frac{3}{5})] = n \times \frac{1}{2} + 5 \times (-\frac{3}{5})$$

4 Use the properties of distribution of multiplication over addition of rational numbers to calculate each value:

$$[a] \frac{4}{9} \times 11 + \frac{4}{9} \times 16$$

$$[c] -\frac{3}{7} \times 8 + 5 \times (-\frac{3}{7}) + (-\frac{3}{7})$$

$$[b] \frac{5}{12} \times 3 + \frac{5}{12} \times 9$$

$$[d] \frac{18}{5} \times \frac{25}{9} + (-\frac{3}{7}) \times \frac{25}{9}$$

Division of two rational numbers

To divide the rational number $-\frac{2}{3}$ by $\frac{4}{5}$,

You multiply $-\frac{2}{3}$ by the multiplicative inverse of $\frac{4}{5}$ which is $\frac{5}{4}$

Complete:

$$-\frac{2}{3} \div \frac{4}{5} = -\frac{2}{3} \times \frac{5}{4} = -\frac{\dots}{\dots} = -\frac{\dots}{\dots}$$

If $\frac{a}{b}$ and $\frac{c}{d}$ are rational numbers

$\frac{c}{d} \neq 0$, then

$$\frac{a}{b} \div \frac{c}{d} = \frac{a}{b} \times \frac{d}{c}$$

Example (1)

Calculate the value of each of the following:

[a] $-\frac{5}{4} \div (-\frac{2}{3})$

[b] $-3\frac{3}{4} \div (-2\frac{1}{4})$

Solution

Since the dividend and divisor are both negative, the quotient is positive.

$$\begin{aligned} \text{[a]} \quad -\frac{5}{4} \div (-\frac{2}{3}) &= -\frac{5}{4} \times (-\frac{3}{2}) \\ &= \frac{5 \times 3}{4 \times 2} \\ &= \frac{15}{8} \end{aligned}$$

$$\begin{aligned} \text{[b]} \quad -3\frac{3}{4} \div (-2\frac{1}{4}) & \\ \frac{15}{4} \div \frac{9}{4} &= \frac{15}{4} \times \frac{4}{9} \\ &= \frac{15}{9} = \frac{5}{3} \end{aligned}$$

Example (2)

If $a = \frac{3}{4}$, $b = -\frac{5}{2}$, find in simplest form the numerical value of: $\frac{a-b}{a+b}$

Solution:

$$\begin{aligned} \frac{a-b}{a+b} &= \frac{\frac{3}{4} - (-\frac{5}{2})}{\frac{3}{4} + (-\frac{5}{2})} = \frac{\frac{3}{4} + (\frac{5 \times 2}{2 \times 2})}{\frac{3}{4} + (-\frac{5 \times 2}{2 \times 2})} = \frac{\frac{3}{4} + (\frac{10}{4})}{\frac{3}{4} + (-\frac{10}{4})} = \frac{\frac{13}{4}}{-\frac{7}{4}} \\ &= \frac{13}{4} \times (-\frac{4}{7}) = -\frac{13}{7} \end{aligned}$$

Exercise (1-8)

1 Calculate the value of each of the following, then put the result in its simplest form:

[a] $\frac{4}{5} \div \frac{3}{7}$

[d] $0 \div \frac{3}{5}$

[b] $\frac{8}{3} \div (-\frac{15}{7})$

[e] $-\frac{4}{5} \div \frac{7}{2}$

[c] $-14 \div (-\frac{4}{7})$

[f] $\frac{3}{8} \div (-7)$

2 Calculate the value of each of the following, then put the result in its simplest form:

[a] $-2\frac{1}{5} \div 5\frac{1}{2}$

[c] $-4\frac{2}{7} \div (1\frac{1}{14})$

[b] $-2\frac{3}{4} \div (-3\frac{1}{8})$

[d] $6\frac{1}{4} \div (-15)$

3 Calculate the value of each of the following, then put the result in its simplest form:

[a] $(-\frac{18}{5} \div \frac{9}{35}) \times (-\frac{3}{7})$

[c] $-1 \div 2\frac{1}{4}$

[b] $(-1\frac{2}{3} \times 4\frac{2}{3}) \div 6\frac{1}{9}$

[d] $[-\frac{12}{25} \times (-\frac{5}{7})] \div (-\frac{9}{14})$

4 If $x = \frac{3}{2}$, $y = -\frac{1}{4}$ and $z = -2$, find the simplest form of the numerical value of each of the following:

[a] $(x + z) \div (y - z)$

[b] $\frac{x+y}{z}$

Example (1)

Find the rational number half way between $\frac{9}{4}$ and $\frac{17}{6}$

Solution:

If the smaller number is $\frac{9}{4}$ and the greater number is $\frac{17}{6}$,

$$\begin{aligned}\frac{9}{4} + \frac{1}{2} \left(\frac{17}{6} - \frac{9}{4} \right) &= \frac{9}{4} + \frac{1}{2} \left[\frac{34}{12} + \left(-\frac{27}{12} \right) \right] \\ &= \frac{9}{4} + \frac{1}{2} \times \frac{7}{12} \\ &= \frac{9}{4} + \frac{7}{24} = \frac{54}{24} + \frac{7}{24} = \frac{61}{24} \quad \text{L.C.M of 4, 24 is 24}\end{aligned}$$

Then $\frac{61}{24}$ is a rational number between $\frac{9}{4}$ and $\frac{17}{6}$

Example (2)

Find the rational number that lies one third of the way between $-\frac{5}{6}$ and $-1\frac{1}{2}$ from the smaller.

Solution:

If the smaller number is $-1\frac{1}{2} = -\frac{9}{6}$ and the greater number is $-\frac{5}{6}$,

$$-\frac{9}{6} + \frac{1}{3} \left[-\frac{5}{6} - \left(-\frac{9}{6} \right) \right] = -\frac{9}{6} + \frac{1}{3} \times \frac{4}{6} = -\frac{9}{6} + \frac{4}{18} = -\frac{27}{18} + \frac{4}{18} = -\frac{23}{18}$$

Then $-\frac{23}{18}$ is a rational number that lies one third from $-1\frac{1}{2}$ to $-\frac{5}{6}$

Is there a rational number that lies one third of the way from $-\frac{5}{6}$ to $-1\frac{1}{2}$? due to the smallest

Exercise (1-9)

1 Choose the correct answer

[a] If $a \times \frac{b}{2} = \frac{a}{2}$, then $b = \dots$ [$\frac{a}{2}$, 0 , a , 1]

[b] If $\frac{x}{3} - 4 = 6$, then $\frac{x}{3} + \frac{2}{3} = \dots$ [1 , x , $\frac{32}{3}$, 10]

[c] If $4x - y = 11$, $y = 3x$, then $x = \dots$ [$\frac{1}{11}$, $\frac{7}{11}$, $\frac{11}{7}$, 11]

[d] If $\frac{x}{y} = 1$, then $2x - 2y = \dots$ [3 , 2 , 1 , 0]

2 Find the rational number in half-way between each of the following

[a] $\frac{3}{8}$, $\frac{4}{9}$

[d] $-\frac{37}{160}$, $-\frac{9}{42}$

[b] $\frac{7}{11}$, $\frac{3}{4}$

[e] $-4\frac{3}{5}$, $-5\frac{5}{6}$

[c] $-\frac{11}{9}$, $-\frac{13}{35}$

[f] $-4\frac{3}{7}$, $8\frac{1}{3}$

3 [a] Find the rational number that lies one third of the way between $\frac{4}{7}$ and $1\frac{3}{4}$ from the smaller.

[b] Find the number one fourth of the way between $-\frac{1}{9}$ and $-\frac{7}{8}$ from the smallest.

[c] Find the number one fifth of the way between $-\frac{2}{3}$ and $-\frac{3}{5}$ from the smaller.

[d] Find a rational number between $\frac{1}{3}$ and $\frac{3}{4}$

[e] Find a rational number between $-\frac{1}{5}$ and $-\frac{1}{9}$

Miscellaneous Exercises

1 Mark for the correct statement and for the incorrect one:

- [a] Every integer is a rational number.
- [b] Every rational number has a multiplicative inverse
- [c] The multiplicative inverse of a rational number is an integer.
- [d] Zero is a rational number.
- [e] The rational numbers $\frac{12}{16}$, $\frac{15}{20}$ and $\frac{3}{4}$ are represented with the same point on the number line
- [f] $2\frac{1}{5}$ is the multiplicative inverse for the rational number $5\frac{1}{4}$
- [g] $\frac{3}{x-3}$ is the additive inverse for the rational number $\frac{3}{3-x}$, where $x \neq 3$
- [h] $(\frac{2}{7} + \frac{3}{5})$ is the multiplicative inverse for the rational number $\frac{35}{31}$

2 Select the correct value:

- [a] If $x + \frac{2}{x} = 5 + \frac{2}{5}$, then $x = \dots$ [$\frac{1}{5}$, $\frac{4}{5}$, $\frac{5}{2}$, 5]
- [b] If $5a = 45$, $ab = 1$, then $b = \dots$ [$\frac{1}{45}$, $\frac{1}{9}$, $\frac{1}{5}$, 9]
- [c] If $\frac{x}{y} = \frac{2}{3}$, then $\frac{3x}{2y} = \dots$ [$\frac{1}{3}$, 1, $\frac{3}{2}$, $\frac{9}{4}$]
- [d] If $3x = 42$, then $\frac{5}{7}x = \dots$ [70, 45, 30, 10]

3 Complete in the same pattern:

[a] $6, 5\frac{1}{4}, 4\frac{1}{2}, \dots, \dots, \dots, \dots, \frac{3}{4}$

[b] $8, -4, 2, \dots, \dots, \dots, \frac{1}{8}$

4 If $x = -\frac{1}{3}$, $y = \frac{3}{4}$, $z = -3$, find the numerical value of each of the following.

- [a] xy [c] $\frac{xy}{z}$
- [b] $xy + yz$ [d] $\frac{x}{y} - \frac{y}{z}$

Activity (1):

Use the spreadsheet "Excel" to find the product of two integers

Click the start button on the task bar.

from the list of programs ... choose Microsoft Excel

by copying and completing the table

(Hint: Drag the "fill handle")

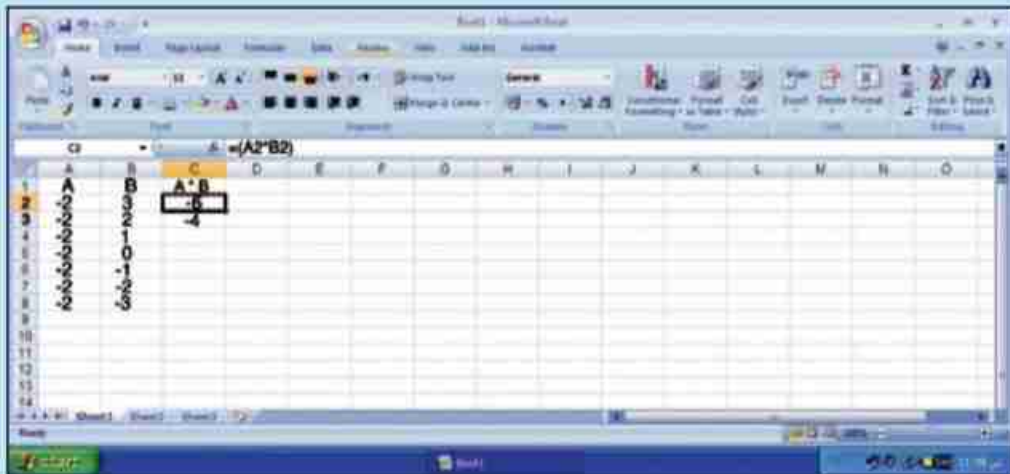

1 [a] Extend your spreadsheet up to row 15 using other values of a and b.

[b] Save what you have done in your folder

The flow chart below helping you to find the product of two integers.

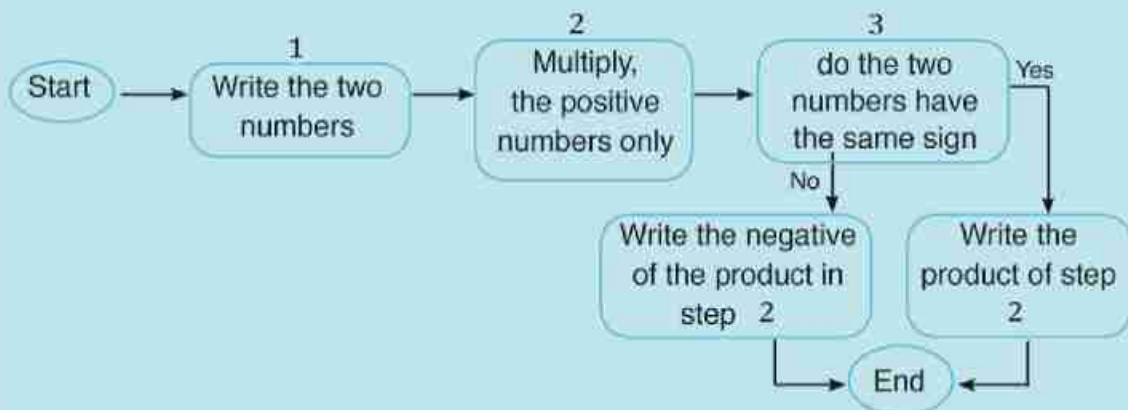

Activity (2):

Use the spread sheet "Excel" to find the quotient of two integers by copying and completing the table

(Hint: Drag the "fill handle")

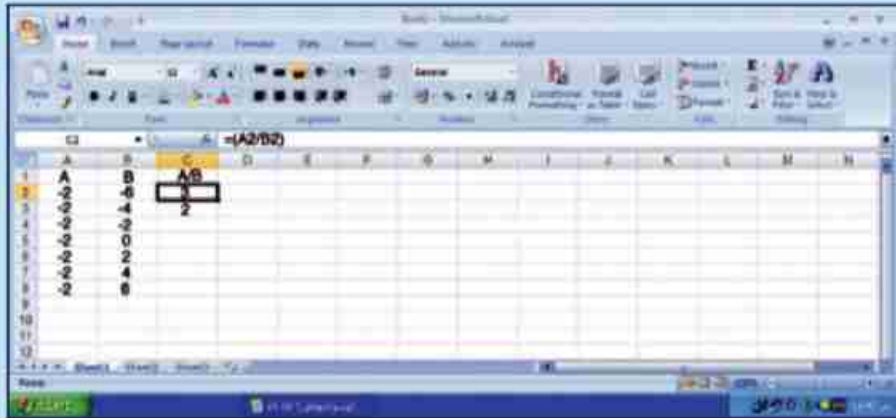

- 1 [a] Extend your spreadsheet up to row 15 using other values of a and b.
- [b] Save what you have done in your folder

The flow chart below suggests a means of computing the quotient of two integers.

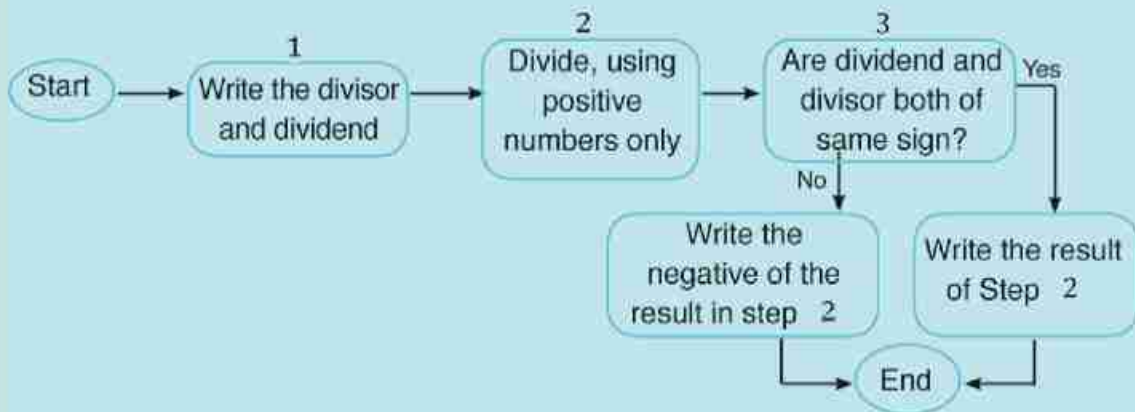

Unit test

1 Complete:

- [a] The multiplicative inverse of the rational number $-\frac{2}{3}$ is
- [b] To find the quotient of dividing $-\frac{7}{12}$ by $-\frac{3}{2}$, we have to multiply by
- [c] $0 \div (-14) = \dots\dots\dots$
- [d] $-\frac{4}{3} \times (-\frac{3}{4}) = \dots\dots\dots$
- [e] The rational number half way between $\frac{3}{5}$, $\frac{4}{5}$ is
- [f] $\frac{2}{3} \times (2 + \frac{1}{2}) = \frac{2}{3} \times 2 + \frac{2}{3} \times \dots\dots\dots$

2 Write the rational number n which makes each of the statements true:

- [a] $-\frac{3}{5} \times -\frac{5}{3} = n$
- [b] $(-3\frac{2}{3}) \times n = -3\frac{2}{3}$
- [c] The multiplicative inverse of $1\frac{2}{3}$ is n
- [d] $n \times [\frac{3}{4} + (-\frac{2}{3})] = \frac{1}{2} \times \frac{3}{4} + \frac{1}{2} \times (-\frac{2}{3})$

3 Evaluate:

- [a] $\frac{3}{4} \times (\frac{1}{2} - \frac{1}{3})$
- [b] $\frac{3}{5} \div (-\frac{9}{15})$
- [c] $-3\frac{1}{2} \div (-2\frac{1}{4})$
- [d] $\frac{7}{12} \times \frac{23}{45} + \frac{17}{12} \times \frac{23}{45} - 2 \times \frac{23}{45}$
- [e] $(\frac{1}{2} + \frac{3}{7}) \times [\frac{2}{6} + (-\frac{4}{5})]$

- 4 [a] If water flows through a pipe at the rate of $2\frac{1}{2}$ litres per minute, how many minutes will it take to fill three 20 litre containers?
- [b] How many pieces of wire $3\frac{3}{4}$ metres long can be cut from a wire 60 metres long?
Will any wire be left over? If so, how much?

5 Put the suitable sign ($<$, $=$, $>$):

[a] $-3\frac{1}{2}$ -4

[d] $|- \frac{13}{2}|$ $6\frac{1}{2}$

[b] $3\frac{1}{2}$ 4

[e] $\frac{392}{9}$ $44\frac{5}{8}$

[c] $-\frac{7}{3}$ 0

[f] $-\frac{214}{14}$ $-15\frac{2}{3}$

8 [a] If $x = \frac{3}{2}$, $y = -\frac{1}{4}$ and $z = -2$, Find in simplest form the numerical value of each of the following

(1) $x - z \div y$ (2) $\frac{x}{y} - \frac{z}{y}$ (3) $\frac{1}{xyz}$

[b] Find the product of:

$$\frac{1}{2} \times \frac{2}{3} \times \frac{3}{4} \times \frac{4}{5} \times \dots \times \frac{99}{100}$$

What is the product when the last rational number is $\frac{n-1}{n}$?

Muhammed Ibn Moussa Al Khowarezmy

(771 - 849)

Muslim, and Iraqi scientist

Arab are the first to use the word Algebra, the first of them is Al khowarezmy (the father of Algebra), thanks to Al khowarezmy, the world knew the use of the Arab digits which changed our concept of numbers, he also introduced the concept of zero.

**Contents**

- Lesson 1 : Algebraic terms and Algebraic expressions.
- Lesson 2 : like terms.
- Lesson 3 : Multiplying and dividing Algebraic terms.
- Lesson 4 : Adding and subtracting Algebraic expressions.
- Lesson 5 : Multiplying a monomial by an Algebraic expression.
- Lesson 6 : Multiplying a binomial by an Algebraic expression.
- Lesson 7 : Dividing an Algebraic expression by a monomial.
- Lesson 8 : Factorization by taking out the H.C.F.
- Miscellaneous Exercises
- Activities unit
- Unit test.

Lesson 1

Algebraic terms and Algebraic expressions

Mathematics is the language of symbols. We use the different symbols to express things or numbers, and we use these symbols by methods similar to that we use with numbers, for example:

- The length of this rectangle is 5 cm.
- The capacity of the bottle is "ℓ" litres.
- If the letter x stands for the length of the side of a square then $x \times x = x^2$ stands for its area.
- If the letter "a" stands for 1 apple, then $a + a + a = 3 \times a = 3a$ stands for 3 apples and is called an **algebraic term (monomial)**.
- If the letter P stands for 1 pound, then $-2P$ stands for losing 2 pounds:
 $(-P) + (-P) = -2 \times P = -2P$, and is called an algebraic term (monomial).

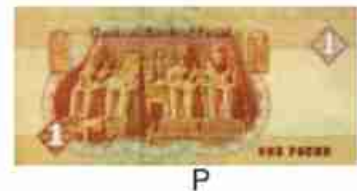
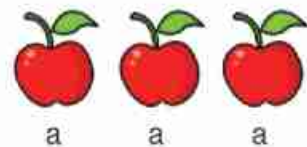
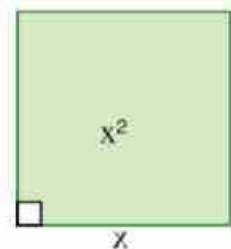

The algebraic term is formed from the product of two or more factors.

The algebraic term $a = 1 \times a$ consists of 2 factors: 1 (numerical), and a (algebraic).

The algebraic term $7x^2 = 7 \times x \times x$ consists of 3 factors:

7 (numerical), x (algebraic), and x (algebraic).

The algebraic term $3a$ is of first degree because the index of a is 1

The algebraic term $7x^2$ is of second degree because the index of x is 2

If we add the two terms $3a$ and $7x^2$, then $3a + 7x^2$ is called an **algebraic expression**

If we subtract $2P$ from $3a + 7x^2$, then $3a + 7x^2 - 2P$ is an called algebraic expression.

The algebraic expression $4x^3 - xy + 5$ is of the third degree because The index of x is the highest degree of the terms forming it.

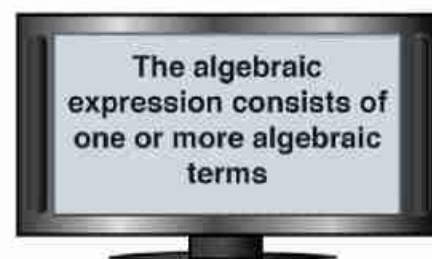

Exercise (2-1)

1 Complete:

Algebraic term	Coefficient	Degree
-7	-7	0
$2ab^2$	2	$1 + 2 = 3$
3
$7ab^3c$
$-8x^2b$
xy^2

2 Complete:

Algebraic expression	Number of terms	Name	Degree
$-3a^5b$	1	Monomial	6
$3x^2 + y$	2	binomial	2
$5x^3 - 7x + 4$		trinomial	
$2a^2b + 3ab^2 - a^2b^2$			
$x^2y^2 - 3xy^4$			
$a^2b - 3ab^3 + 2a^3b^2 + b^4$			

3 [a] Arrange the terms of the algebraic expression $7ab + 5a^5b^3 - 3a^2b^5$ according to the descending order of the indices of a.

[b] Arrange the terms of the algebraic expression $5x + x^2 - 7 + x^3$ according to the ascending order of the indices of x.

4 In this figure:

Write the algebraic expression which represents the area of the shaded region then state its degree.

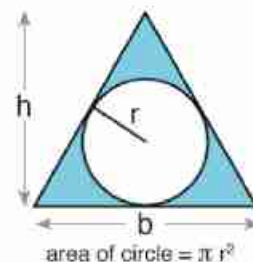

Lesson 2

Like terms

Algebraic terms are similar if the symbols forming its factors are similar and the indices of these symbols are similar.

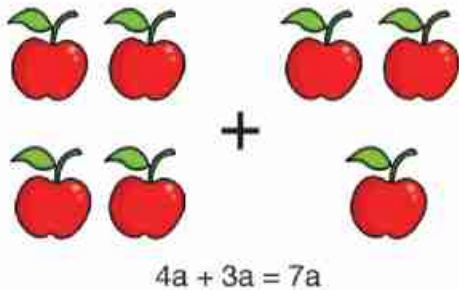

The terms $3a$ and $4a$ are like terms.

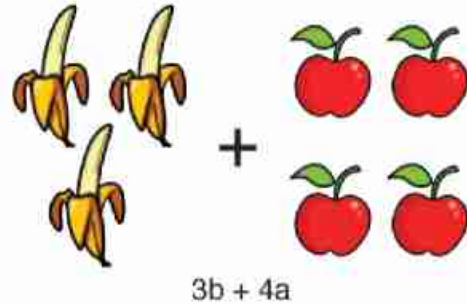

The terms $3b$ and $4a$ are unlike terms.

In adding and subtracting like terms, we add and subtract the coefficients of the terms, but the algebraic factors remain as they are.

Example (1)

Simplify: $9a - 4b - 2c - 5a + 7b + 3c$

Solution:

$$\begin{aligned} \text{The expression} &= (9a - 5a) + (-4b + 7b) + (-2c + 3c) \\ &= (9 - 5)a + (-4 + 7)b + (-2 + 3)c \\ &= 4a + 3b + c \end{aligned}$$

the expression contains groups of like terms so we use commutative, and distributive properties because unlike terms can not be added

Example (2)

In this figure:

Write the expression which represents areas of the rectangles.

Solution:

$$\begin{aligned} \text{The sum of areas} &= 3x^2 + 2x + 9x + 6 \\ &= 3x^2 + (2 + 9)x + 6 \\ &= 3x^2 + 11x + 6 \end{aligned}$$

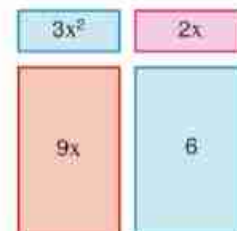

Exercise (2-2)

1 Complete:

Algebraic terms	Like terms	Unlike terms
$-2x, 2xy, x, -y$	$-2x, x$	
$-ab^2, 2a^2b, 3b^2a, -ab$		$2a^2b, -ab$
$x^2y^2, x^2, y^2, -3x^2y^2$		
$3a^4, -4a^3, a^2, -3a^2$		

2 Simplify:

[a] $3x - 5y - x + 2y$

[c] $2x - 4y - 9x - 3y$

[b] $7a + 6b - 11a + 9b$

[d] $19m - 4n + 11m - 17n + 9n$

3 Write down the algebraic expressions which represent the sum of the areas of the following rectangles:

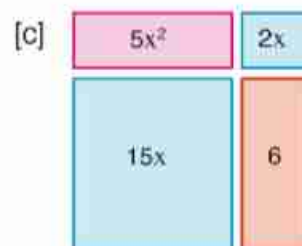
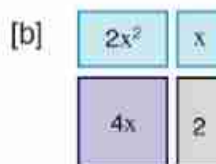
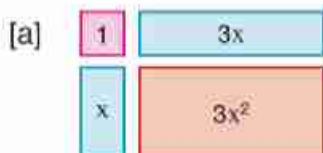

4 Simplify:

[a] $5x - 3x^2 + 4 - 7x^2 - 6x - 1$

[b] $6x^2y - 3xy^2 + 2xy^2 - 5x^2y + 2x^2y^2$

[c] $a^2 + 4a - 5 + 3a^2 - 6a + 1$

[d] $5x^2 - 2x + 8 - 7x - 3 + x^2$

Lesson 3

Multiplying and dividing algebraic terms

When multiplying the term $5a$ by the term $3b$, we write:

$$\begin{aligned} 5a \times 3b &= 5 \times a \times 3 \times b \\ &= (5 \times 3) \times (a \times b) \\ &= 15ab \end{aligned}$$

i.e we multiply the coefficients and then the symbols.

	b	b	b
a	ab		
a			
a			
a			
a			

When multiplying $5x^2$ by $3x^3$, we write:

$$\begin{aligned} 5x^2 \times 3x^3 &= (5 \times 3) \times (x^2 \times x^3) \quad \text{What happens when multiplying the like bases?} \\ &= 15x^{\dots} \end{aligned}$$

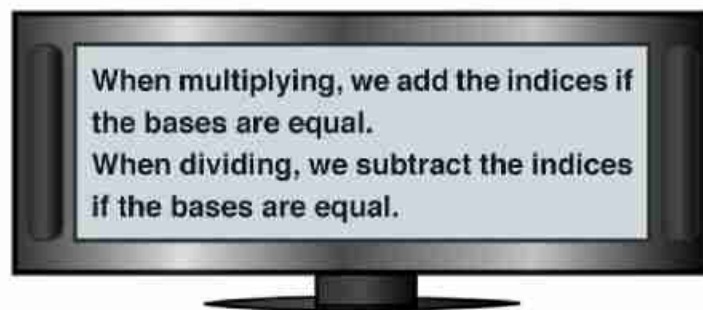

Complete:

$$\begin{aligned} \text{[a]} \quad x^2 \times x^3 &= (x \times x) \times (x \times x \times x) \\ &= x^{\dots} \times x^{\dots} = x^{\dots} \end{aligned}$$

$$\begin{aligned} \text{[b]} \quad -2x^6 \times (-5x^2) &= (-2 \times -5) \times x^6 \times x^2 \\ &= 10x^{\dots} \end{aligned}$$

$$\begin{aligned} \text{[c]} \quad \frac{x^5}{x^3} &= \frac{x \times x \times x \times x \times x}{x \times x \times x} \\ &= x^{\dots} \div x^{\dots} = x^{\dots} \end{aligned}$$

$$\text{[d]} \quad \frac{-2 \times x^6}{-5 \times x^2} = \frac{2}{5} x^{\dots}$$

Example (1)

Multiply each of the following

$$[a] \frac{1}{2} y^4 \times 2y^2 \qquad [c] -3b^6 \times \frac{1}{6} b$$

$$[b] \frac{21}{4} x^5 \times \frac{2}{7} x^3$$

Solution:

$$[a] \frac{1}{2} y^4 \times 2y^2 = y^{4+2} = y^6$$

$$[b] \frac{21}{4} x^5 \times \frac{2}{7} x^3 = \frac{3}{2} x^{5+3} = \frac{3}{2} x^8$$

$$[c] -3b^6 \times \frac{1}{6} b = \frac{-3}{6} b^{6+1} = \frac{-1}{2} b^7$$

Example (2)

The length of a rectangle is $4x$ cm and its width is $3x$ cm, calculate its area.

Solution:

$$\begin{aligned} \text{area of the rectangle} &= \text{length} \times \text{width} \\ &= 4x \times 3x = 12x^2 \text{ cm}^2 \end{aligned}$$

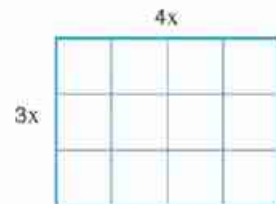

Example (3)

Divide each of the following

$$[a] \frac{4 a b^3}{8 a b} \qquad [b] \frac{3 m^2 n^4}{27 m n^2}$$

Solution:

$$[a] \frac{4 a b^3}{8 a b} = \frac{1}{2} x a^{1-1} \times b^{3-1} = \frac{1}{2} a^0 b^2 = \frac{1}{2} b^2$$

$$[b] \frac{3 m^2 n^4}{27 m n^2} = \frac{1}{9} m^{2-1} \times n^{4-2} = \frac{1}{9} m n^2 = \frac{1}{9} mn^2$$

Example (4)

Three tennis balls fit into a box. Calculate the ratio between the volume of the three balls and the volume of the box?

Solution:

Let "r" be the radius of the ball, The dimensions of the box: 6r, 2r, 2r

Ratio of the space occupied by the balls to the volume.

of the box is $\frac{\text{Volume of 3 balls}}{\text{Volume of the box}}$

$$= \frac{3 \times \frac{4}{3} \pi r^3}{6r \times 2r \times 2r} = \frac{4 \pi r^3}{24 r^3} = \frac{\pi}{6}$$

= 0.52 The three balls occupy over half the space of the box.

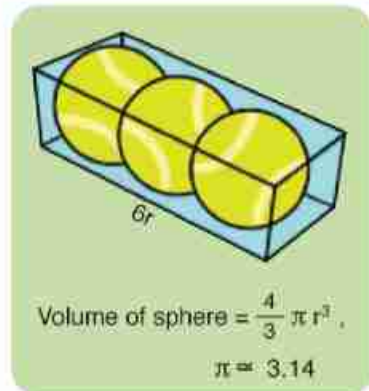

Exercise (2-3)

1 Multiply or divide:

[a] $5x^3y^4 \times 2xy^2$

[b] $5ab^2 \times (-2a^2b)$

[c] $-8y^5 \times (-7y^4)$

[d] $9x^5y^4 \div 6x^3y$

[e] $8m^4n^3 \div (-4mn^2)$

[f] $-32a^3b^6 \div (-4a^3b^2)$

2 Multiply:

[a] $\frac{2}{3}t^4 \times \frac{3}{2}t^4$

[b] $\frac{2}{7}a^2 \times 21a^5$

[c] $\frac{15a^3b}{2} \times \frac{8ab^2}{10}$

[d] $3x^3 \times \frac{1}{6}x^2$

[e] $\frac{4h^3k^3}{7} \times \frac{21hk^5}{2}$

[f] $4m^3 \times \frac{1}{4}m^2 \times (-7m)$

3 Complete:

[a] $36a^5b^8 = 12a^3b^2 \times \dots$

[b] $9a^5 = 3a \times \dots$

[c] $-4c^3d^3 = 2cd^2 \times \dots$

[d] $98a^7b^4 = \dots \times 14a^7b$

[e] $36a^8b^5 = 6ab^2 \times 3a^4b \times \dots$

[f] $42x^4y^5 = 3x^2y \times 2xy \times \dots$

5 Calculate the perimeter and the area of each shaded region:

[a]

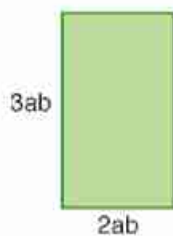

[b]

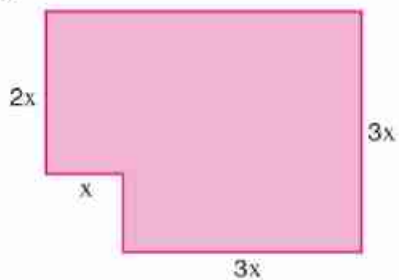

[c]

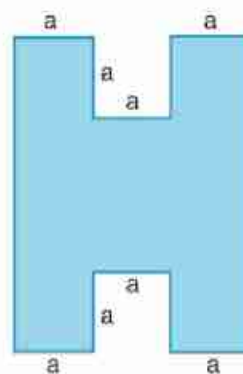

6 Calculate the total surface area and volume of each solid:

[a]



[b]

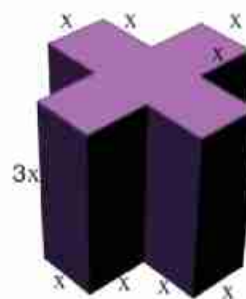

Lesson 4

Adding and subtracting algebraic expressions

Adding and subtracting algebraic expressions does not differ from adding and subtracting algebraic terms, That is by adding like terms in the expressions each one alone, or subtracting like terms in the expressions each one alone.

Example (1)

Add $2x - 5z + y$ and $7x + 4y - 2z$

Solution

Using the horizontal method

$$\begin{aligned} \text{The sum} &= 2x - 5z + y + 7x + 4y - 2z \\ &= (2x + 7x) + (-5z - 2z) + (y + 4y) \\ &= 9x - 7z + 5y \end{aligned}$$

Using the vertical method

$$\begin{array}{r} 2x - 5z + y \\ \quad 7x - 2z + 4y \\ \hline \text{The sum} = 9x - 7z + 5y \end{array}$$

Example (2)

Subtract $-a^2 - 5ab + 4b^2$ from $3a^2 - 2ab - 2b^2$

Solution:

Using the horizontal method

$$\begin{aligned} \text{The remainder} &= 3a^2 - 2ab - 2b^2 - (-a^2 - 5ab + 4b^2) \\ &= 3a^2 - 2ab - 2b^2 + a^2 + 5ab - 4b^2 \\ &= (3a^2 + a^2) + (-2ab + 5ab) + (-2b^2 - 4b^2) \\ &= 4a^2 + 3ab - 6b^2 \end{aligned}$$

Using the vertical method

Change the signs of the second expression then add

$$\begin{array}{r} 3a^2 - 2ab - 2b^2 \\ \quad \pm a^2 \pm 5ab \mp 4b^2 \\ \hline \text{The remainder} = 4a^2 + 3ab - 6b^2 \end{array}$$

Exercise (2-4)

1 Find the sum of:

[a] $(3x - 2y + 5)$ and $(x + 2y - 2)$

[c] $(3x^2 - 4x - 2)$ and $(-x^2 - 4x + 7)$

[b] $(3n^2 + 5n - 6)$ and $(-n^2 - 3n + 3)$

[d] $(3a^3 - 2ab^2)$ and $(a^3 - 4ab^2 - b^3)$

2 Find the sum of each of the following expressions:

[a] $3x - 4y + 2$

[b] $3a - 7b - 5c + 2$

[c] $5x + 2y - z + 2$

$- 3x + 7y + 3$

$- a + 4b + c - 5$

$7x + y - 3z + 3$

$2a + 3c + 3$

$- 2x - 5y + 4z - 1$

3 Subtract:

[a] $(x - 2)$ from $(2x - 5)$

[b] $(2x + 6y - 7)$ from $(2x - 5y + 2)$

[c] $(a + 2b + 3)$ from $(a - 3b + 5)$

[d] $(-x^2 - 4x + 7)$ from $(3x^2 - 4x - 2)$

4 [a] What is the increase of $x^2 - 5x - 1$ than $3x^2 + 2x - 3$

[b] What is the decrease of $2x - 8y - z$ than the sum of $3x - 3y + z$, $2x - 4y - 8z$

5 In the figure below: Calculate the total surface areas of the two solids.

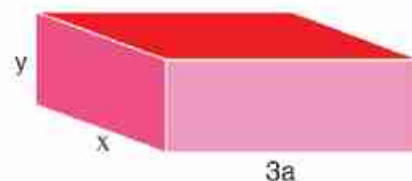
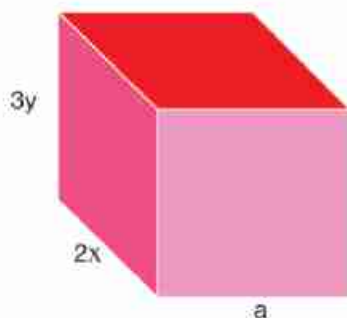

Lesson 5

Multiplying a monomial by an algebraic expression

1 The following figure on the right is a rectangle made up of three parts, A, B, and C. The dimensions of the rectangle are x and $(x + 2y)$ units.

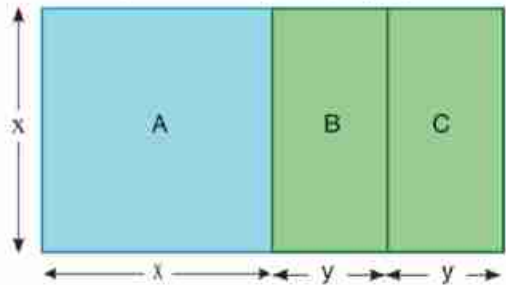

Therefore, the area of the rectangle
 $= x \times (x + 2y)$ square units.

[a] What is the area of the three parts A, B and C?

- Area of A =
- Area of B =
- Area of C =
- Area of B and C together =
- Area of A, B and C =

[b] Complete: $x(x + 2y) = \dots + \dots$



2 The figure below is a rectangle made up of two parts A and B, the dimensions of the rectangle are x and $3y$ units.

[a] Area of A and B together = , Area of A =

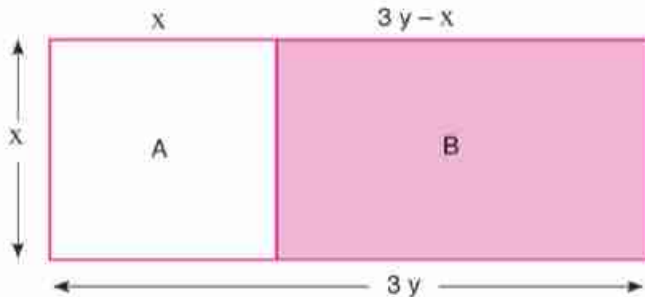

[b] Area of B = $x(3y - x)$



Example (1)

Multiply

[a] $3(x^2 - 4x)$

[b] $2xy(x^2y + 5y^3)$

Solution:

[a] $3(x^2 - 4x) = 3x^2 - 12x$

[b] $2xy(x^2y + 5y^3) = 2x^3y^2 + 10xy^4$

Example (2)

Simplify: $5(2x - 1) - 3(x^2 - 1) + x(5x - 1)$, then find the numerical value of the expression when $x = 1$

Solution:

$$\begin{aligned}
 5(2x - 1) - 3(x^2 - 1) + x(5x - 1) &= 10x - 5 - 3x^2 + 3 + 5x^2 - x \\
 &= 2x^2 + 9x - 2 \\
 \text{The numerical value} &= 2(1)^2 + (9 \times 1) - 2 = 2 + 9 - 2 = 9
 \end{aligned}$$

Exercise (2-5)

1 The opposite figure is a rectangle, its dimensions are x , $y + 2x$. It is divided into two smaller regions:

- [a] Calculate the sum of the areas of the two parts.
 [b] Calculate the product of the length and the width of the rectangular region.
 [c] Compare the answers of parts (a), and (b).
 What are the property of numbers does this diagram illustrate?

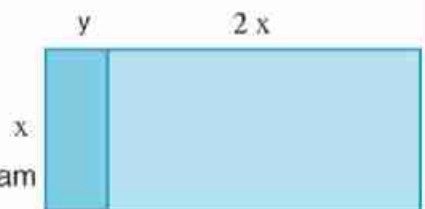

2 Find the area of each shaded region:

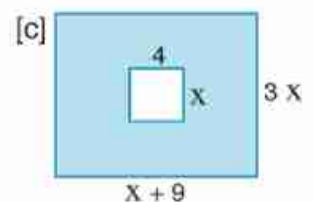
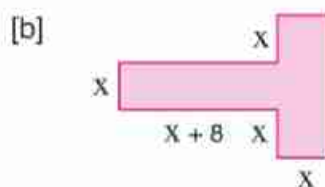
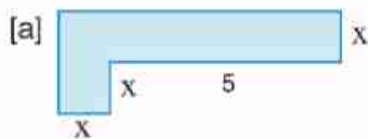

3 Simplify:

- | | | |
|--------------------|---------------------|-------------------|
| [a] $4(x - 3)$ | [d] $-3(y + 3)$ | [g] $a(a - 2)$ |
| [b] $3y(y + 5)$ | [e] $4(2x - 3)$ | [h] $-2c(7 - 3c)$ |
| [c] $2y^2 - y - 5$ | [f] $2k^2 - 3k - 7$ | |
| $\times 2y$ | $\times -3k$ | |
| | | |

4 Simplify:

- | | |
|---|--|
| [a] $\frac{1}{3}x^2(6x^2 - 9xy - 3y^2)$ | [c] $\ell m^2(\ell^2 - 3m\ell - 4m^2)$ |
| [b] $2x^2y(2x^2 - 3xy + y^2)$ | |

5 **Simplify:** $3(1 - 2x) - (x^2 - 5x + 3) + 2x(x + 3)$, then find the numerical value of the expression when $x = -2$

Lesson 6

Multiplying a binomial by an algebraic expression

- 1 This square is made up of four parts, A, B, C and D

The sides of the square are each $(x + y)$.

therefore the area of the square is

$(x + y)(x + y) = (x + y)^2$ square units.

Complete:

area of A + area D = +

area of B + area C = +

area of the square =

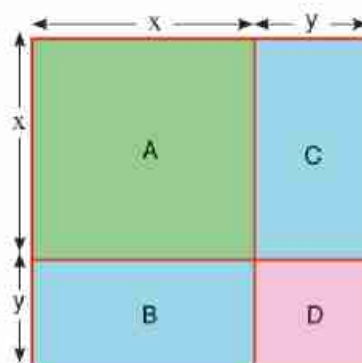

$$(x + y)^2 = \dots\dots\dots$$

Square of a binomial = square of the first monomial + 2 × product of the two monomials + square of the second monomial.

- 2 This figure is made up of four parts, A, B, C, and D.

Area of the square made up of A, B and C = $x \times x = x^2$ square units.

Therefore, the total area of the figure is $(x^2 + y^2)$ square units.

Complete:

area of A =

area of B + area of C = +

area of B + area of C + area D = + +

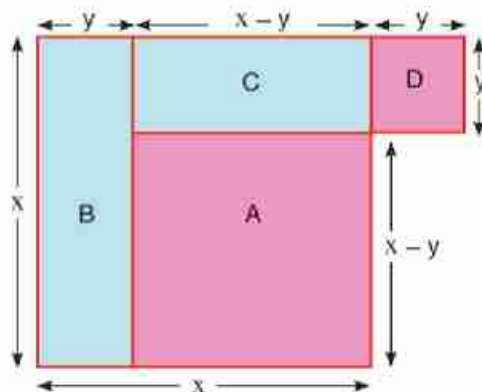

$$(x - y)^2 = \dots\dots\dots$$

$$x^2 + y^2 = (x - y)^2 + \dots\dots\dots$$

3 In the opposite figure:

- A small square B of area y^2 square units is removed from a bigger square A of area x^2 square units, therefore
The area of the remainder = $x^2 - y^2$ square units.

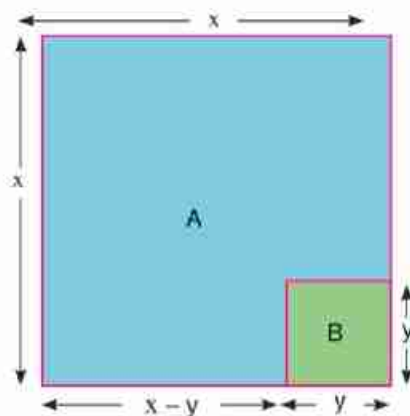

- Suppose the remaining area is cut into two portions then it is rearranged to form a rectangle, as shown:

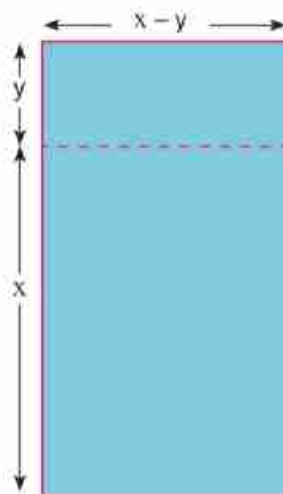

Complete:

[a] Area of the rectangle = $(x + y)(x - y)$

=

[b] $x^2 - y^2 = \dots\dots\dots$

4 The following figure shows the product of two binomials $(3x + 2)$, and $(2x + 5)$ can be thought of as the area of a rectangle as shown in the following diagrams:

Complete:

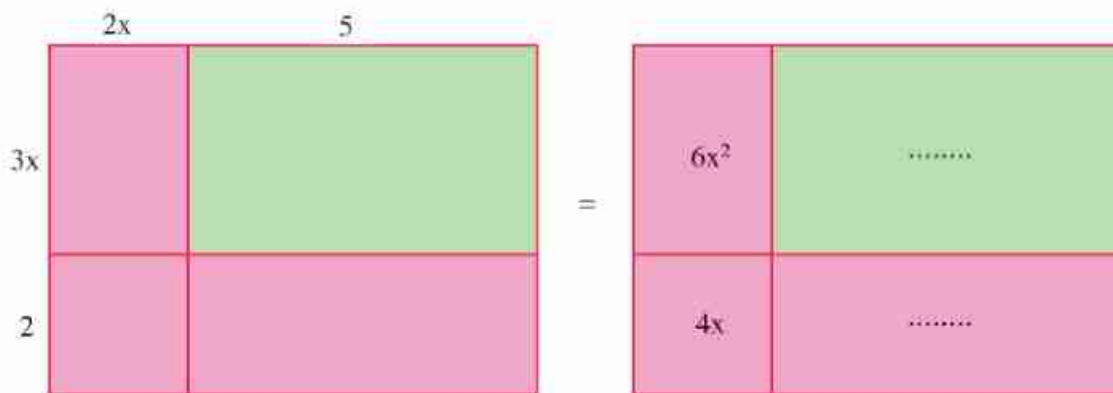

$(3x + 2)(2x + 5) = \dots\dots + \dots\dots + \dots\dots + \dots\dots$
 $= \dots\dots + \dots\dots + \dots\dots$

Horizontal method

$$\begin{aligned} (3x + 2)(2x + 5) &= 3x(2x + 5) + 2(2x + 5) \\ &= \dots + \dots + \dots + \dots \\ &= \dots + \dots + \dots \end{aligned}$$

Vertical method

$$\begin{array}{r} 3x + 2 \\ 2x + 5 \\ \hline 6x^2 + 4x \\ \quad \dots + \dots \\ \hline 6x^2 + \dots + \dots \end{array}$$

Inspection method

$$\begin{aligned} &\begin{array}{c} \text{---} \text{---} \text{---} \\ \downarrow \quad \downarrow \\ (3x + 2)(2x + 5) \\ \uparrow \quad \uparrow \\ = 6x^2 + (\dots + \dots) + 10 \\ = 6x^2 + \dots + \dots \end{array} \end{aligned}$$

5 Complete:

- [a] $(3x + 2)(x + 7) = 3x^2 + \dots + 14$
- [b] $(3x - 2)(x - 7) = \dots$
- [c] $(3x - 2)(x + 7) = \dots$
- [d] $(3x + 2)(x - 7) = \dots$
- [e] $(x + 5y)(x - 5y) = \dots$
- [f] $(x - 4)(x + 4) = \dots$
- [g] $(2x + y)^2 = \dots$
- [h] $(2x - y)^2 = \dots$

6 In this figure:

What is the area of the shaded part of the rectangle?

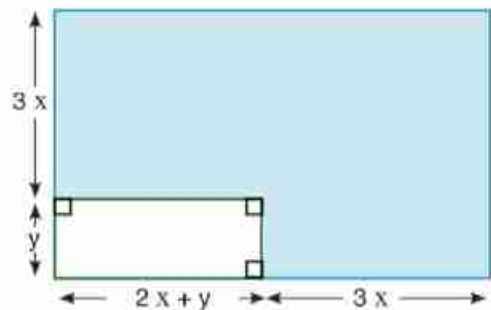

Solution:

	Length	Width	Area
Large rectangle	$5x + y$	$3x + y$	$(5x + y)(3x + y)$
Small rectangle	$2x + y$	y	$(2x + y)y$

Shaded area = $\dots - \dots = \dots$

7 Use the previous methods to find: $(x + y)(2x + y + 1)$

Example (1)

Multiple the following:

$$[a] (2x + 3y)^2$$

$$[c] (m - 7n)^2$$

$$[b] (5a - b)(5a + b)$$

Solution:

$$\begin{aligned} [a] (2x + 3y)^2 &= (2x)^2 + 2x \times 3y \times 2 + (3y)^2 \\ &= 4x^2 + 12xy + 9y^2 \end{aligned}$$

$$\begin{aligned} [b] (5a - b)(5a + b) &= (5a)^2 - (b)^2 \\ &= 25a^2 - b^2 \end{aligned}$$

$$\begin{aligned} [c] (m - 7n)^2 &= (m)^2 - m \times 7n \times 2 + (7n)^2 \\ &= m^2 - 14mn + 49n^2 \end{aligned}$$

Example (2)

Multiply, then find the numerical value at $x = 2$, $y = 1$

$$[a] (x + 9)(x + 2)$$

$$[c] (2x + y)(x + 2y)$$

$$[b] (y + 3)(y + 1)$$

Solution:

$$\begin{aligned} [a] (x + 9)(x + 2) &= x^2 + 11x + 18 \quad \text{at } x = 2 \\ &= (2)^2 + 11 \times 2 + 18 = 4 + 22 + 18 = 44 \end{aligned}$$

$$\begin{aligned} [b] (y + 3)(y + 1) &= y^2 + 4y + 3 \quad \text{at } y = 1 \\ &= (1)^2 + 4 \times 1 + 3 = 8 \end{aligned}$$

$$\begin{aligned} [c] (2x + y)(x + 2y) &= 2x^2 + 5xy + 2y^2 \quad \text{at } x = 2 \\ &= 2 \times (2)^2 + 5 \times 2 \times 1 + 2 \times (1)^2 \\ &= 8 + 10 + 2 = 20 \end{aligned}$$

Exercise (2–6)

1 Simplify Multiply the following:

[a] $(4x + 1)(2x + 3)$

[b] $(5m - 2)(6m + 1)$

[c] $(8x - 2)(3x - 7)$

[d] $(4m - 7)^2$

[e] $(3x + y)^2$

[f] $(4m - 7)(4m + 7)$

[g] $(6x - 2y)(6x + 2y)$

[h] $(-12m + 9)(-12m - 9)$

2 Simplify:

[a] $3(m - 5)(m + 2)$

[b] $3a(2a - 5b)(3a + b)$

[c] $3x(2x + 4y)^2$

[d] $4(xy - 2)^2$

[e] $(5x - 2y)^2 - (5x + 2y)^2$

[f] $(2x^2 + 3)(x^2 - 5) - (3x^2 + 2)^2$

3 Select the correct value:

[a] If $(2x + y)^2 = 4x^2 + kxy + y^2$, then $k = \dots\dots$ [2, 4, 8]

[b] If $(x - y)(2x + y) = 2x^2 + kxy - y^2$, then $k = \dots\dots$ [-1, 1, 3]

[c] If $(x - 3)(x + 3) = x^2 + k$, then $k = \dots\dots$ [9, 6, -9]

4 Write an expression for the perimeter and area of each shaded region:

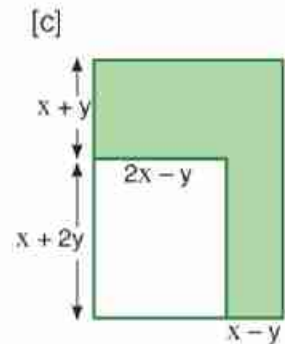
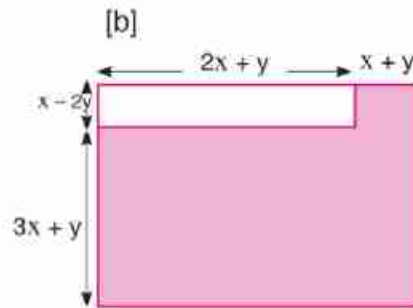
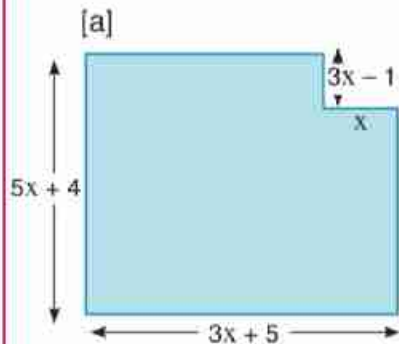

5 Multiply then calculate the numerical value of the product by substitution

When $x = 1$, $y = -2$:

[a] $(2y + 7)(3y + 4)$

[c] $(x + 4)(3x + 2)$

[b] $(3x + y)(x + 3y)$

[d] $(x + 4)^2(3y + 2)$

6 Simplify:

[a] $(2y + 1)(y^2 + y + 5)$

[c] $(7n + 2)(2n^2 - 5n + 1)$

[b] $(4 + 2a + 3a^2)(2 - a)$

[d] $4x^2 + x - 5$

$\times \frac{x + 6}{\dots\dots\dots}$

7 [a] If $(2 - y)^3 = 8 - 12y + 6y^2 - y^3$ obtain the value of $(2 - y)^4$

[b] Use **Mental Math** to find the value of:

1) $(41)^2$ in the form $(40 + 1)^2$

2) $(49)^2$ in the form $(50 - 1)^2$

3) 201×199 in the form $(200 + 1)(200 - 1)$

Lesson 7

Dividing an algebraic expression by a monomial

This figure is a rectangle made up of three parts.
Area of the rectangle = $(x^2 + 2xy)$

The length of the rectangle =
Area of the rectangle \div Width of the rectangle

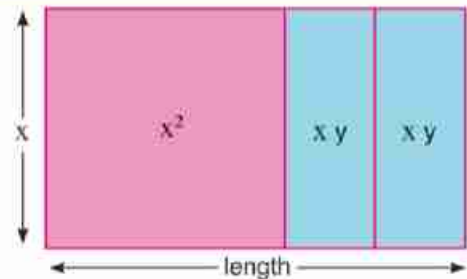

The length of the rectangle = $\frac{x^2 + 2xy}{x} = \frac{x^2}{x} + \frac{2xy}{x} = \dots + \dots$

1 Complete:

[a] The length of the rectangle whose area $x^2 + xy = \frac{x^2 + xy}{\dots} = \dots + \dots$

[b] The length of the rectangle whose area $2xy = \frac{2xy}{\dots} = \dots$

[c] The length of the rectangle whose area $xy = \frac{xy}{\dots} = \dots$

[d] The length of the square whose area $x^2 = \frac{x^2}{\dots} = \dots$

2 The following figure is a rectangle made up of three parts, its area is $(2ab + 6ac + 12ad)$

Length of the rectangle = area \div width

$$\begin{aligned} &= \frac{\dots + \dots + \dots}{2a} \\ &= \frac{\dots}{2a} + \frac{\dots}{2a} + \frac{\dots}{2a} \\ &= \dots + \dots + \dots \end{aligned}$$

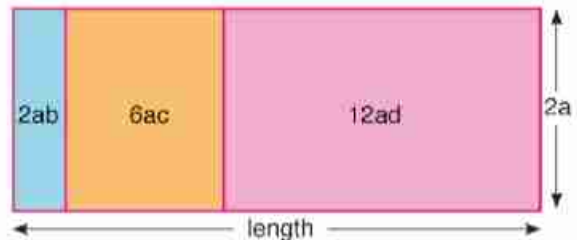

Example

Divide each of the following

[a] $\frac{26e^2 + 14e^4}{2e}$

[b] $\frac{9l^3m^4 - 18lm^4}{3lm^2}$

Solution:

[a] $\frac{26e^2 + 14e^4}{2e} = \frac{26e^2}{2e} + \frac{14e^4}{2e} = 13e + 7e^3$

[b] $\frac{9l^3m^4 - 18lm^4}{3lm^2} = 3l^2m^2 - 6m^2$

Exercise (2-7)

The symbols in the following monomials and algebraic expressions represent non - zero numbers.

1 Complete:

$$[a] \frac{18a^5 b^2}{6a^2} = \frac{18}{6} \times \frac{a^5}{a^2} \times \frac{b^2}{1} = \dots$$

$$[b] \frac{15n^3 - 9m^4 n^2}{-3n^2} = \frac{15n^3}{-3n^2} + \frac{-9m^4 n^2}{-3n^2} = \dots + \dots$$

$$[c] \frac{12x^3 - 8x}{4x} = \frac{12x^3}{4x} - \frac{8x}{4x} = \dots - \dots$$

$$[d] \frac{16x^4 y^2 - 12x^3 y^3 + 24x^2 y^4}{8x^2 y} = \frac{16x^4 y^2}{8x^2 y} - \frac{\dots}{8x^2 y} + \frac{\dots}{8x^2 y} = \dots - \dots + \dots$$

2 Find the quotient in each case:

$$[a] \frac{18a^2}{3a}$$

$$[d] \frac{18x^4 y^5 - 42x^5 y^4}{-6x^2 y^2}$$

$$[b] \frac{18m^4 + 32m^2}{-2m^2}$$

$$[e] \frac{24x^4 - 18x^3 - 42x^2}{6x^2}$$

$$[c] \frac{48x^3 - 80x^2}{8x^2}$$

$$[f] \frac{32x^5 - 48x^3 + 72x^7}{-8x^3}$$

Lesson 8

Dividing an algebraic expression by another one

In the opposite figure:

A model of peice of land rectngular shape its area $(x^2 + 5x + 6) \text{ m}^2$ and its width is $(x + 2) \text{ m}$, find its length to get the length of the rectangle you have to find the quotient of $x^2 + 5x + 6$ by $x + 2$

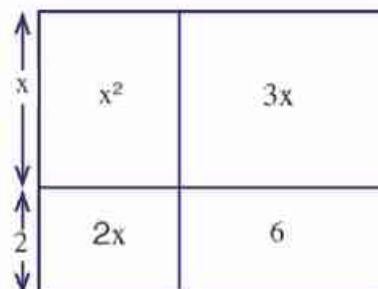

Solution:

[a] Rearrang the dividend $(x^2 + 5x + 6)$ and the divisor $(x + 2)$ according to the desendingly powers of x .

[b] Divide x^2 by x the result x

$$\begin{array}{r} x^2 + 5x + 6 \\ x + 2 \end{array}$$

[c] Multiply x by the divisor

$$\begin{array}{r} x^2 + 5x + 6 \\ -x^2 + 2x \\ \hline 3x + 6 \end{array}$$

[d] Subtract $x^2 + 2x$ from $x^2 + 5x + 6$ to get

$$\begin{array}{r} x^2 + 5x + 6 \\ -x^2 + 2x \\ \hline 3x + 6 \end{array}$$

[e] Repeat the steps 2, 3, 4 to be

$$\begin{array}{r} 3x + 6 \\ -3x + 6 \\ \hline 0 \quad 0 \end{array}$$

the final subtraction equals zero

\therefore The quotient = $x + 3$ the length of the rectangle

Example (1)

Find the quotient of $x^3 + 1$ by $x + 1$

Solution:

$$\begin{array}{r} x^3 + \quad +1 \\ -x^3 + x^2 \\ \hline -x^2 + 1 \\ +x^2 + x \\ \hline x + 1 \\ -x + 1 \\ \hline 0 \quad 0 \end{array}$$

\therefore The quotient = $x^2 - x + 1$

Example (1)

Find the value of k which makes the expression

$2x^3 - x^2 - 5x + k$ is divisible by $2x - 3$

Solution:

$$\begin{array}{r|l} 2x^3 - x^2 - 5x + k & 2x - 3 \\ \hline -2x^3 + 3x^2 & x^2 + x - 1 \\ \hline 2x^2 - 5x + k & \\ -2x^2 + 3x & \\ \hline -2x + k & \\ +2x - 3 & \end{array}$$

$$\therefore k - 3 = 0 \longrightarrow k = 3$$

Exercise (2-8)

1 Find the quotient of each of the following:

- [a] $2x^2 + 13x + 15$ by $x + 5$
- [b] $3x^3 - 4x + 1$ by $x - 1$
- [c] $3x^2 + x^3 - x - 3$ by $x^2 - 1$
- [d] $x^4 + 3x^2 + 2$ by $x^2 + 1$
- [e] $x^4 + 49 - 18x^2$ by $2x - 7 + x^2$
- [f] $x^3 - 27$ by $x - 3$

2 Find the value of k which makes the expression

[a] $x^3 - 3x^2 - 25x + k$ is divisible by
 $x^2 + 4x + 3$

- [b] If the area of rectangle is $(2x^2 + 7x - 15)$ and its length is $(x + 15)$. Find its width and its perimeter at $x = 3\text{cm}$

Lesson 9

Factorization by Identifying the highest common factor (H.C.F.)

Draw a rectangle whose dimensions are 7, 4 units on a squared paper, and a rectangle whose dimensions are 5, 4 of the same units.

Calculate the area of the two rectangles by two different methods.

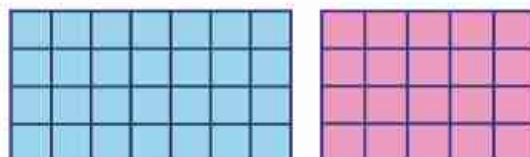

First method

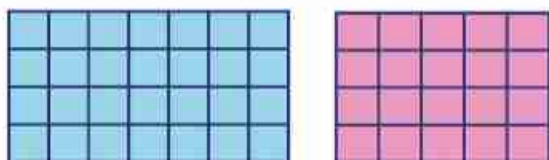

$$\begin{aligned} \text{Area of rectangles} &= (4 \times 7) + (4 \times 5) \\ &= \dots + \dots = \dots \end{aligned}$$

Second method

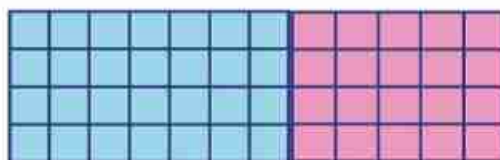

$$\begin{aligned} \text{Area of rectangles} &= 4 \times (7 + 5) \\ &= 4 \times \dots = \dots \end{aligned}$$

Note that

$4 \times (7 + 5) = (4 \times 7) + (4 \times 5)$ means that we used distributing multiplication on addition, while $(4 \times 7) + (4 \times 5) = 4 \times (7 + 5)$ means factorization by identifying the H.C.F. between the two terms (4×7) and (4×5) , which is 4. Each of 4, $(7 + 5)$ is called a factor of the expression $4(7 + 5)$

Generally: $a b + a c = a (b + c)$

Example (1)

Factorize by identifying the H.C.F. of the expression:

$$3x^2 y^3 - 9x^3 y^4 + 12x^3 y^2$$

Solution

The H.C.F. = $3x^2 y^2$

To find the other factor, we divide each term by the H.C.F.

$$\begin{aligned} 3x^2 y^3 - 9x^3 y^4 + 12x^3 y^2 \\ = 3x^2 y^2 (y - 3x y^2 + 4x) \end{aligned}$$

Example (2)

Factorize by identifying the H.C.F. of the expression:

$$3a(4a + 5b) - 2b(4a + 5b)$$

Solution

The H.C.F. = $(4a + 5b)$

$$\begin{aligned} 3a(4a + 5b) - 2b(4a + 5b) \\ = (4a + 5b)(3a - 2b) \end{aligned}$$

Exercise (2-9)

1 Factorize by identifying the H.C.F.:

[a] $3x^2 + 6x$

[d] $35a + 10a^2$

[b] $8y^2 - 4x^2$

[e] $49b^2 - 7b^3$

[c] $5y - 10$

[f] $3x^2 + 12x - 6$

2 Factorize by identifying the H.C.F.:

[a] $12a^2 b + 18a^3 b^2$

[b] $9m^4 n^2 - 6m^3 n^3 + 12m^2 n^4$

[c] $18a^2 bc - 6abc + 30abc^2 - 24ab^2 c^2$

[d] $-2x^5 + 4x^2 - 6x + 2x^3$

[e] $3x(a+b) + 7(a+b)$

[f] $(x+4)x^2 + (x+4)y^2$

[g] $3x^2(x-7) + 2x(x-7) + 5(x-7)$

[h] $4m^2(2x+y) - 3m(2x+y) - 7(2x+y)$

3 Find the result by identifying the H.C.F.:

[a] $7 \times 123 + 7 \times 35 - 7 \times 18$

[b] $6 \times 15^2 + 18 \times 15 - 8 \times 15$

Miscellaneous Exercises

1 Circle the correct answer:

[a] If $a = 0$, $b = 5$, and $c = 2$, then the numerical value of $a^2 b + ac$ equals.....
[0, 2, 6, 8]

[b] If the price of 4 shirts is L.E X, then the price of 40 shirts is
[$10x$, $\frac{x}{40}$, $\frac{5x}{2}$, $\frac{40}{4}$]

[c] If $\frac{a}{b} = 70$, then $\frac{a}{2b} = \dots\dots$
[35, 68, 72, 140]

[d] $7x^2 + 14y^2 = 7$ (.....)
[$x^2 + y^2$, $x^2 + 2y^2$, $7x^2 + y^2$, $x + 2y$]

[e] $(15x^4 + 5x^3) \div 5x^3 = \dots\dots$
[$3x^2 + x$, $5x^2 + 1$, $3x + 1$, $4x^4$]

[f] $\frac{3x}{7} - \frac{x}{7} = \dots\dots$
[$\frac{2}{7}$, $\frac{x}{7}$, $\frac{2x}{7}$, $2x$]

[g] The volume of the cuboid is

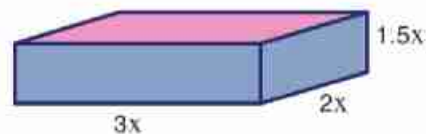

[$6.5x$, $2(5x)(1.5x)$, $9x^3$, $2(4.5x^3)$]

[h] If $x = 4$, $y = 6$, and $z = 24$, which of the following is true?

[$x = \frac{z}{y}$, $x = \frac{y}{z}$, $x = yz$, $x = y + z$]

2 Complete:

[a] The degree of the term $3x^2 y$ is and its coefficient is

[b] $6a^2 + 12 ab = 3a$ (..... +)

[c] $x(a + 1) - y(a + 1) = (a + 1)$ (.....)

[d] $(4a^2 + 2a) \div 2a = \dots\dots$

[e] $7 + 7^2 + 8 + 8^2 = \dots\dots \times 8 + \dots\dots \times 9$

[f] $(31)^2 = 901 + 2 \times \dots\dots \times \dots\dots$

[g] $(20 + 1)(20 - 1) = 400 - \dots\dots$

[h] The seventh term in the pattern: $\frac{1}{10000}$, $\frac{1}{1000}$, $\frac{1}{100}$,, is

3 Simplify to simplest form:

[a] $4a + 9b + 5a - 2b + 6b - 3a$

[b] $3x^2 + 5x^3 + x^2 + 2x^3$

[c] $2x^3 y^2 \times 4x^2 y^3$

[d] $2x(3x + y) + 3y(x + y)$

4 Use two methods to simplify:

[a] $\frac{x^3 + xb^2}{xb}$

[b] $\frac{19^2 - 2 \times 19 + 19}{19}$

5 Write the product:

[a] $(2x - 5y)(2x + 5y)$

[b] $(2x - 5y)(2x - 5y)$

[c] $(x + 1)(x^2 - x + 1)$

[d] $(x - 3y)^2$

[e] $(2x - y)^2$

[f] $(3a - 5b)(2a + 7b)$

6 Factorize by identifying the H. C. F.:

[a] $16x^3 + 8x^2$

[b] $15a^3 b^4 + 6a^5 b^3 - 3a^2 b^2$

[c] $15 \times 17 + 15 \times 13 - 15 \times 30$

[d] $5(48)^2 + 7 \times 48 + 53 \times 48$

7 [a] By what expression is $3x^2 - 5 + 2x$ increased from the sum of

$x + 5x^2 + 1$ and $2x^2 - 4 - 2x$

[b] Simplify: $2n(n + 5) + n(6 - n)$, then calculate the numerical value when $n = -1$

8 Find the area of the shaded region:

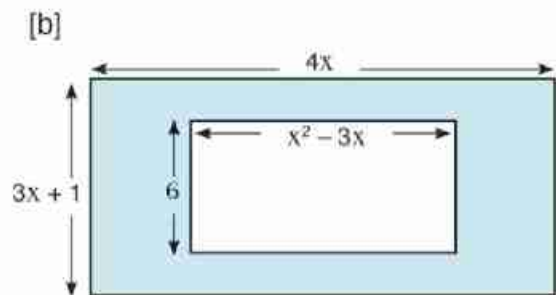
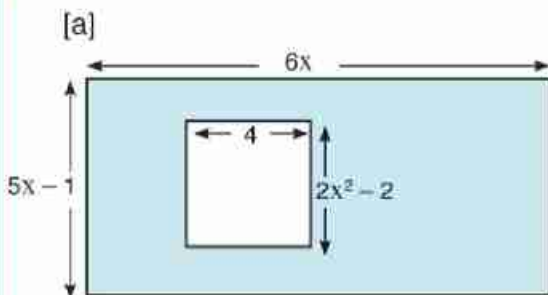

9 [a] If $a = 4x - 3$, $b = 2x + 1$, and $c = 3x - 2$. Find in terms of x the value of the expression: $ab - c^2$

[b] Multiply: $(x - 2y)(x + 2y)$ by $(x^2 + 4y^2)$

10 Complete:

[a] $5x^2 + 3$ is an algebraic expression of the degree.

[b] $(2x - 1)^2 = \dots - 4x + 1$

[c] $a^2 b + b^2 a = \dots (a + b)$

[d] $(x - 5)(\dots) = x^2 - 25$

11 Circle the correct value:

[a] The Algebraic term $2x^3$ has factors. [2, 3, 4, 5]

[b] $4x^2 y^2 - 2xy^2 + 4x^2 y = \dots (2xy - y + 2x)$ [4xy, 2xy, 2x, 2y]

[c] If $2b$ is the length of a cube then its volume equals [4b², 2b³, 4b³, 8b³]

[d] This figure is a rectangle with dimensions $2a$, $3b$ then its perimeter is [6 ab, 2a + 3b, 4a + 6b, (2a + 3b)²]

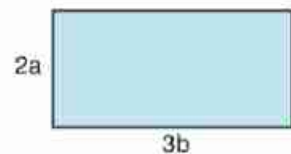

[e] The factorization of $6x^2 y - 4x$ by identifying the H.C.F. is

[3xy (x + y), 2xy (3y - 2), 2xy (3x - 2), 2x (3xy - 2)]

12 Find the quotient of each of the following:

[a] $x^2 + 3x + 2$ by $x + 1$

[b] $37x^2 - 4 - 9x^4$ by $3x^2 - 2 + 5x$

Activity (1):

Use the spreadsheet "Excel" to verify the law: $a^m \times a^n = a^{m+n}$ applies to indices

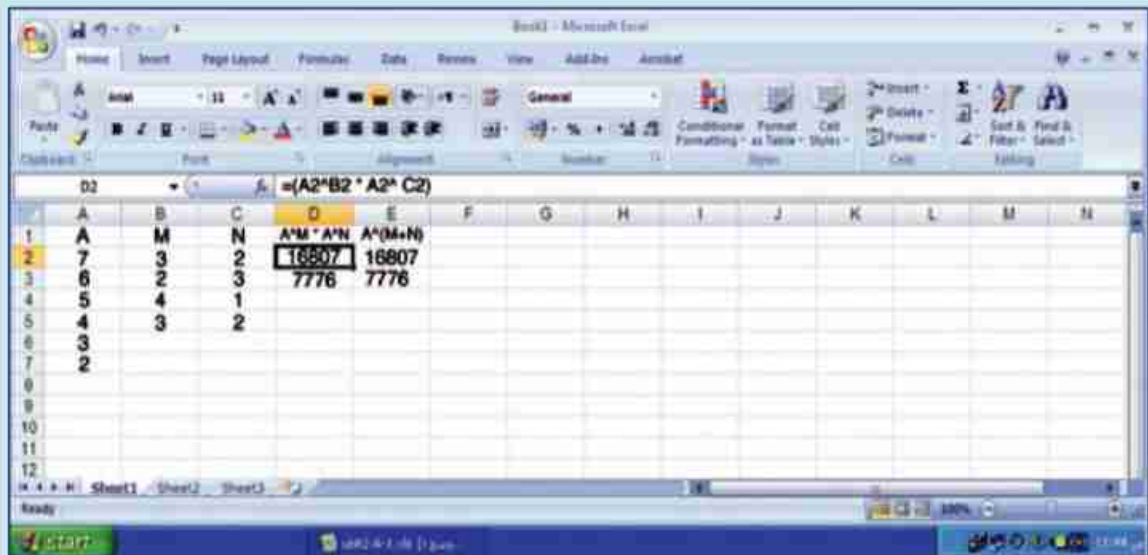

- Extend your spreadsheet up to row 15 using other positive values of a , m , and n
- Does the law produce consistent outcomes?
- Does the law apply to negative bases ($a < 0$)?
- Use the same method to verify the law $a^m \div a^n = a^{m-n}$, $m \geq n$, and $a > 0$
- Does the law apply to negative bases ($a < 0$)?
- Attach a printed copy of your completed spreadsheet to show your work.

Activity (2):

1 Copy the following table on a spreadsheet (Excel):

	A	B	C	D	E	F
1	A	B	$(A+B)^2$	$A^2 + 2 \cdot A \cdot B + B^2$	$(A-B)^2$	$A^2 - 2 \cdot A \cdot B + B^2$
2	31	-17	196	196	2304	2304
3	-14	-23				
4	62	-71				
5	-15	29				
6	-36	-71				
7	-18	0				
8	98	-71				
9	0	87				
10	15.2	27.1				
11	-6.91	-3.24				

[a] Verify that $(a + b)^2 = a^2 + 2ab + b^2$, by completing columns C and D.

Write the formula used in C_2

Write the formula used in D_2

[b] Verify that $(a - b)^2 = a^2 - 2ab + b^2$, by completing columns E and F.

Write the formula used in E_2

Write the formula used in F_2

[c] Extend your spreadsheet up to row 15 with numbers of your choice, and then complete columns C to F. Describe your observations.

2 [a] Using a similar table as in question 1, verify that $a^2 - b^2 = (a + b)(a - b)$.

[b] Have a copy of your work.

Unit Test

1 Complete:

[a] $(x + 5)(x + \dots) = x^2 + \dots + 15$

[b] $(2x + 1)^2 = 4x^2 + \dots$

[c] Sometimes a product of 101×99 can be found quickly by multiplying two binomials
 $(100 + 1)(\dots)$

[d] If $a = 2b$ and $b = 15$, then the numerical value of $a + 2b + 5$ is

[e] If $a + 3b = 7$, and $c = 3$, then the numerical value of $a + 3(b + c)$ is

[f] The area of the shaded region is
 square units.

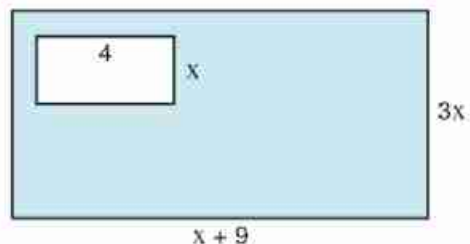

2 Circle the correct value:

[a] $3a^4 b \times 5a^2 b^2 \times 2a^3 = \dots$ [60 $a^{11} b^3$, 30 $a^{10} b^2$, 150 $a^{10} b^3$, 30 $a^9 b^3$]

[b] The cube of the sum of a and b is [$a^3 + b^3$, $(a + b)^3$, $a^3 b^3$, $3a^3 b^3$]

[c] $(4x - 3)(x - 4) = \dots$ [$4x^2 - 19x - 12$, $4x^2 - 7$, $4x^2 - 12$, $4x^2 - 19x + 12$]

[d] If the lateral area of a cube is $36x^2$, then its side length equals.....
 [9x, 9, 3x, 3]

[e] $(x - 2)(x^2 + 2x + 4) = \dots$ [$x^3 + 8$, $x^3 - 8$, $3x + 6$, $x^3 + 6$]

[f] $(x^2 + x) \div x = \dots$ [0, x, 2x + 1, x + 1]

3 [a] If $a = 3x - 4$, $b = x + 2$, and $c = 2x - 3$
 calculate the numerical value of $ab - c^2$
 when $x = 0$

[b] This figure is a rectangle made up of 4 parts, write an algebraic expression which represents the area of the rectangle.

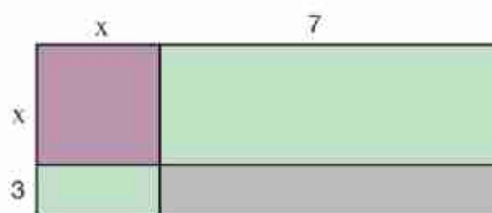

4 Write for the correct statement, and for the incorrect one:

- [a] $3x^4$ is an algebraic term of the degree 4
- [b] The algebraic terms $7x^2$, and $2x^7$ are like terms
- [c] The algebraic expression $3xy + 5$ is of the second degree.
- [d] $2x - 3y$ is the additive inverse of $3y - 2x$
- [e] $b^3 = 3 \times b \times b$
- [f] $(x + 2)^2 = x^2 + 4$

5 [a] Divide $x^3y - 4xy^2 + 6xy$ by xy
 [b] Find the result by identifying the H.C.F.

1) $17^2 - 8 \times 17 + 17$

2) $6 \times 30 + 18 \times 15 - 24 \times 15$

6 [a] Subtract $5x^2 + y^2 - 3xy$ from $x^2 - 2xy + 3y^2$
 [b] Simplify: $(7xy - 3x)^2 - (5xy - x)^2$

7 Calculate the numerical value of the following using substitution when $a = -1$, $b = 2$:

$(2a + 3b) - (3a - 2b)$

8 [a] Use Mental Math to calculate:

1) $(99.1)^2$ 2) 33×27

[b] Two metal cuboids with dimensions as shown were melted and reshaped to a new cuboid with the height $(a + b)$. Calculate the area of its base.

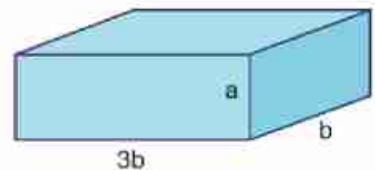
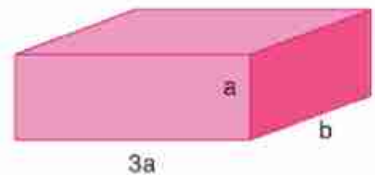

9 Find the value of K which makes:

[a] $6x^3 - 13x^2 - 13x + K$ is divisible by $3x - 5$

[b] $x^3 - 3x^2 - 25x + K$ is divisible by $x^2 + 4x + 3$

Carl Friedrich Gauss

(1777 – 1855)

The methods, theories and applications of statistics have been developed by a large number of scientists who discussed its theories and constructed them on sound scientific bases. Among those mathematicians is the German mathematician Carl Friedrich Gauss.

**Contents**Lesson **Arithmetic mean**Lesson 2 : **Median**Lesson 3 : **Mode**● **Activity.**

Measures of Central Tendency

Arithmetic mean

Median

Mode

Given the phenomena around us and the values that the different elements of these phenomena take it.

We note that most of the values of these phenomena are closed to each other, this means that they gather around a certain value for example the heights of the students of your class, we find that there is a height which mediates virtually all the heights also the weights of the students of your class and any other phenomenon and there are several statistics measures for measuring the data towards the centre (the mean, the median and the mode).

1- The Arithmetic Mean

Example:

Ahmed goes to his school from Sunday to Thursday, his father gives him pocket money as follows: 6 , 4 , 7 , 3 and 5 pounds. What is the fixed pocket money that Ahmed can take from his father such that he takes the same amount of money.

Solution:

The sum of what Ahmed take = $6 + 4 + 7 + 3 + 5 = 25$

Numbers of days for going school = 5

The daily = $\frac{25}{5} = \text{LE } 5$

The value 5 pounds is called the arithmetic mean for the values 6 , 4 , 7 , 3 , 5

This means :

The arithmetic mean = $\frac{\text{The sum of the values}}{\text{their number}}$
--

Note: In the previous Example:

We note that the arithmetic mean is that value which if Ahmed take it in the 5 days, the following satisfies:

$$5 + 5 + 5 + 5 + 5 = 6 + 4 + 7 + 3 + 5$$

Ex (2) : Find the value of x, if the arithmetic mean of the values 8 , x , 7 , 5 is 6

Solution:

The sum of the values = the arithmetic mean x their number

Then :

$$8 + x + 7 + 5 = 6 \times 4$$

$$20 + x = 24$$

Then :

$$x = 24 - 20 = \boxed{4}$$

Exercises

1- Complete :

- (a) The arithmetic mean for the values 18 , 35 , 24 , 6 is
- (b) If the arithmetic mean for the numbers 3 , 5 , x is 4 , then x =
- (c) If the sum of 5 numbers is 30, then the arithmetic mean for these numbers =

2- Find the arithmetic mean for each group of the following:

- (a) 4 , 6 (b) 3 , 5 (c) 3 , 4
- (d) 2 , 4 , 6 (e) 1 , 3 , 5 (f) 1 , 2 , 3 , 4 , 5
- (g) 6 , 10 (h) $\frac{1}{2}$, 1 (i) 10 , 20
- (j) 35 , 50 , 60 , 55

3- If the temperatures for a full week in one of the cities in December month 25° , 27° , 31° , 23° , 22° , 22° , 18° . Calculate the arithmetic mean for these degrees.

4- If the number of hours at studying for one of the students during 6 consecutive days:

The day	Saturday	Sunday	Monday	Tuesday	Wednesday
Number of studying hours	$3\frac{1}{2}$	3	$2\frac{1}{2}$	3	4

Find the mean of studying hours.

5- If the marks of Shrief in 3 consecutive months in maths test as : 89 , 91 , 96

Calculate the monthly mean for this student.

Lesson (2)

The Median

The median for a set of data is that value which lies exactly in the middle of the set after the ascendingly or descendingly of the elements of this set.

This means that the value of the median divides the given data into two parts such that the number of values greater than the median equals number of the values smaller than it.

Ex. A set of 7 students, their marks in one of the tests are 13 , 17 , 15 , 11 , 18 , 20 , 14, what is the median mark for these students.

Solution:

The order of marks (ascendingly)

11 , 13 , 14 , 15 , 17 , 18 , 20
 └───┬───┘ └───┬───┘
 ↓ ↓
 3 values 3 values

The median mark = 15

The order of the median:

- (a) If the number of the values (n) is an odd, then the order of the median is $\frac{n+1}{2}$ after the arrangement of the data ascendingly or descending in the previous example:

Number of values = 7

The order of the median = $\frac{7+1}{2} = 4$

- (b) If the number of the values is an even, then the order of the median is $\frac{n}{2}$ and the next.

i.e. $\frac{n}{2}$, $\frac{n}{2} + 1$ and the value of the median in

this case is the mean for these two values as in the example.

Find the value and the order of the median for the values

: 3 , 1 , 6 , 5 , 2 , 9.

the order is 9 , 6 , 5 , 3 , 2 , 1

The order of the median = $\frac{6}{2}$, $\frac{6}{2} + 1$

i.e. the third, fourth, the value of the median = $\frac{5+3}{2} = 4$.

Notes:

- If n is an odd (not divisible by 2), then $n + 1$ is an even, divisible by 2.
- Generally the value of the median \neq the order of the median.
- The order of the median is always positive integer but the value of the median may be fraction or negative integer according to the given data.

Exercises

1- Choose the correct answer :

- (a) If the order of the median for a set of values is the fourth, then the number of values equals (3 , 5 , 7 , 9)
- (b) If the order of the median of a set of values is the fourth, fifth, then the number of the values equals (4 , 5 , 8 , 9)
- (c) If the median for the values $a + 3$, $a + 2$, $a + 4$, where $a \in \mathbb{Z}^+$ is 8 ,
then $a =$ (2 , 3 , 4 , 5)
- (d) The median for the values 4 , 8 , 3 , 5 , 7 is (3 , 4 , 5 , 7)

2- Find the median of each group of the following:

- (a) 3 , 5 , 12 , 11 , 8
- (b) 3 , 5 , 12 , 11 , 8 , 10
- (c) $\frac{1}{2}$, $\frac{1}{4}$, 1
- (d) -2 , 0 , -1 , 1 , 5

3- The following table shows the marks of Ghad in one Maths test in 6 months.

The month	Oct.	Nov.	Dec.	Feb.	March	April
The mark	41	35	47	37	44	48

Find : (a) The median for the previous marks.

(b) The mean for the previous marks.

- The mode is the most common value in the set or in other words, it is the value which is repeated more than any other values.
- The mode as one of the central tendency measurements is available for the numerical and described values.

Example (1) : The following data represents the ages of a set of persons 33 , 20 , 30 , 25 , 33 , 48 , 33 , 25 , 33 , 20.

Find the mode for these ages.

Solution: The mode = 33

Example (2) : If the ranks of some students in one of the exams are: B – A – C – B – C – B – C – B – A – D.

Find the mode for this set.

Solution: The mode for this set is (B)

Remarks:

- If all the given values are different, then there is no mode for these values.

Example : 23 , 25 , 48 , 57 , 19 , 33 , 32 (data)

- Some values have more than one mode.

Example : 9 , 7 , 7 , 7 , 5 , 5 , 4 , 4 , 4 , 3 , 2 there is two modes for this set of values which are 7 and 4 (set of two modes) (we will study the data with only one mode)

Exercises

1- Complete the following:

- (a) The mode for the set of values: 14 , 11 , 12 , 11 , 14 , 15 and 11 is
- (b) The mode for the colors: red, yellow, red, white, black, red and white is
- (c) If the mode for the values 15 , 9 , $x + 1$, 9 , 15 is 9 , then $x =$

2- Choose the correct answer:

- (a) The mode for the values 1 , 3 , 7 , 3 , 6 , 7 and 3 is [1 , 3 , 6 , 7]
- (b) If the mode for the following set of values 7 , 5 , $y + 3$, 5 and 7 is 7, then $y =$
[3 , 4 , 5 , 7]

3- Find the mean, median and the mode for the following values:

5 , 4 , 10 , 3 , 3 , 4 , 7 , 4 , 6 , 5

The activity of the unit

(1) Which of the following numbers is the arithmetic mean for the other values?

- (a) 26 (b) 28 (c) 29 (d) 30 (e) 37

(2) If the mean of Karem's marks in 5 tests is 84, the mean of his marks in the first three tests is 80, then what is the mean of his marks in the last 2 tests?

(3) Calculate the mean and the median for each set of the following sets of numbers:

(a) 1 , 2 , 3 , , 8 , 9 , 10

(b) 1 , 2 , 3 , , 9 , 10 , 11

(c) 1 , 2 , 3 , 99 , 100

(d) 1 , 2 , 3 , , 100 , 101

(e) 0 , 2 , 4 , 6 , 8 , 10

(f) 1 , 3 , 5 , , 99

* Does each of the previous sets have a mode or not?

Euclid**(325 BC - 265 BC)**

Euclid is a Greek Mathematician Scientist, He lived in Alexandria, is considered the father of Geometry, he said that "What made without evidence can be refused without evidence"

Definitions:

The point is what it is not part.

The straight line has neither length nor width.

Some axioms:

A straight line segment can be drawn by joining any two points.

A straight line segment can be extended indefinitely in a straight line.

All right angles are equal.

**CONTENTS**

Lesson 1 Geometric Concepts.

Lesson 2 Congruence

Lesson 3 Congruent triangles

Lesson 4 Parallels

Lesson 5 Geometric constructions

● Unit test

The line segment

Mark two points on a sheet of paper which is a representation of a **plane** in geometry.

If we join them with a straight edge, we have a line segment. The two points we joined are called end points. If we name these two points A and B, we get a line segment AB is written as \overline{AB} or \overline{BA} .

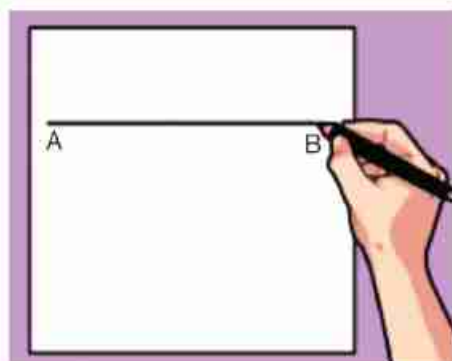

The straight line

If we extend the line segment AB in both directions indefinitely, we will get what we call, in geometry, a straight line. A straight line AB, written as \overleftrightarrow{AB} , or \overleftrightarrow{BA} .

There is an infinite number of points on the straight line, the arrows show that the line can be extended without limit on both sides

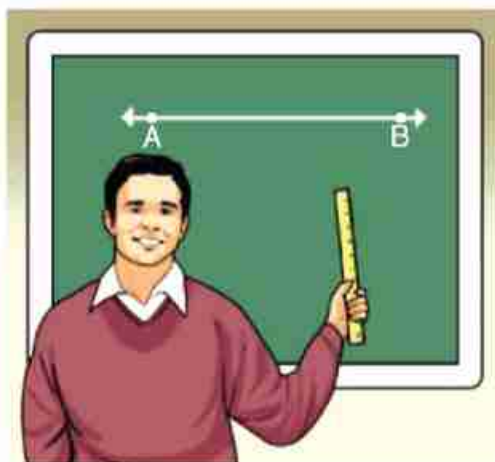

The ray

If we extend the line segment AB in either direction indefinitely, we will get a ray AB, or a ray BA.

Ray AB is written as \overrightarrow{AB} , where the ray starts at A and continuous without end from A through B in a straight line so it is infinitely long. Thus its length is not determined.

Then: $\overleftrightarrow{AB} \subset \overleftrightarrow{AB}$, $\overleftrightarrow{AB} \subset \overleftrightarrow{AB}$, $\overleftrightarrow{BA} \subset \overleftrightarrow{AB}$



The angle

We can view an angle as the rotation of a ray from one position to another around the starting point.

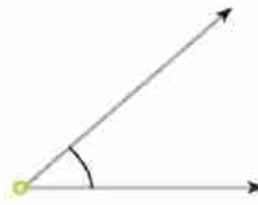

If A, B and C are three non-collinear points then \vec{AB} , \vec{AC} form the angle BAC and is written as $\angle BAC$, $\vec{AB} \cup \vec{AC} = \angle BAC$

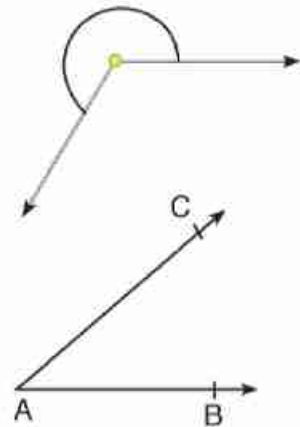

The angle is the union of two rays with the same starting point.

The common point of the two rays is called the vertex of the angle.

Each of the two rays is called a side of the angle.

The angle divides its plane into three sets of points which are:

- The angle.
- The interior of the angle.
- The exterior of the angle.



Types of angles

Angles are classified according to their measures as follows:

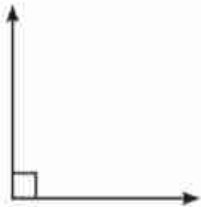

An angle of 90° is called a **right angle**

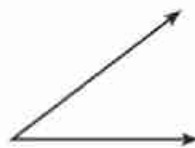

An angle of less than 90° But is greater than 0° is called an **acute angle**

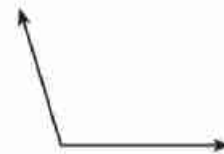

An angle of greater than 90° but less than 180° is called an **obtuse angle**



a straight angle is an angle whose measure is 180°

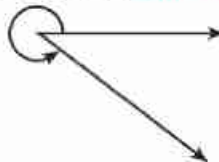

An angle that is greater than 180° but less than 360° is called a **reflex angle**



Zero angle is an angle whose measure is zero, where its sides are coincident

Some relations between the angles

Adjacent angles

Two angles are said to be adjacent if they have a common vertex, a common side and the other two sides are on opposite sides of the common side.

$\angle ABD$, $\angle DBC$ are adjacent

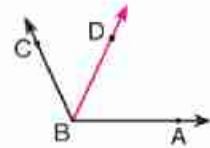

Notice that:

1

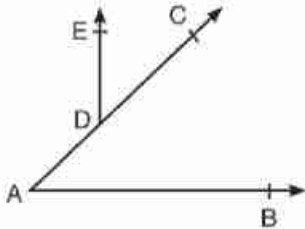

$\angle BAC$ and $\angle EDC$
are not adjacent because
they have not a common vertex

2

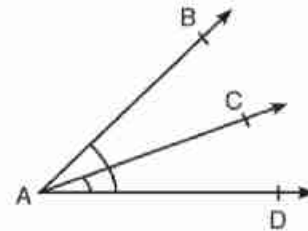

$\angle BAC$ and $\angle BAD$ are not
adjacent because the sides
 \overrightarrow{AC} and \overrightarrow{AD} are not on the
opposite sides of \overrightarrow{AB}

Complementary angles

Suppose we are given two pairs of angles,
 25° , 65° and 70° , 20° .

What do you notice about the sum of each
pair of angles?

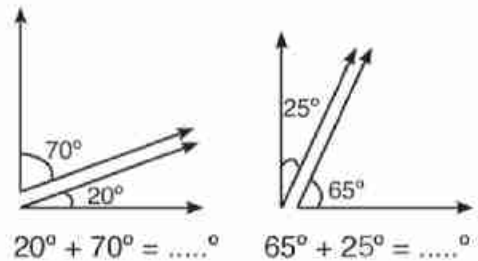

Two angles are said to be complementary if their sum is 90° .

Supplementary angles

We are given two pairs of angles, 125° , 55°
and 151° , 29° .

What do you notice about the sum of each
pair of angles?

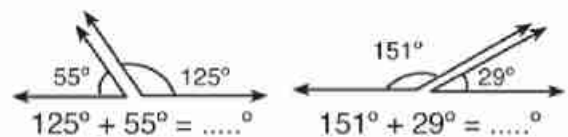

Two adjacent angles formed by a straight line and a ray with a starting point on this straight line are supplementary



$$m(\angle BAC) + m(\angle CAD) = 180^\circ$$

Dirll

1 In each of the following figures:

If $A \in \overleftrightarrow{BC}$, then complete:

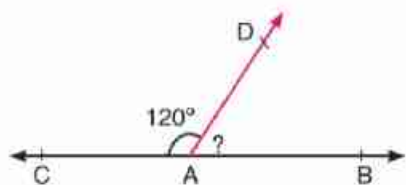

$$m(\angle BAD) = \dots^\circ$$

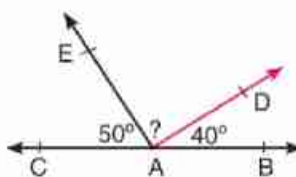

$$m(\angle DAE) = \dots^\circ$$

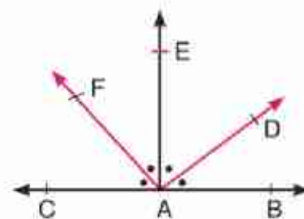

$$m(\angle BAD) = \dots^\circ$$

2 Draw the two adjacent angles BAD and DAC such that the sum of their measures is 180° . Repeat this work, what is the relation between \overrightarrow{AB} and \overrightarrow{AC} ?

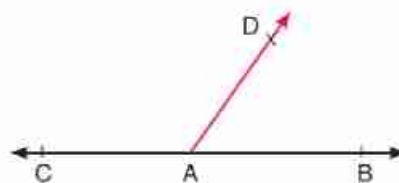

If two adjacent angles are supplementary then their outer sides are on the same straight line.

\overrightarrow{AB} and \overrightarrow{AC} are on the same straight line.

Example (1)

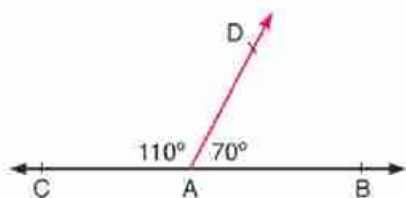

\vec{AB} and \vec{AC} are on the straight line because
 $m(\angle BAC) + m(\angle DAC) = 180^\circ$

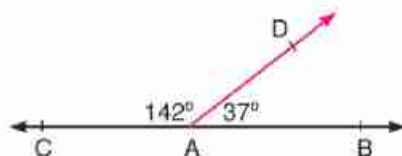

\vec{AB} and \vec{AC} are not on the same straight line because
 $m(\angle BAD) + m(\angle DAC) \neq 180^\circ$

vertically opposite angles

Draw \vec{AB} and \vec{CD} to intersect at M, then measure the angles: AMC, CMB, BMD, and DMA
what do you notice?

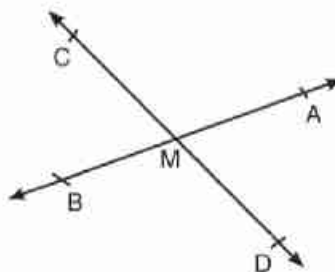

If two straight lines intersect, then the measures of each two vertically opposite angles are equal.

Accumulative angles at a point

From the point M, Draw \vec{MA} , \vec{MB} , \vec{MC} , \vec{MD} , then measure the resulted adjacent angles.
 $m(\angle AMB) + m(\angle BMC) + m(\angle CMD) + m(\angle DMA) = \dots$
Repeat this work, what do you notice?

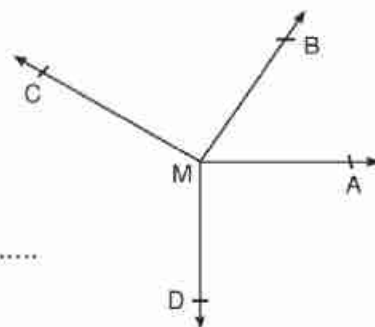

The sum of the measures of the accumulative angles at a point is 360°

Angle bisector

An angle bisector is a ray that divides an angle into two halves.

\overrightarrow{OP} divides $\angle AOB$ into two angles having the same measure and \overrightarrow{OP} is called the bisector of $\angle AOB$.

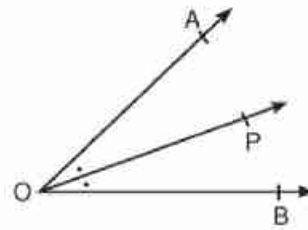

Example (2)

In the figure opposite,

M is the point of intersection of \overleftrightarrow{AB} and \overleftrightarrow{CD} , \overrightarrow{ME} bisects $\angle AMC$, and $m(\angle BMC) = 116^\circ$

Find: $m(\angle AMC)$, $m(\angle AMD)$, and $m(\angle AME)$

Solution:

$$m(\angle AMC) = 180^\circ - 116^\circ = 64^\circ$$

$$m(\angle AMD) = m(\angle CMB) = 116^\circ \text{ v. opp. angles}$$

$$m(\angle AME) = \frac{1}{2} m(\angle AMC) = \frac{64^\circ}{2} = 32^\circ$$

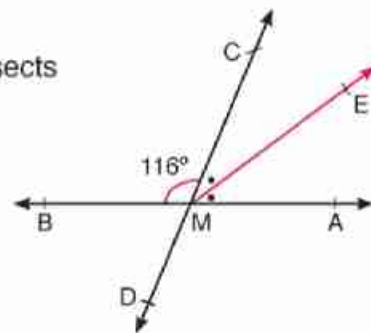

Example (3)

In the figure opposite,

Complete:

(1) $m(\angle CMD) = \dots^\circ$

(2) \dots and \dots lie on the same straight line.

Solution:

(1) $m(\angle CMD) = 360^\circ - (50^\circ + 130^\circ + 75^\circ) = 105^\circ$

(2) \overrightarrow{MA} and \overrightarrow{MC} lie on the same straight line

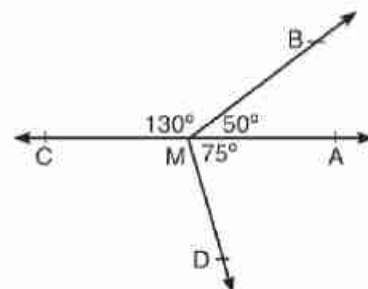

Exercise (4-2)

1 Complete:

- [a] If $m(\angle A) = 80^\circ$ then $m(\text{reflex } \angle A) = \dots^\circ$
 [b] The measure of each of two equal complementary angles equals \dots°
 [c] If $\angle A$ and $\angle B$ are supplementary angles and
 $m(\angle A) = 2 m(\angle B)$ then $m(\angle B) = \dots^\circ$

2 Draw an angle PQR:

- [a] Measure $\angle PQR$.
 [b] Draw ray \overrightarrow{QS} between \overrightarrow{QR} and \overrightarrow{QP} such that $m(\angle SQR) = \frac{1}{2} m(\angle PQR)$.
 [c] Does \overrightarrow{QS} bisect $\angle PQR$? [d] Produce \overrightarrow{RQ} to T .
 [e] Draw the bisector \overrightarrow{QU} of $\angle PQT$
 Measure the angles first before answering (f) and (g).
 [f] Name all pairs of complementary angles.
 [g] Name all pairs of supplementary angles.

3 [a] Use your protractor to draw angles which have the values

- [a] 60° [b] 115° [c] 195° [d] 245°

Classify the angles into acute, obtuse and reflex angles.

[b] What are the supplements of the angles whose measures are?

- [a] 10° [b] 117° [c] 82° [d] $92\frac{1}{2}^\circ$

[c] What are the complements of the angles whose measures are?

- [a] 37° [b] 48° [c] 45° [d] $22\frac{1}{2}^\circ$

4 In the figure opposite,

If $B \in \overleftrightarrow{AC}$, $m(\angle DBC) = 135^\circ$ and

\overrightarrow{BA} bisects $\angle DBE$ find:

$m(\angle ABD)$, $m(\angle DBE)$, $m(\angle CBE)$

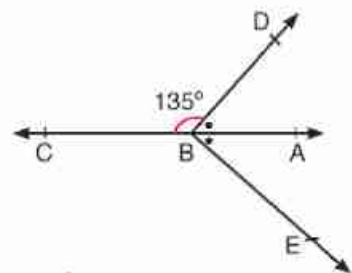

5 In the figure opposite,

If $\overleftrightarrow{AB} \cap \overleftrightarrow{CE} = \{M\}$,

$MD \perp CE$ and MB bisects

$\angle DME$ find:

$m(\angle BME)$, $m(\angle DME)$,

$m(\angle AMC)$ and $m(\angle AME)$

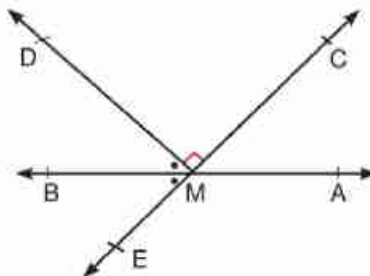

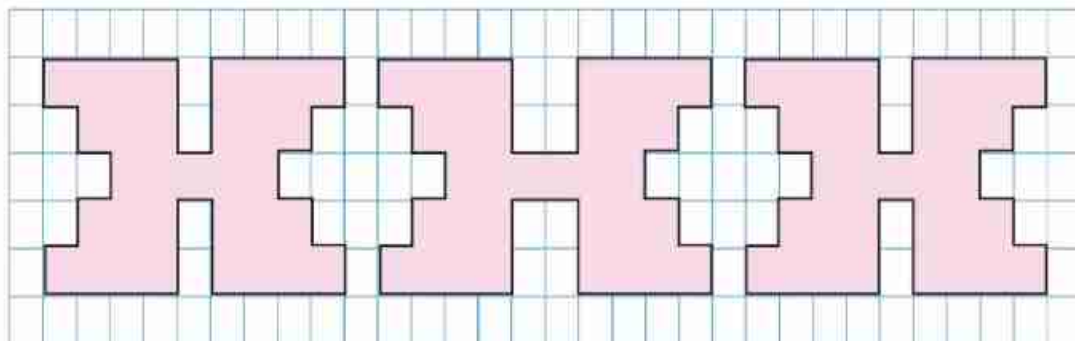

figure (1)

figure (2)

figure (3)

Using the design shown above,

Complete the following:

If you trace the figure, you will find figures,

have the same size and shape, but the figure is slightly wider.

Two figures are congruent if there is a correspondence between the vertices such that each side and each vertex of one coincides with the corresponding element of the other.

Two line segments are congruent if they have the same length.

Two angles are congruent if they have the same measure.

- The polygon BRAKE is congruent to the polygon CHOKE, the vertices are written in the same order.

Complete:

$CH = \dots$, $EK = \dots$

$HO = \dots$, $EC = \dots$

$KO = \dots$, \overline{KE} is a common side

$m(\angle C) = m(\angle \dots)$, $m(\angle OKE) = m(\angle \dots)$

$m(\angle H) = m(\angle \dots)$, $m(\angle KEC) = m(\angle \dots)$

$m(\angle O) = m(\angle \dots)$

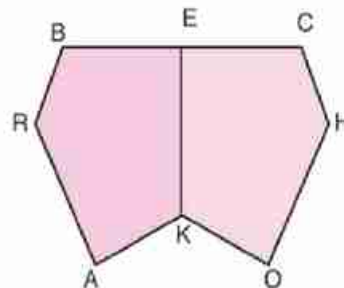

Exercise (4-2)

- 1 In the Figure: there is one leaf differs from the others. Which one is different and how?

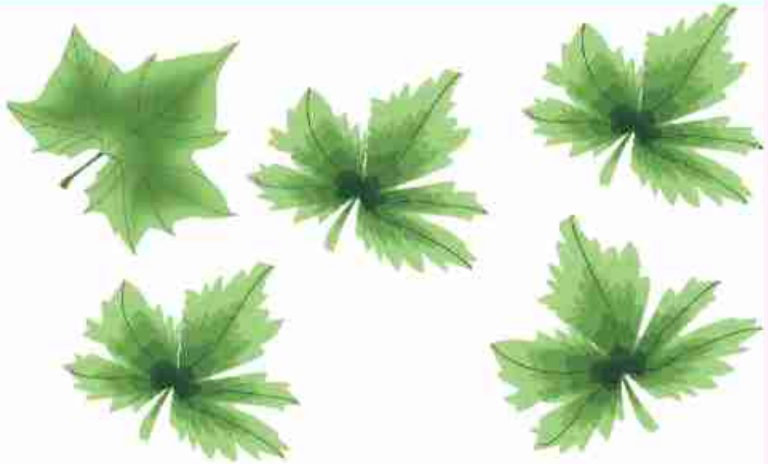

- 2 The two pentagons shown are congruent.

Complete

- [a] B Corresponds to
- [b] The polygon BLACK is congruent to the polygon.....
- [c] KB = cm.
- [d] $m(\angle E) = m(\angle \dots)$
- [e] CA =
- [f] $m(\angle A) = m(\angle \dots)$

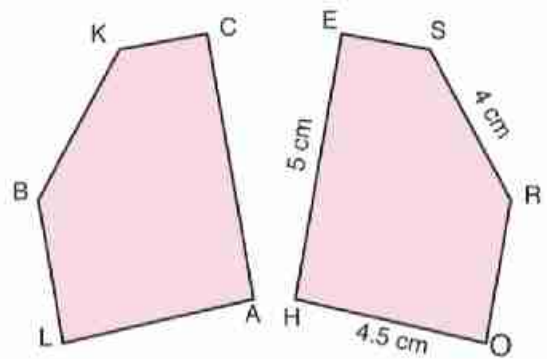

- 3 In the figure opposite.

\overleftrightarrow{OR} is the axis of symmetry of NERAM,
 $O \in \overline{NM}$

[a] **Complete.**

- The quadrilateral NERO is congruent to the quadrilateral
- The common side of the two congruent quadrilaterals is

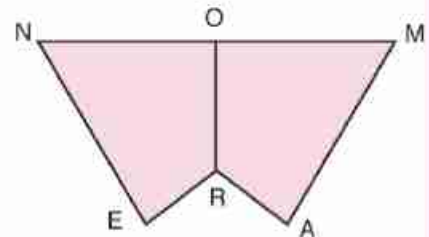

- [b] In your own words explain why each of the following statements must be true.

1. O is the mid-point of \overline{NM} .
2. $\angle NOR$ is congruent to $\angle MOR$.
3. $\overline{RO} \perp \overline{NM}$
4. \overline{OR} in the polygon MARO is congruent to \overline{OR} in the polygon NERO.

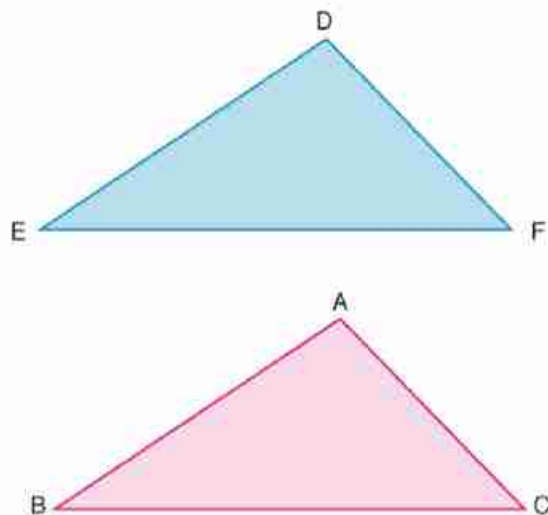

We know that any triangle has three sides and three angles, which are known as the six elements of the triangle.

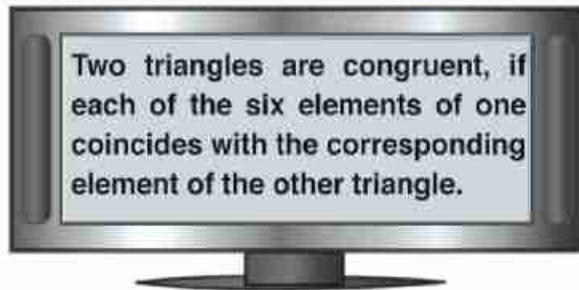

We can usually decide whether two triangles are congruent by placing $\triangle ABC$ on top of $\triangle DEF$ to see if they fit (Sometimes we may have to flip one of the triangles over).

The vertices like will watch:

$$A \longleftrightarrow D \qquad B \longleftrightarrow E \qquad C \longleftrightarrow F$$

The sides and angles will also match:

Corresponding angles

$$\begin{aligned} \angle A &\longleftrightarrow \angle D \\ \angle B &\longleftrightarrow \angle E \\ \angle C &\longleftrightarrow \angle F \end{aligned}$$

Corresponding sides

$$\begin{aligned} \overline{AB} &\longleftrightarrow \overline{DE} \\ \overline{BC} &\longleftrightarrow \overline{EF} \\ \overline{AC} &\longleftrightarrow \overline{DF} \end{aligned}$$

The symbol " \equiv " is used as a short form for "is congruent to" thus $\triangle ABC \equiv \triangle DEF$ is read as triangle ABC is congruent to triangle DEF.

A simple way to remember the correspondence is shown below.

$\triangle ABC \equiv \triangle DEF$

We should not write $\triangle ABC \equiv \triangle DEF$
 We can write $\triangle BCA \equiv \triangle EFD$

$\triangle CAB \equiv \triangle FDE$

⋮ ⋮

Congruent Triangles

- To test whether two triangles are congruent, or not you don't need to test all the three sides and the three angles.
- Instead of using your geometrical instruments, you can draw and measure figures on your computer to help you discover some rules about congruent triangles.

Activity 1:

- ★ Draw any $\triangle ABC$ and $\triangle DEF$ such that:
 $m(\angle FDE) = m(\angle CAB)$, $DE = AB$ and $DF = AC$.
 Measure \overline{BC} , \overline{EF} , $\angle ABC$ and $\angle DEF$,
 What do you notice?

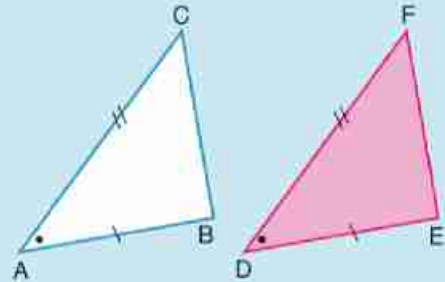

- Vary $\triangle ABC$ and $\triangle DEF$ (Make sure that the above three given conditions are satisfied.)
 Move $\triangle DEF$ and check whether it falls exactly onto $\triangle ABC$.
 Is this sufficient so as $\triangle ABC \cong \triangle DEF$?

- The first case.

Two sides and the Included Angle' test (SAS).

Two triangles are congruent if two sides and the included angle of one triangle are congruent to the corresponding parts of the other triangle.

Example

In the figure opposite,

$\overline{AB} \cap \overline{CD} = \{M\}$, $AM = BM$, and $CM = DM$.
 Does $\triangle AMC \cong \triangle BMD$? why?

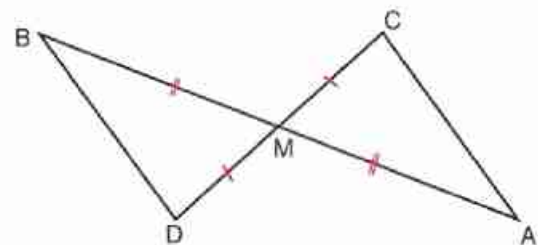

Solution:

from the figure: $AM = BM$, $CM = DM$,
 $m(\angle AMC) = m(\angle BMD)$ v.opp. angles
 then $\triangle AMC \cong \triangle BMD$

Activity 2:

- * Draw any $\triangle ABC$ and $\triangle DEF$ such that:

$$AB = DE$$

$$m(\angle CAB) = m(\angle FDE) \text{ and}$$

$$m(\angle CBA) = m(\angle FED).$$

Measure \overline{AC} , \overline{DF} , \overline{BC} , \overline{EF} ,

$\angle ACB$ and $\angle DFE$.

What do you notice?

- Vary $\triangle ABC$ and $\triangle DEF$ without changing the above conditions.
Move $\triangle DEF$ and check whether it falls exactly onto $\triangle ABC$.

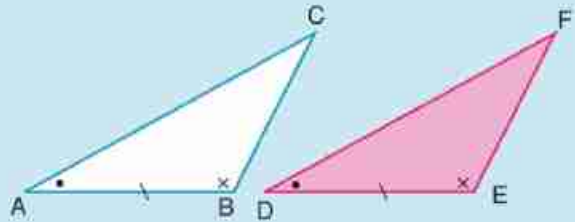

- The second case.

Two angles and a corresponding side' test (ASA).

Two triangles are congruent if two angles and the side drawn between their vertices of one triangle are congruent to the corresponding parts of the other triangle.

Dirll

In the figure opposite,

Complete:

$$\triangle ABC \cong \dots$$

Why?

From the results of congruency:

$$m(\angle A) = m(\angle \dots),$$

$$AB = \dots,$$

$$\dots = BD$$

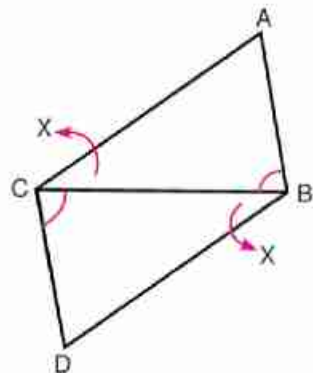

Activity 3:

- * Draw any $\triangle ABC$ and $\triangle DEF$ such that $AB = DE$, $DF = AC$ and $EF = BC$. Measure $\angle CAB$, $\angle FDE$, $\angle ABC$, $\angle DEF$, $\angle ACB$ and $\angle DFE$. What do you notice?

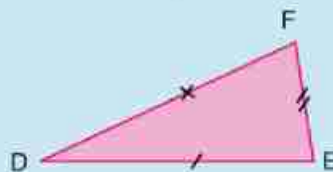

- Vary $\triangle ABC$ and $\triangle DEF$ (Make sure that the above three given conditions are satisfied.)

Move $\triangle DEF$ and check whether it falls exactly onto $\triangle ABC$.

Is this sufficient so as $\triangle ABC \cong \triangle DEF$?

- The third case.

Side-Side-Side' test (SSS).

Two triangles are congruent if each side of one triangle is congruent to the corresponding side of the other triangle.

Example

In the figure opposite,
 $AB = AC$, $BD = CD$
verify that: \overrightarrow{AD} bisects $\angle A$

Solution:

$\triangle ABD \cong \triangle ACD$ (sss)
From the results of congruency
then $m(\angle BAD) = m(\angle CAD)$
i.e \overrightarrow{AD} bisects $\angle A$

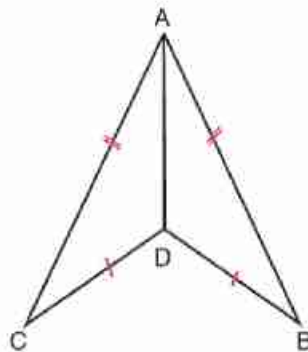

Activity 4:

- ★ Draw any $\triangle ABC$ right-angled at B and $\triangle FDE$, such that $m(\angle D) = m(\angle B)$, $FE = CA$ and $ED = BC$. Measure \overline{AB} , \overline{FD} , $\angle CAB$, $\angle EFD$, $\angle ACB$ and $\angle FED$.

What do you notice?

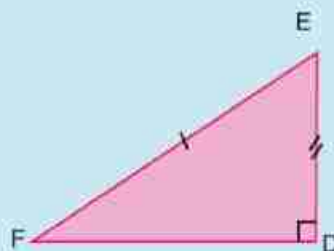

- Vary $\triangle ABC$ and $\triangle DEF$ without changing the above conditions. Move $\triangle DEF$ and check whether it falls exactly onto $\triangle ABC$. Is this sufficient so as $\triangle ABC \equiv \triangle DEF$?

- The forth case.

Right angle, Hypotenuse and side' test (RHS)

Two right-angled triangles are congruent if the hypotenuse and a side of one triangle are congruent to the Corresponding parts of the other triangle.

Example

In the figure opposite, Study the case of congruency then deduce: $m(\angle AED)$, length of \overline{AD}

Solution:

$$\triangle ABC \equiv \triangle EDA \text{ (RHS)}$$

From the results of congruency

$$\text{then } m(\angle AED) = m(\angle CAB) = 56^\circ$$

$$AD = CB = 5 \text{ cm}$$

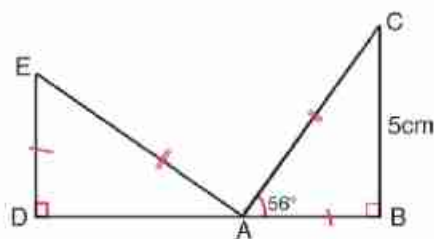

Diril

In the figures below, the similar signs denote the congruency of the elements marked by these signs.

Mention the pairs of congruent and non congruent triangles (give reason).

[1]

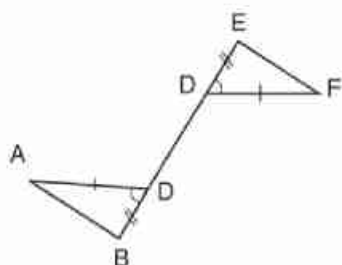

[5]

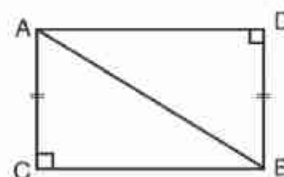

[2]

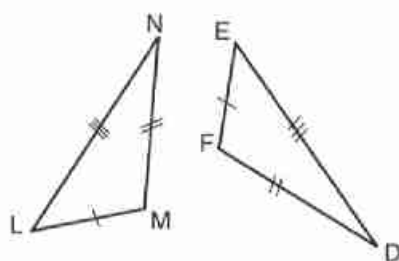

[6]

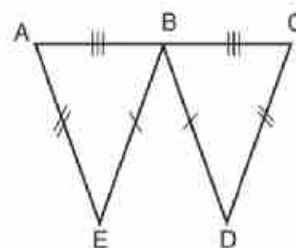

[3]

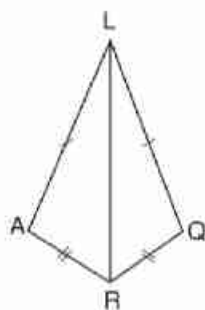

[7]

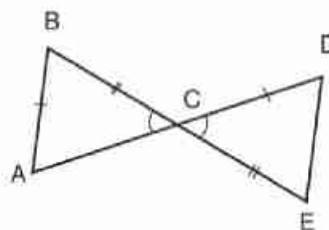

[4]

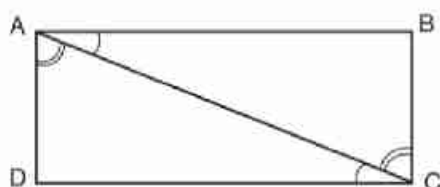

[8]

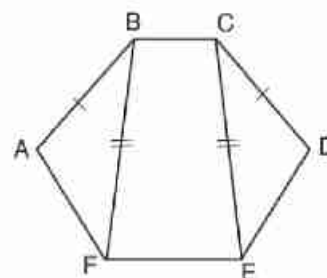

Exercise (4-3)

1 The similar signs denote the congruency of the elements marked by these signs.

- Are the triangles congruent?
- Write a correct statement of congruence and state the test used.

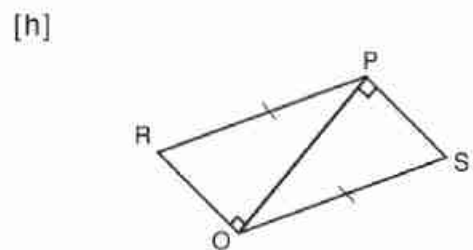
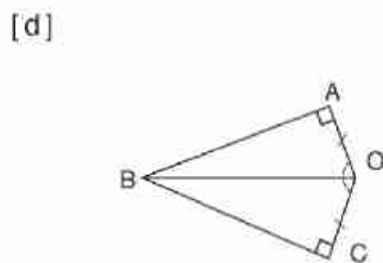
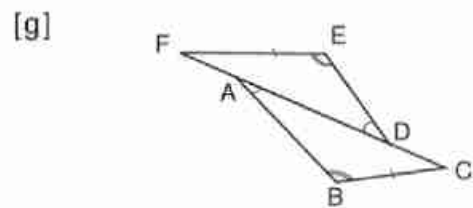
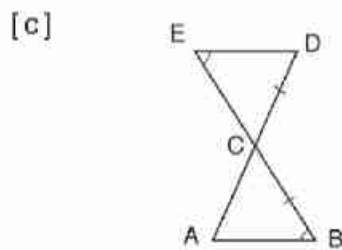
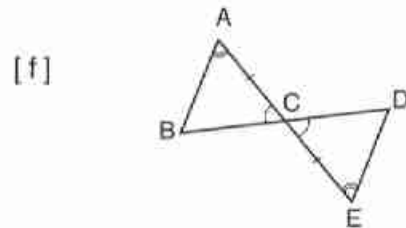
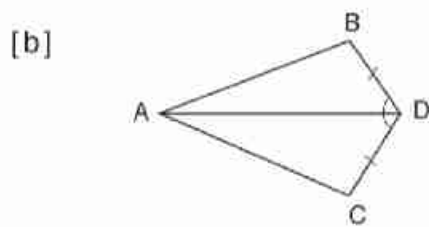
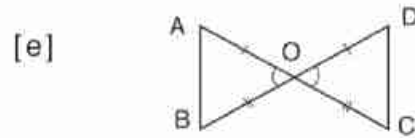
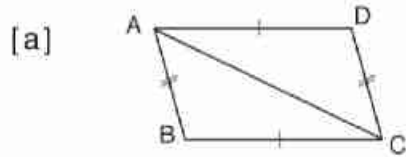

2 Study these figures and calculate the values of x and y .

[a]

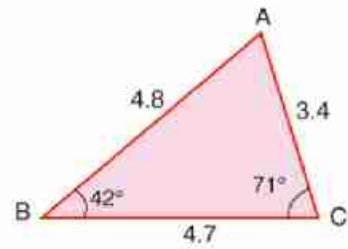
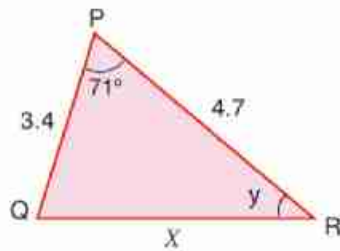

[b]

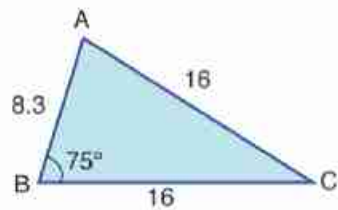
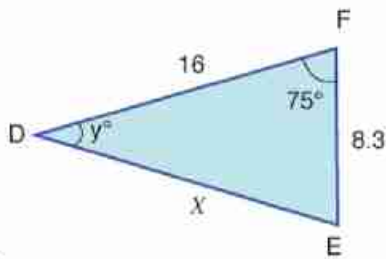

[c]

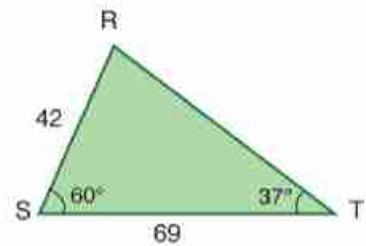
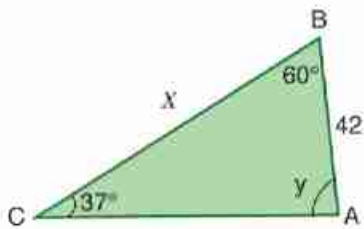

[d]

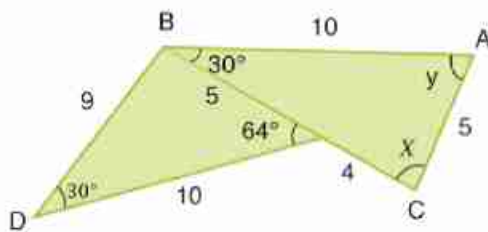

[e]

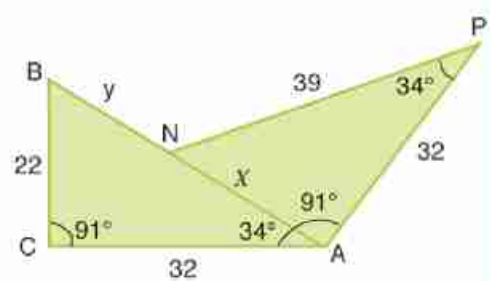

- 3** The similar signs denote the congruency of the elements marked by these signs. Find the two congruent triangles, give reasons, and write down the results of congruence.

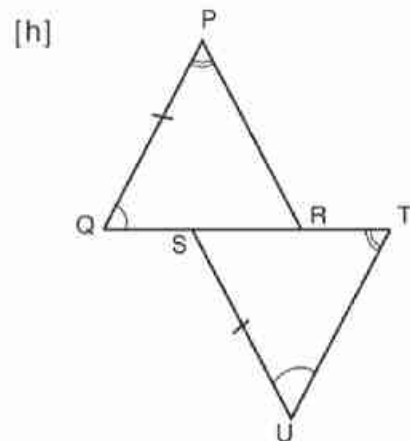
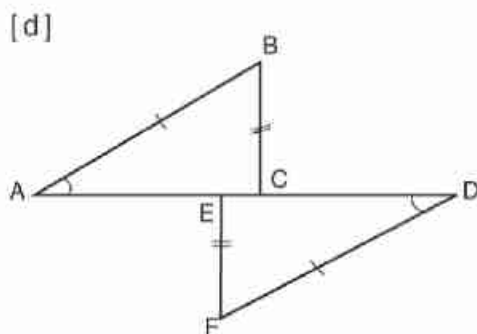
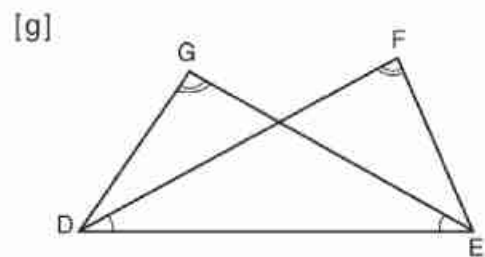
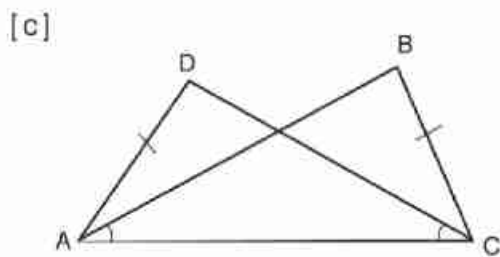
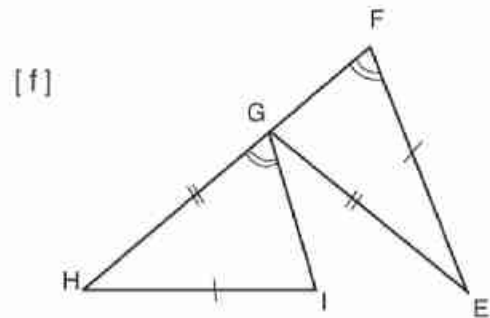
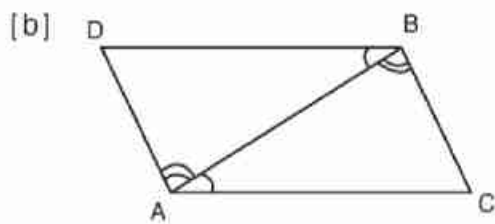
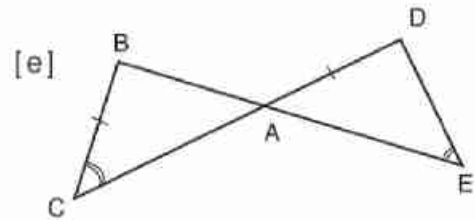
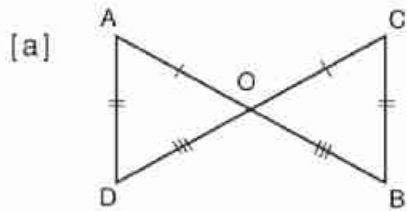

4 Study the data for $\triangle ABC$ and $\triangle XPG$. Are these triangles congruent? Write, if applicable, a correct statement of congruence and state the test used.

[a] $AB = PX, AC = XG, \angle A \equiv \angle X$

[b] $BC = PG, BA = XP, \angle B \equiv \angle G$

[c] $AB = PG, BC = PX, AC = XG$

[d] $AB = XP, CA = GX, \angle B \equiv \angle P$

[e] $\angle B \equiv \angle G, \angle C \equiv \angle X, BC = XG$

[f] $\angle A \equiv \angle X, \angle B \equiv \angle P, AC = PG$

5 Mark (\checkmark) for the correct statement:

[a] Two triangles are congruent if the lengths of sides of one triangle are equal to the corresponding parts of the other.

[b] Two triangles are congruent if the measures of the angles of one triangle are equal to the measures of the corresponding parts of the other.

[c] Two right-angled triangles are congruent if the lengths of two sides of one triangle are equal to the corresponding parts of the other triangle.

[d] Two right-angled triangles are congruent if the length of the hypotenuse and the measure of an angle differs from the right angle are equal to the corresponding parts of the other triangle.

[e] Two right-angled triangles are congruent if the length of the hypotenuse and the length of a side of one triangle are equal to the corresponding parts of the other triangle.

6 [a] Use a protractor to draw a triangle whose angles have measure 50° , 60° , and 70° .

[b] Can you draw another triangle whose angles have measures 50° , 60° , and 70° but which is not congruent to the first triangle?

Draw two straight lines L and M, then draw a transversal N (a line that intersect them both).

Pairs of alternate, corresponding and interior angles are formed.

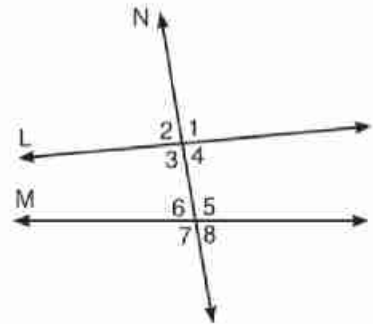

Activities

1 Complete:

$\angle 3$ and $\angle 5$ are called alternate angles

$\angle \dots$ and $\angle \dots$ are called alternate angles

In case of L is parallel to M, Notice the relation between the alternate angles.

2 $\angle 1$ and $\angle 5$ are called corresponding angles.

$\angle \dots$ and $\angle \dots$ are called corresponding angles.

Determine two more pairs of corresponding angles.

In case of L is parallel to M, notice the relation between the corresponding angles.

3 $\angle 4$ and $\angle 5$ are called interior angles on one side of the transversal, $\angle \dots$ and $\angle \dots$ are called interior angles on one side of the transversal.

In case of L is parallel to M, Notice the sum of two interior angles on one side of the transversal.

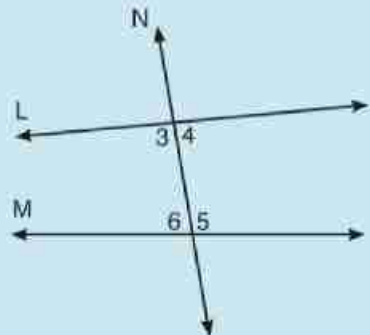
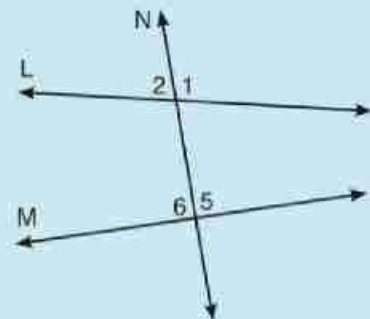
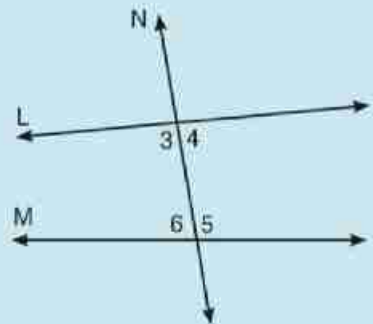

Use your computer or geometrical instruments to carry out the following activities.

Activity 1

From a point C which is not on \overleftrightarrow{AB} ,
draw $CD \parallel \overleftrightarrow{AB}$, draw EF a transversal to
intersect CD and AB at X and Y respectively,
determine:

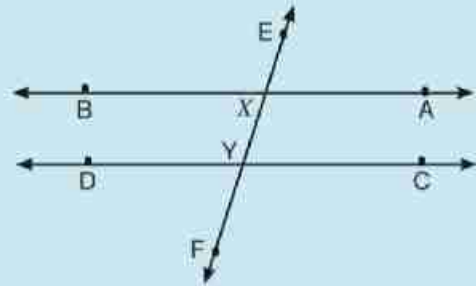

- The measures of two alternate angles.
- The measures of two corresponding angles.
- The measures of two interior angles on one side of the transversal, then add them vary the position of the transversal \overleftrightarrow{EF} . What do you notice?

• If a straight line intersects two parallel straight lines, then:

- Every two alternate angles are equal in measure.
- Every two corresponding angles are equal in measure.
- Every two interior angles on one side of the transversal are supplementary.

Drill

In each of the following figures, if $\overleftrightarrow{AB} \parallel \overleftrightarrow{CD}$, then complete:

[1]

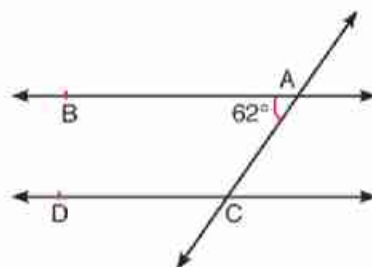

$$m(\angle ACD) = \dots^\circ - \dots^\circ \\ = \dots^\circ$$

[2]

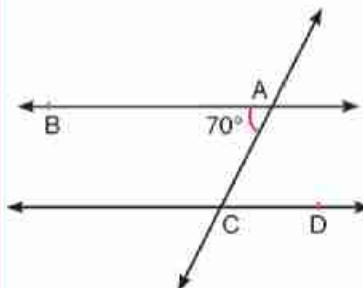

$$m(\angle ACD) = m(\angle \dots) \\ = \dots^\circ$$

[3]

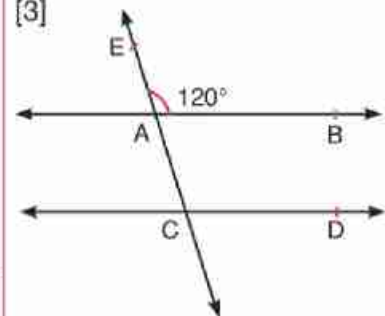

$$m(\angle ACD) = m(\angle \dots) \\ = \dots^\circ$$

Activity 2

[a] Draw \overleftrightarrow{AB} and \overleftrightarrow{CD} , then draw the transversal \overleftrightarrow{EF} to intersect them at X and Y respectively, determine:

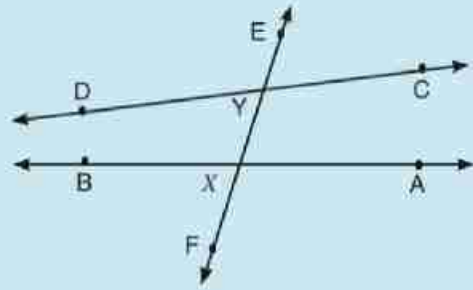

The measures of the two alternate angles $\angle CYX$ and $\angle BXY$

Rotate \overleftrightarrow{CD} about Y until $m(\angle CYX) = m(\angle BXY)$. Test whether \overleftrightarrow{CD} is parallel to \overleftrightarrow{AB} by drawing \overleftrightarrow{MN} passes through Y and is parallel to \overleftrightarrow{AB} .

Does \overleftrightarrow{MN} coincide with \overleftrightarrow{CD} ?

Determine once again the measure of the alternate angles $\angle CYX$ and $\angle BXY$

[b] Carryout similar activities as in [a] about:

- [1] corresponding angles.
- [2] interior angles on the same side of the transversal.

What do you notice?

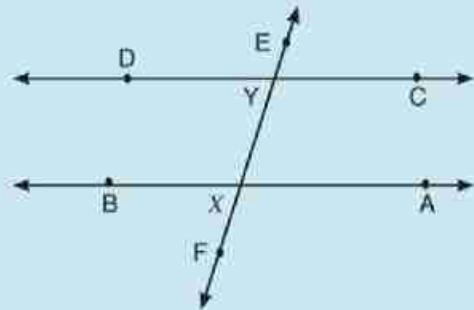

• Two straight lines in a plane are parallel if they are cut by a transversal in such a way that:

- The alternate angles are equal in measure.
- The corresponding angles are equal in measure.
- The interior angles on one side of the transversal are supplementary.

Example

In the figure opposite,

If $\overrightarrow{AB} \parallel \overrightarrow{CD}$,

Does $\overrightarrow{AC} \parallel \overrightarrow{DE}$? why?

Solution:

$m(\angle C) = 180^\circ - 115^\circ = 65^\circ$ because

i.e $m(\angle C) = m(\angle D) = 65^\circ$

then $\overrightarrow{AC} \parallel \overrightarrow{DE}$

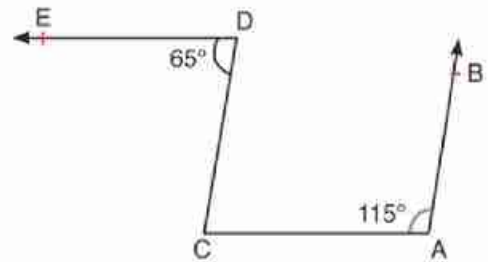

Drill

In the figure opposite,

$\overrightarrow{AB} \parallel \overrightarrow{CD}$, $\overrightarrow{EF} \parallel \overrightarrow{CD}$,

$m(\angle A) = 42^\circ$, and $m(\angle C) = 117^\circ$

Determine $m(\angle AEC)$

Solution:

$m(\angle AEC) = m(\angle A) + m(\angle \dots)$

$= \dots^\circ + \dots^\circ$

$= \dots^\circ$

Because

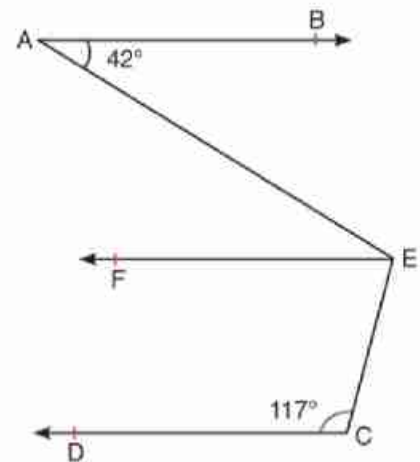

Activity 3

Draw a straight line AB and mark a point C which is not on AB , draw $CD \parallel AB$ and a straight line through C perpendicular to AB

intersecting AB at E . Measure $\angle DCE$.

Name the relationship between CD and CE .

Vary the position of CE and CD .

What do you notice?

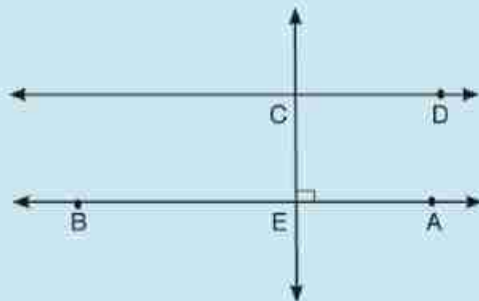

- A straight line that is perpendicular to one of two parallel lines is also perpendicular to the other.
- If each one of two straight lines is perpendicular to a third line in a plane, then the two straight lines are parallel.

Activity 4

Draw $AB \parallel CD$, then draw $EF \parallel AB$, then draw $EX \perp CD$ and intersects it at X .

Measure $\angle FEX$

Is EF also parallel to CD ? Give your reasons

Vary the position of EX and CD .

What do you notice?

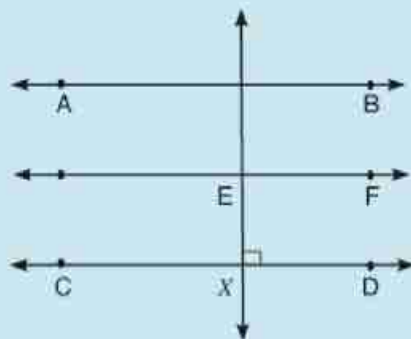

- If two straight lines are parallel to a third straight line, then these two straight lines are parallel to each other.

Activity 5

Draw several parallel lines L_1, L_2, L_3, L_4 , then draw the transversal M_1 , intersect them at A, B, C, and D respectively where $AB = BC = CD$. Draw the transversal M_2 to intersect them at E, F, G, and H

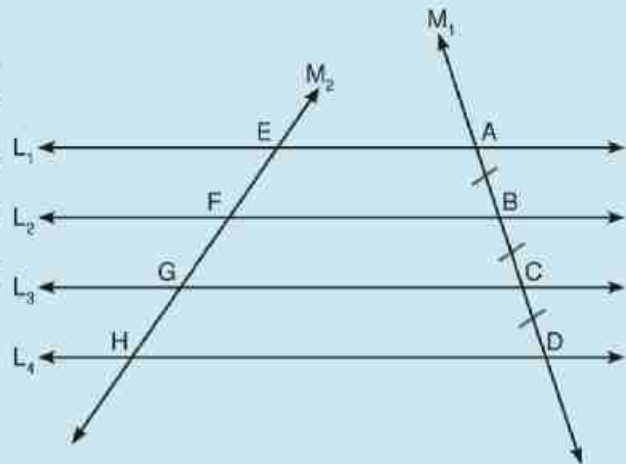

Does $EF = FG = GH$?

What do you notice?

Vary the position of the transversal M_2 , what do you notice?

- If Parallel straight lines divide a straight line into segments of equal lengths, then they divide any other straight line into segments of equal lengths

Drill

In the figure opposite,

$$\overleftrightarrow{AF} \parallel \overleftrightarrow{DX}, \quad \overleftrightarrow{EY} \parallel \overleftrightarrow{BC},$$

$$AX = XY = YC \text{ and } AB = 12 \text{ cm}$$

Find the length of \overline{BE}

Solution:

$$\overleftrightarrow{AF} \parallel \dots \parallel \dots \parallel \dots,$$

$$AX = \dots = \dots$$

$$\text{Then } AD = DE = EB$$

$$\text{i.e. } BE = \frac{1}{3} AB = 4 \text{ cm}$$

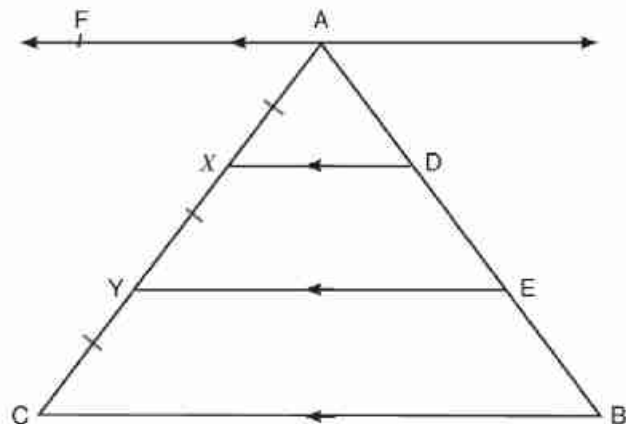

Exercise (4-4):

1 Complete:

- [a] A straight line that is perpendicular to one of two parallel lines is also to the other.
- [b] A straight line that is parallel to one two parallel lines is also to the other.
- [c] When a transversal cuts two parallel lines,
- [1] The alternate angles are
 - [2] The corresponding angles are
 - [3] The interior angles on the same side of the transversal are
- [d] Two straight lines in a plane are parallel if they are cut by a transversal in such a way that
- [1] The angles are equal, or
 - [2] The angles are equal, or
 - [3] The angles on the same side of the transversal are supplementary.
- [e] If two straight lines intersect, then the measure of each two vertically opposite angles are.....
- [f] In this figure, if $\overline{CD} \parallel \overline{BA}$ and $\overline{DE} \parallel \overline{CB}$. then $x = \dots\dots^\circ$

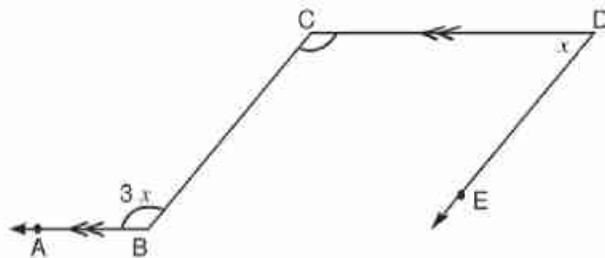

2 In this figure:

$\overline{AB} \parallel \overline{CD}$, and \overline{EF} is a transversal

[a] What angles are equal in measure to $\angle EXB$?

[b] What angles are equal in measure to $\angle XYC$?

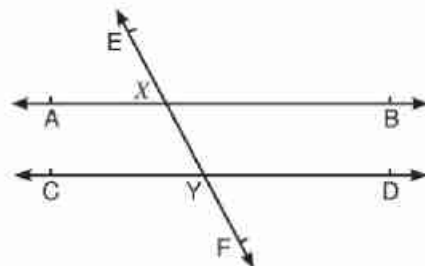

3 In this figure.

$\overrightarrow{BA} \parallel \overrightarrow{DE}$ calculate: $x + y + z$.

(Hint: Draw a line through C parallel to \overrightarrow{BA}).

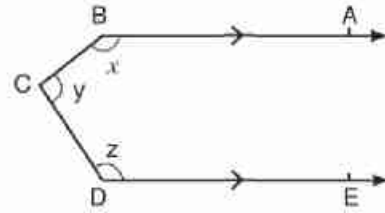

4 Find the value of x in each figure:

[a]

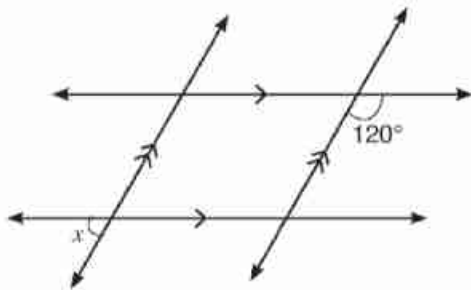

[d]

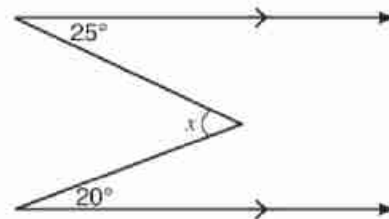

[b]

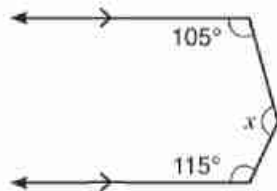

[e]

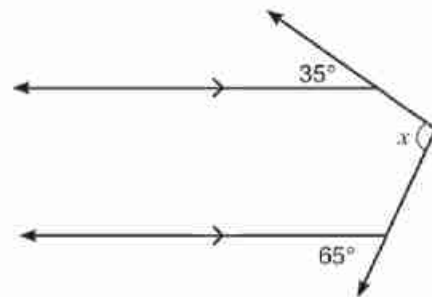

[c]

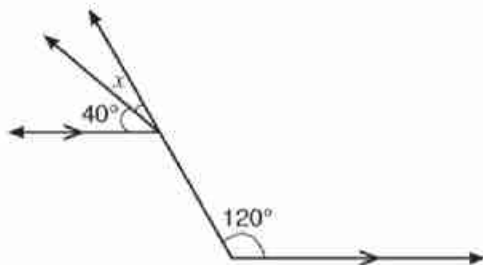

[f]

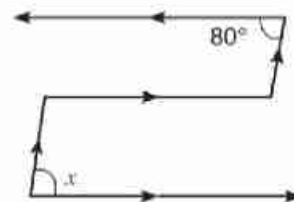

5 In this figure.

$$m(\angle AFG) = m(\angle B) = m(\angle K) = m(\angle M)$$

write the four pairs of parallel lines.

Give your reasons.

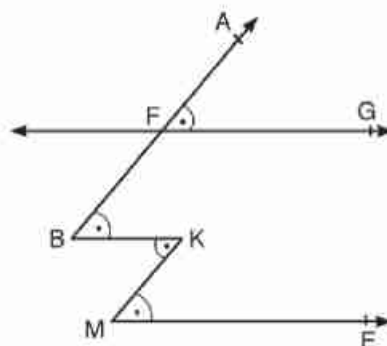

6 In the these figures:

Name the pairs of parallel lines in each Figure:

[a]

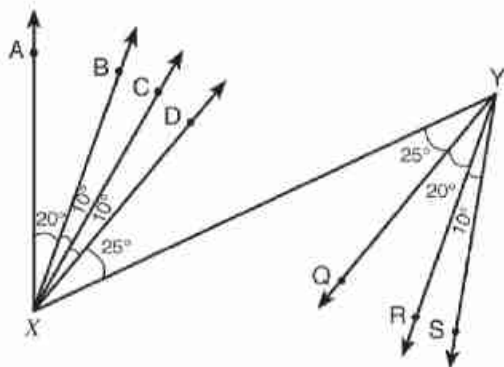

[b]

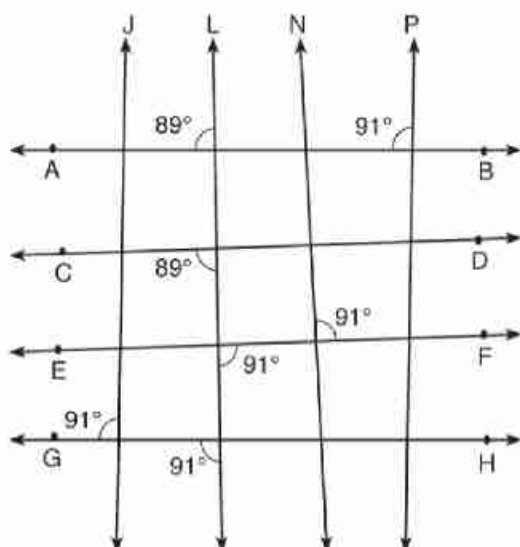

1 Constructing the bisector of a given angle

Given: $\angle ABC$ is a given angle

construction: The bisector of $\angle ABC$

Procedure:

- 1 With B as a centre and a suitable radius, draw an arc that intersects \overrightarrow{BA} at X and \overrightarrow{BC} at Y.
- 2 With each of X and Y as centre and a suitable radius, draw two arcs which intersect at Z.
- 3 Draw \overrightarrow{BZ}

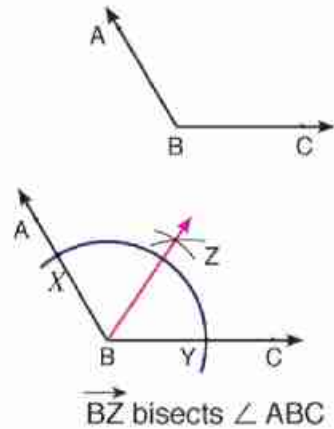

Complete:

\overrightarrow{BZ} is the of symmetry of $\angle ABC$.

2 Constructing a perpendicular from a point outside a straight line

Given: \overleftrightarrow{AB} is a given straight line, $P \notin \overleftrightarrow{AB}$

Construction: The perpendicular to \overleftrightarrow{AB} from P.

Procedure:

- 1 With P as a centre and a suitable radius, draw an arc which intersects \overleftrightarrow{AB} at points X and Y.
- 2 With each of X and Y as centres and a suitable radius, draw arcs which intersect at a point Z.
- 3 Draw \overleftrightarrow{PZ} .

Complete:

\overleftrightarrow{PZ} is the of symmetry of \overline{XY} .

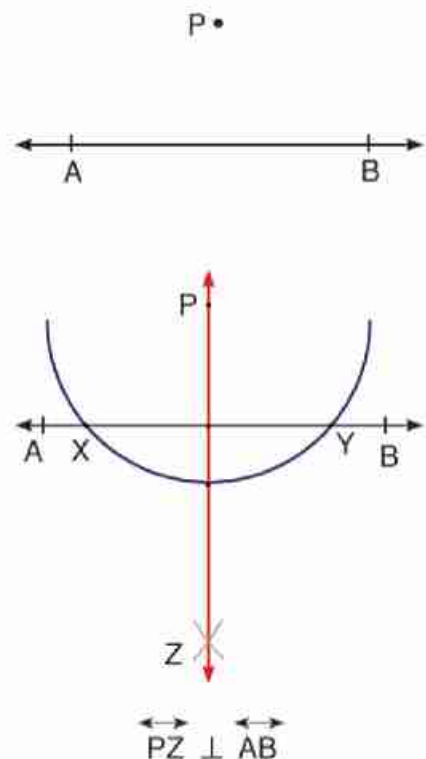

3 Constructing an angle to be congruent to a given angle:

Given: $\angle ABC$ is a given angle

construction: drawing $\angle DEF$ congruent to $\angle ABC$
"without using a protractor"

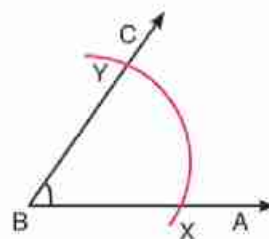

Procedure:

- 1 Draw a ray with start point E to represent one of the sides of the required angle.
- 2 Using the compasses, with B as a centre, and with suitable radius draw an arc to cut \overrightarrow{BA} and \overrightarrow{BC} at X and Y respectively and with E as a centre, and with the same radius, draw an arc to cut the ray at D.
- 3 With X as a centre and with radius equals XY, then with D as a centre and with the same radius above, draw an arc to cut the first arc at F.
- 4 Draw \overrightarrow{EF} , then $\angle DEF$ is congruent to $\angle \dots\dots\dots$

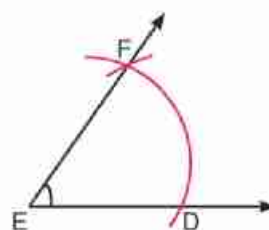
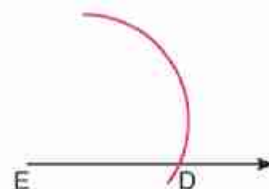

4 Activity : Bisecting a line segment

Given: \overline{AB} is defined line segment

Required: bisecting \overline{AB}

Steps:

- 1 Draw the line segment \overline{AB} .
- 2 Place the sharp point of a compass at point A, and adjust your compass to a length of \overline{AB} then draw 2 arcs at 2 different directions from \overline{AB} .
- 3 Place the sharp point of the compass at point B, and with the same length, draw 2 arcs at the different directions of \overline{AB} such that they intersect with the previous two arcs at points D, E.
- 4 Draw \overline{DE} to intersect \overline{AB} at C, then, the point C becomes the midpoint of \overline{AB} .

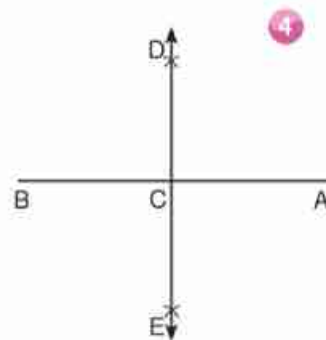
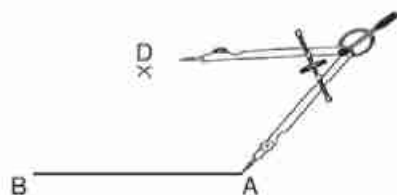

5 Drawing a perpendicular on a straight line that Passes by a point which belongs to that straight line.

Given: \overleftrightarrow{AB} is a defined straight line $C \in \overline{AB}$

Required: Drawing a Perpendicular line on \overleftrightarrow{AB} from point C

Steps:

1 Draw \overleftrightarrow{AB} and label \overline{AB}

2 Place the sharp point of a compass at C and adjust it to a suitable length then draw 2 arcs at 2 different directions from C Such that those arcs intersect \overleftrightarrow{AB} at the two points D and E.

3 Place the sharp point of a compass at both D and E and adjust it to a suitable length which is more than \overline{CD} , then draw two arcs that intersect at point M.

4 Draw \overline{MC} , then $\overleftrightarrow{MC} \perp \overleftrightarrow{AB}$

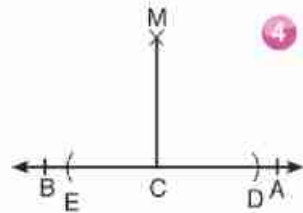
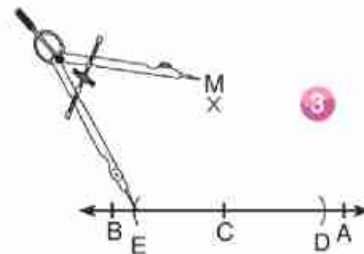
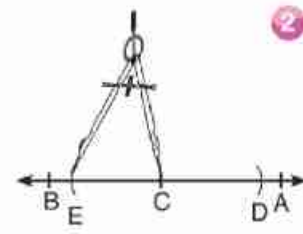
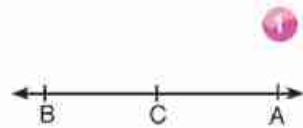

Drawing the scalene acute angled triangle ABC, and draw an axis of symmetry for each side “don’t erase the arcs” Do the axes of symmetry intersect in on point?.

Discuss:

- 1 If DEF is an obtuse angled triangle at E. Where do the axes of symmetry for its sides intersect?.
 - 2 If XYZ is a right angled triangle at Y. Where do the axes of symmetry for its sides intersect?.
 - 3 Measure the lengths of the line segments that connect the intersection point of the axes of symmetry with the vertices of the triangle in each case? What do you observe?.
- Two sharp point compass is used to measure the distance between two point.

6 Activity:

Drawing a straight line from a given point parallel to a given straight line.

Given: \overleftrightarrow{AB} is a given straight line, $C \notin \overleftrightarrow{AB}$

Required: Draw a straight line from point C parallel to \overleftrightarrow{AB}

Steps:

- 1 Draw \overleftrightarrow{AB} , $C \notin \overleftrightarrow{AB}$
- 2 Draw \overleftrightarrow{XY} crosses through the point C and intersects \overleftrightarrow{AB} at Y.
- 3 At point C draw the angle XCD corresponding to $\angle AYX$ such that $\angle XCD = \angle XYA$ as shown in the previous activity.

Then $\overleftrightarrow{CD} \parallel \overleftrightarrow{AB}$

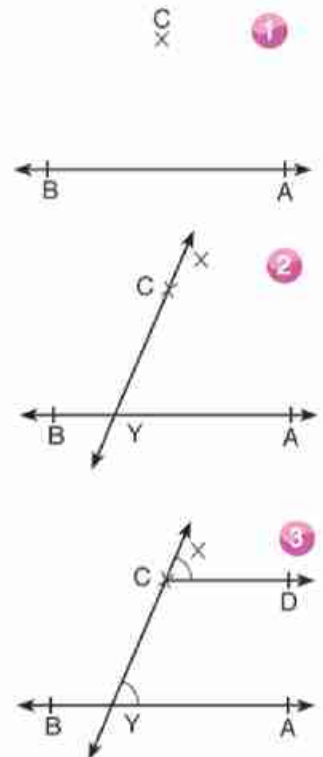

Exercise (4–5)

1 Do the indicated construction (Don't remove the arcs)

[a] The perpendicular to AB from P

[b] The bisector of $\angle ABC$

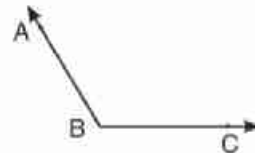
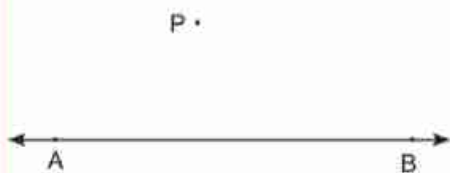

[c] The bisector of $\angle XYZ$

[d] The axis of symmetry of \overline{AB}

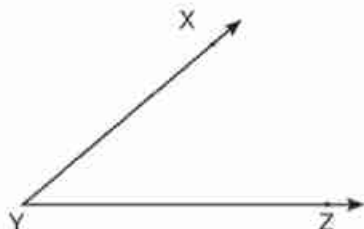

2 [a] Draw any acute angled triangle. Bisect each of the three angles.

[b] Draw any obtuse angled triangle. Bisect each of the three angles.

[c] What do you notice about the points of intersection of the bisectors in parts (a) and (b)?

3 [a] Draw any acute angle triangle. construct the perpendicular bisector of each side.

[b] Do the perpendicular bisectors intersect in one point?

[c] Repeat parts (a) and (b) using an obtuse angled triangle.

4 [a] Draw any acute angled triangle. Construct the three altitudes.

[b] Do the straight lines that contain the altitudes intersect in one point?

[c] Repeat parts (a) and (b) using an obtuse angled triangles.

5 Use the ruler and protractor to draw the traingle ABC in which $AB = 5$ cm, $BC = 6$ cm, and $CA = 7$ cm. $D \in \overrightarrow{CB}$

[a] draw $\angle DBE$ congruent to $\angle A$

[b] Complete: $m(\angle ABE) = m(\angle \dots)$

- 6** Draw \overline{BC} in a suitable length, using a compass and the unscaled ruler, bisect \overline{BC} at D and from D draw the \overline{DA} perpendicular to \overline{BC} , then draw \overline{AB} and \overline{AC} . Compare the lengths of \overline{AB} and \overline{AC} using the compass. What do you observe?
- 7** Draw the isosceles triangle ABC in which $AB = AC$ using the compass, bisect \overline{BC} at D. Draw \overline{AD} and prove that $\overline{AD} \perp \overline{BC}$.
- 8** Draw the right angled triangle XYZ at Y using compass and ruler only. Bisect \overline{XZ} at M. Draw \overline{YM} . Are $MX = MY = MZ$? Draw other right angled triangles and repeat the same construction. Are $MX = MY = MZ$?

UNIT TEST

Answer all the questions

1 Complete:

[a] Calculate the measure of the unknown angle in each of the following:

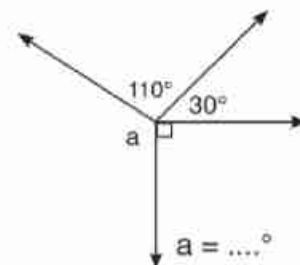
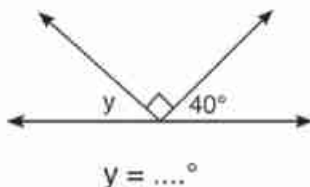
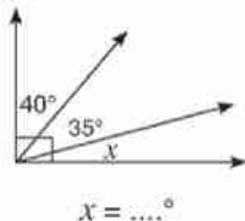

[b] For each of the following angles, write the closest measure from the following:
80°, 120°, 240°.

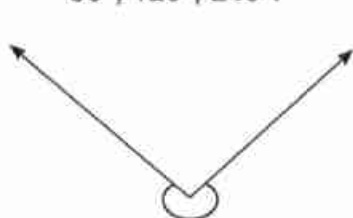

[c] Write the line segment which represents the hypotenuse in the triangle

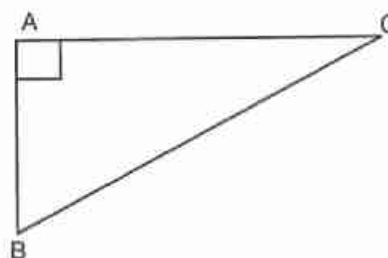

2 [a] Using a ruler and the compass, draw a triangle ABC in which $AB = AC = 7$ cm, $BC = 6$ cm. Bisect $\angle B$ and $\angle C$ by two bisectors which intersect at M. Is $MB = MC$?

[b] Using a ruler and a compasses, draw the triangle ABC in which $AB = AC = 5$ cm, $BC = 6$ cm, then draw $\overline{AD} \perp \overline{BC}$ Where $\overline{AD} \cap \overline{BC} = \{D\}$. Measure the length of \overline{AD} . (Don't remove the arcs).

3 Using the ruler and the compasses draw $\triangle ABC$ and bisect each of \overline{AB} , \overline{AC} at D,E respectively. Draw \overline{DE} .

[a] Using the compasses, measure \overline{DE} and satisfies that $BC = 2DE$.

[b] Is $\angle ABC = \angle ADE$? Does $\overline{DE} \parallel \overline{BC}$?

4 Draw $\triangle ABC$ in which $AB = 4$ cm, $BC = 5$ cm and $AC = 6$ cm. Construct the perpendicular bisectors of Triangle sides. What do you notice?

5 In the following figures, Find the two congruent triangles, give reasons, and write down the results of congruence:

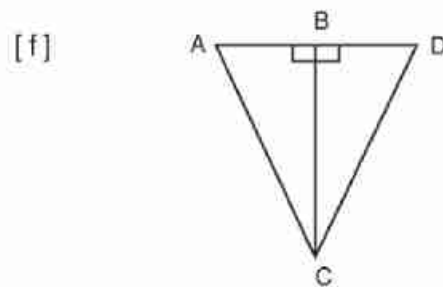
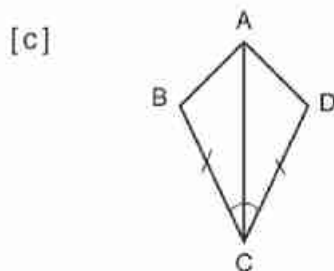
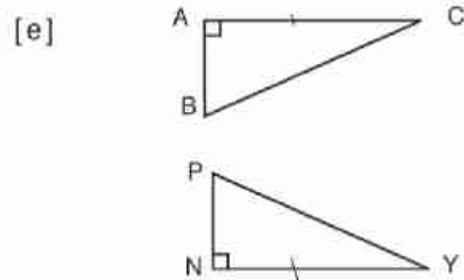
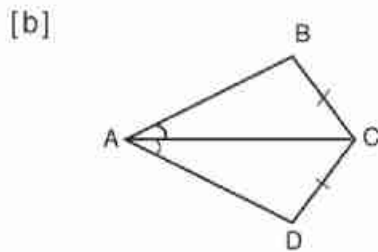
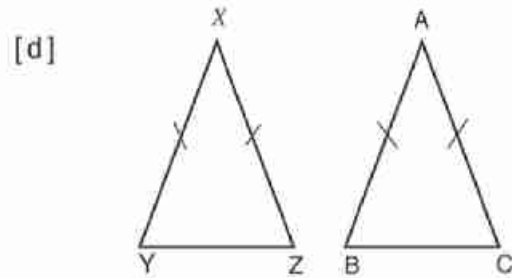
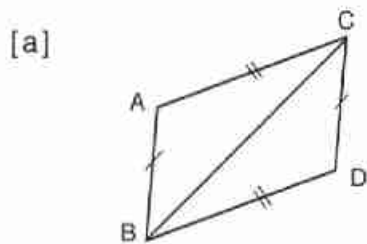

6 State which segments are parallel in each figure?

[a]

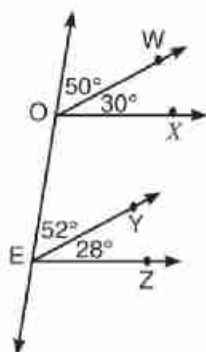

[b]

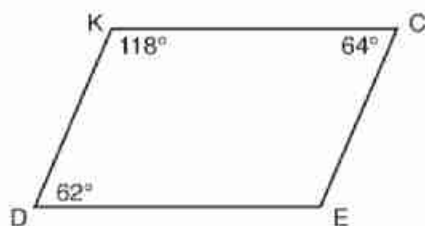

[c]

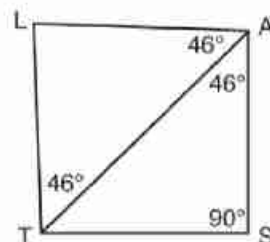

7 In the figure opposite:

$$m(\angle 1) = m(\angle 4),$$

$$\overleftrightarrow{BC} \parallel \overleftrightarrow{FD}$$

Does $\overleftrightarrow{BA} \parallel \overleftrightarrow{DE}$?

give reason

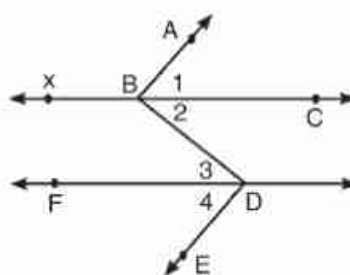

8 In the opposite figure:

$$\overleftrightarrow{AB} \parallel \overleftrightarrow{DC}, m(\angle EBC) =$$

$$53^\circ, m(\angle D) = 127^\circ$$

Is $\overleftrightarrow{BC} \parallel \overleftrightarrow{AD}$? state

the reason.

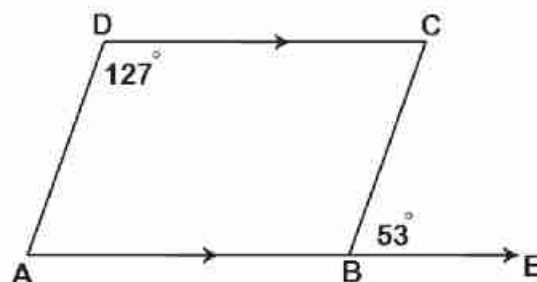

9 In the opposite figure:

$$\overleftrightarrow{AB} \parallel \overleftrightarrow{FE}, EF \cup AX = \{D\}$$

$$m(\angle DAB) = 69^\circ$$

$$m(\angle xDY) = m(\angle YDC)$$

$$= m(\angle CDE), \text{ find}$$

$$m(\angle CDE)$$

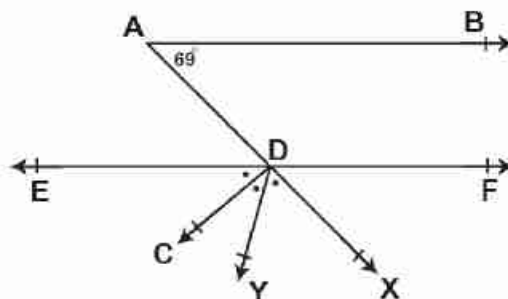

Model (1)

Answer the following questions:

Q1) Complete each of the following:

- 1) $2 \frac{1}{5} x \dots\dots\dots = 1$
- 2) If the order of the median of a set of values is the fourteenth, then the number of these values equals
- 3) $0.18 - 30\% = \dots\dots\dots$
- 4) $7 x^3 y^2 x \dots\dots\dots = 21 x^3 y^5$
- 5) $(2x - 3)(x + 5) = 2x^2 + \dots\dots\dots - 15$

Q2) Choose the correct answer from those given :

- 1) The rational number that lies on third of the way between 8 and 12 from the smaller is [$8 \frac{1}{3}$, 10 , $9 \frac{1}{3}$, $10 \frac{2}{3}$]
- 2) If the mode of the values 7 , 5 , $x + 4$, 5 , 7 is 5 then $x = \dots\dots\dots$ [1 , 4 , 5 , 7]
- 3) If $\Delta + \square = 20$, $\Delta + \Delta + \square = 35$ then $\Delta = \dots\dots\dots$ [15 , 20 , 5 , 10]
- 4) The arithmetic mean of the set of values 1 , 6 , 4 , 8 , 6 is [25 , 5 , 6 , 8]
- 5) If $\frac{2}{5} x = 10$, then $\frac{3}{5} x = \dots\dots\dots$ [25 , 15 , 20 , 5]
- 6) $0.7 + 0.\dot{3} = \dots\dots\dots$ [1 , 3.7 , $0.\dot{3}7$, $1 \frac{1}{30}$]

Q3) a) subtract:

- a) $5x^2 + y^2 - 3xy + 1$ from $6x^2 - 2xy + 3y^2$
- b) Use the distribution property find the value $\frac{27}{16} \times \frac{11}{7} + \frac{27}{16} \times \frac{11}{7} - \frac{27}{16} \times \frac{6}{7}$
(without using the calculator)

Q4) a) Simplify to the simplest form : $(2x - 3)(2x + 3) + 7$, and calculate the numerical value of the result when $x = -1$

b) Find three rational numbers that lie between $\frac{1}{2}$, $\frac{1}{3}$

Q5) a) Divide : $2x^3 + 3x^2 - 4x - 6$ by $2x + 3$

b) The following table shows Gehad's mark of mathematics in 6 months :

Month	October	November	December	February	March	April
Marks	30	35	42	37	44	50

Find the arithmetic mean of the marks.

Model (2)

Q1) Complete each of the following:

- 1) $24x^4y^8 = 6x^2y^3 \times \dots\dots\dots$
- 2) The remainder of subtracting $-3x$ from $2x$ is $\dots\dots\dots$
- 3) $1, 1, 2, 3, 5, 8, \dots\dots\dots$ (in the same pattern).
- 4) If the mode of the values $7, 5, a + 3, 5, 7$ is 7 , then $a = \dots\dots\dots$
- 5) $5x^2 + 15xy = 5x(\dots\dots\dots + \dots\dots\dots)$

Q2) Choose the correct answer from those given :

- 1) The algebraic term $6x^3y^2$ is of $\dots\dots\dots$ degree
 - a) third
 - b) fourth
 - c) fifth
 - d) sixth
- 2) The rational number that lies in half way between $\frac{1}{3}$ and $\frac{5}{9}$ is $\dots\dots\dots$
 - a) $\frac{2}{3}$
 - b) $\frac{3}{4}$
 - c) $\frac{4}{9}$
 - d) $\frac{5}{27}$
- 3) The multiplicative inverse of the member $\left(\frac{1}{2}\right)^{\text{zero}}$ is $\dots\dots\dots$
 - a) 2
 - b) -2
 - c) 1
 - d) -1
- 4) If $\frac{5}{x+2}$ is a rational number, then $x \neq \dots\dots\dots$
 - a) -2
 - b) zero
 - c) 2
 - d) 5
- 5) The median of the values $5, 4, 7$ is $\dots\dots\dots$
 - a) 4
 - b) 5
 - c) 7
 - d) 16
- 6) IF the arithmetic mean for the set of values $3, 5, x + 2$ is 4 ,
then the arithmetic mean for the two values $5 - X, 5 + 2X$ is $\dots\dots\dots$

(6 , 4 , 3 , 2)

Q3) a) Use the distribution property. Find the value of : $\frac{3}{7} \times 2 + \frac{3}{7} \times 6 - \frac{3}{7}$

b) Find three rational numbers that lie between $\frac{1}{2}$, $\frac{1}{3}$.

Q4) a) What is increase of $7x + 5y + z$ than $2x + 6y + z$.

b) Divide : $14x^2y - 35xy^2 + 7xy$ by $7xy$, $x \neq \text{zero}$, $y \neq \text{zero}$.

Q5) a) Simplify to simplest form : $(x - 3)(x + 3) + 9$ and calculate the numerical value of the result when $x = 5$.

b) If the arithmetic mean of the numbers 8 , 7 , 5 , 9 , 4 , 3 , $k + 4$ is 6, then find the value of k .

Model (3)

Merge Students

Q1) Complete each of the following:

- 1) The algebraic term $5x^2y$ is of degree.
- 2) $(x - 3)(\dots + \dots) = x^2 - 9$
- 3) The rational number which hasn't multiplicative inverse is
- 4) The median n of the set of values $3, 4, 5$ is
- 5) The number $\frac{4}{x}$ is a rational number if $x \neq \dots$

Q2) Choose the correct answer from those given:

- 1) If $\frac{4}{7}x = \frac{4}{7}$ then x [1, zero, 4, 7]
- 2) The arithmetic mean of the set of values $2, 3, 8, 2, 5 = \dots$ [3, 2, 4, 8]
- 3) The additive inverse of the number -3 is [-3, 3, $\frac{1}{3}$, $-\frac{1}{3}$]
- 4) The remainder of subtracting $7x$ from $9x = \dots$ [$2x$, $16x$, $-2x$, zero]
- 5) The mode of the values $3, 3, 4, 4, 5, 3$ is [4, 22, 5, 3]

Q3) a) Use the distribution property. Complete to find $\frac{5}{7} \times 8 + \frac{5}{7} \times 5 + \frac{5}{7}$

$$= \frac{5}{7} (\dots + \dots + \dots)$$

$$= \frac{5}{7} (\dots + \dots + \dots) = \dots$$

b) If $A = \frac{1}{2}$, $B = -2$ complete: $B \div A = (\dots) \div (\dots) = (\dots) \times (\dots) = \dots$

Q4) Put true (\checkmark) or false (x)

- 1) The quotient of $12x^4 + 6x$ by $6x$ is $2x^3 + 1$ ()
- 2) The H.C.F of $15x^5 + 5x$ is $5x^5$ ()

3) The rational number that lies between $\frac{1}{4}$ and $\frac{3}{4}$ is $\frac{1}{2}$ ()

4) $5x + 3x = 8x$ ()

5) $(x + 4)^2 = x^2 + k + 16$ then $k = 4x$ ()

Q5) Match from column (A) to column (B) :

(A)		(B)
1) If $\frac{x-7}{5} = \text{zero}$, then $x = \dots\dots\dots$	*	3
2) $3x^2 + 15y = \dots\dots (x^2 + 5y)$	*	7
3) $(3x + 5) + (4x - 5) = \dots\dots\dots$	*	50
4) $\frac{1}{2} = \dots\dots\dots \%$	*	1
5) If $\frac{A}{B} = \frac{1}{2}$, then $\frac{2A}{B} = \dots\dots\dots$	*	7x

Models of Examinations of geometry

Model (1)

Q1) Complete each of the following:

- The perpendicular bisector of a line segment is called
- In the opposite figure: if $\triangle ABC \cong \triangle XYZ$, $m(\angle A) + m(\angle B) = 140^\circ$, then $m(\angle Z) = \dots\dots\dots^\circ$



- If $m(\angle B) = 105^\circ$, then $m(\text{reflex } \angle B) = \dots\dots\dots^\circ$
- In the opposite figure : If $\overleftrightarrow{MB} \cap \overleftrightarrow{AC} = \{M\}$, $m(\angle AMB) = 60^\circ$, then the value of $x = \dots\dots\dots^\circ$.

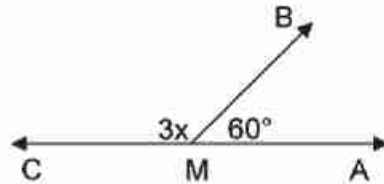

- The two right – angled triangles are congruent if,

Q2) Choose the correct answer from those given:

- If $\angle x \cong \angle y$, $\angle x$, $\angle y$ are supplementary angles, then $m(\angle x) = \dots\dots\dots^\circ$

[45 , 90 , 135 , 180]

- In the opposite figure : $\overleftrightarrow{AF} \parallel \overleftrightarrow{DE} \parallel \overleftrightarrow{CB}$, $AE = EC$ then $AD : AB = \dots\dots\dots : \dots\dots\dots$

[2:1 , 3:2 , 1:3 , 1:2]

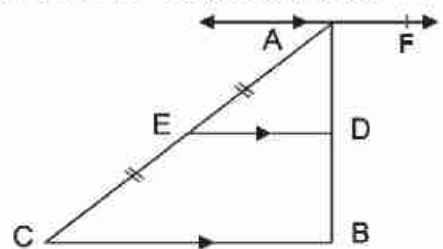

3) The two straight lines that are perpendicular to a third, then the two straight lines are
 [perpendicular, intersecting, congruent, parallel]

4) The measure of each of the two equal complementary angles equals°
 [180, 45, 360, 90]

5) If two straight lines intersect, then each two = angles have the same measure.
 [vertically opposite, adjacent, alternate, corresponding]

6) If $\triangle ABC \cong \triangle LMN$, then $m(\angle ACB) = m(\angle \dots)$
 [LMN, MLN, LNM, NLM]

Q3 a) In the opposite figure: $m(\angle BAD) = m(\angle BCD) = 90^\circ$, $AB = CB = 5\text{ cm}$, $AD = 3\text{ cm}$, mention the conditions for $\triangle ABD$, $\triangle CBD$ to be congruent and find the length of \overline{CD} ,

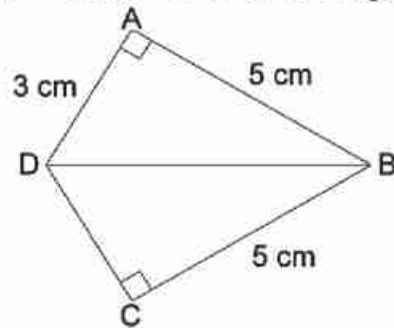

b) In the opposite figure: $\overline{AF} \parallel \overline{DE} \parallel \overline{XY} \parallel \overline{BC}$, $AD = DX = XB$, $AC = 9\text{ cm}$. Find the length of \overline{AY} , given the reason.

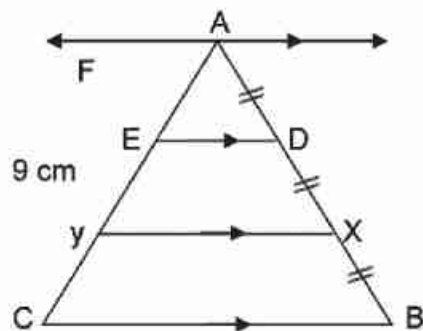

- Q4)** a) In the opposite figure: $\overline{AB} \parallel \overline{CD} \parallel \overline{EF}$, $m(\angle A) = 45^\circ$, $m(\angle E) = 130^\circ$,
find $m(\angle ACE)$

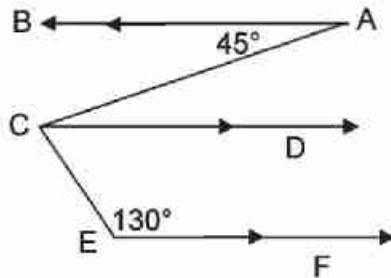

- b) In the opposite figure: $m(\angle AMB) = 110^\circ$, $m(\angle AMD) = 90^\circ$, $m(\angle DMC) = 40^\circ$. Find
with steps $m(\angle BMC)$.

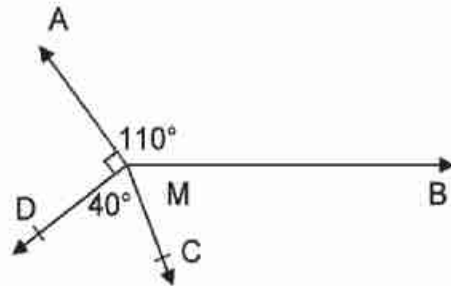

- Q5)** a) In the opposite figure: $\overline{AD} \cap \overline{BC} = \{M\}$, $BM = MC$, $AM = MD$, write the conditions
for $\triangle AMB \cong \triangle DMC$ to be congruent.

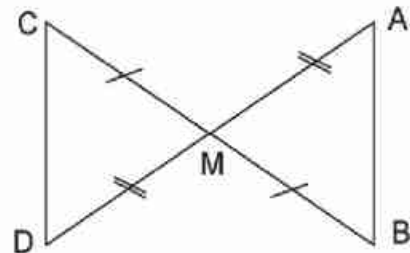

- b) By using your geometric instruments draw $\angle ABC$ whose measure 110° . Draw \overline{BF} to
bisect the angle.

Model (2)

Q1) Complete each of the following:

- 1) The sum of the measures of the accumulative angles at a point = $^{\circ}$
- 2) If a straight line intersects two parallel straight lines, then each two corresponding angles are
- 3) If $m(\angle A) = 110^{\circ}$, then $m(\text{reflex } \angle A) = \dots\dots\dots^{\circ}$.
- 4) The two right-angled triangles are congruent if
- 5) The two adjacent angles formed by intersecting a straight line and a ray are

Q2) Choose the correct answer from those given:

- 1) If $\angle x$ complements $\angle y$, $\angle x \cong \angle y$, then $m(\angle x) = \dots\dots\dots$ [45 $^{\circ}$, 90 $^{\circ}$, 180 $^{\circ}$, 360 $^{\circ}$]
- 2) The number of triangles in the opposite figure equals [4, 6, 7, 8]

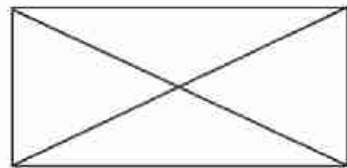

- 3) If the ratio between two supplementary angles is 5 : 13, then the measure of the smaller angles is [50 $^{\circ}$, 130 $^{\circ}$, 150 $^{\circ}$, 180 $^{\circ}$]
- 4) $\Delta ABC \cong \Delta XYZ$, $m(\angle A) + m(\angle B) = 100^{\circ}$, then $m(\angle Z) = \dots\dots\dots^{\circ}$
[50, 80, 90, 100]
- 5) The two straight lines that are perpendicular to a third, then the two straight lines are [perpendicular, parallel, congruent, intersecting]

6) The Figure number does not (1 , 2 , 3 , 4)

Congruent with the opposite figure

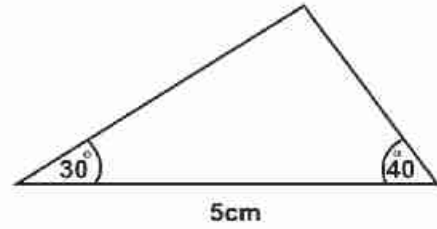

(1)

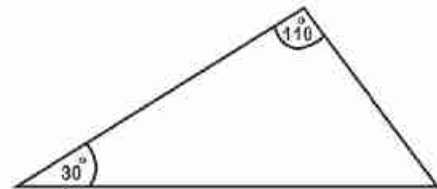

(2)

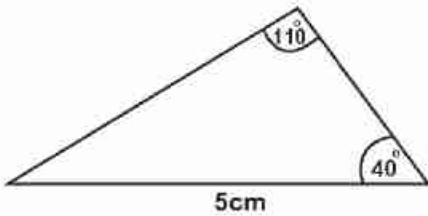

(3)

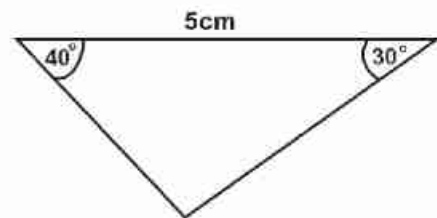

(4)

Q3) a) mention two cases of congruency of two triangles.

b) In the opposite figure $AB = BC$, $AD = CD$, $m(\angle C) = 80^\circ$, $m(\angle BDC) = 40^\circ$. Prove that $\triangle CBD \cong \triangle ABD$ and find $m(\angle ABD)$.

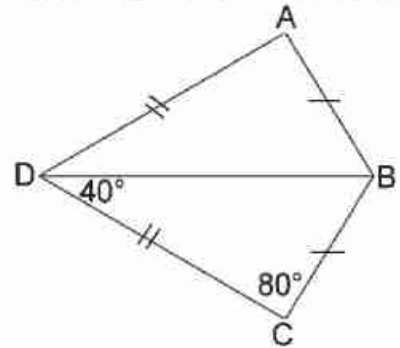

Q4) a) In the opposite figure $\overrightarrow{DE} \parallel \overrightarrow{AC}$, $m(\angle A) = 110^\circ$, $m(\angle D) = 70^\circ$ Find $m(\angle C)$. is $\overrightarrow{AB} \parallel \overrightarrow{CD}$? Given the reason.

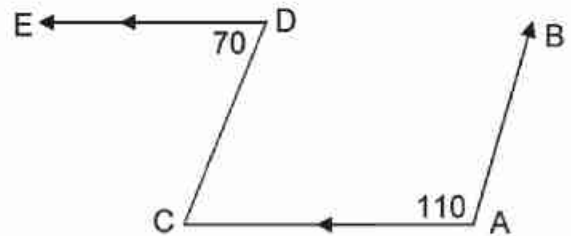

b) By using the ruler and the compasses draw the angle $\angle ABC$ where $m(\angle B) = 80^\circ$ and draw \overrightarrow{BD} to bisect the angle. Don't remove the arcs).

Q5) a) In the opposite figure $\overleftrightarrow{AC} \cap \overleftrightarrow{BD} = \{B\}$, $m(\angle ABD) = 50^\circ$, $m(\angle DBC) = 2x^\circ$, find in degrees the value of x .

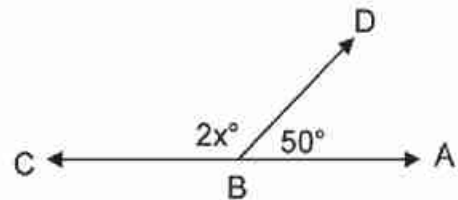

b) In the opposite figure \overrightarrow{BD} bisects $\angle ABC$, $m(\angle DBC) = 35^\circ$, $m(\angle BDC) = 120^\circ$. Find $m(\angle A)$ with degrees.

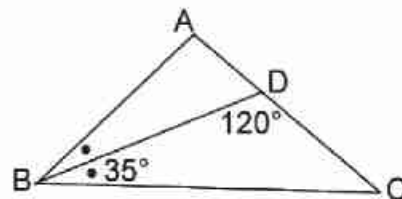

Model (3)

Merge Students

Q1) Complete each of the following:

- 1) If $m(\angle A) = 100^\circ$, then $m(\text{reflex } \angle A) = \dots\dots\dots^\circ$
- 2) The angle whose measure 50° complements an angle of measure $\dots\dots\dots^\circ$
- 3) The two straight lines parallel to a third are $\dots\dots\dots$
- 4) The two triangles are congruent if two sides and $\dots\dots\dots$ are congruent.
- 5) If $\triangle ABC \equiv \triangle XYZ$, then $m(\angle Z) = m(\angle \dots\dots\dots)$

Q2) Choose the correct answer from these given:

- 1) The sum of the measures of the accumulative angles at a point $\dots\dots\dots^\circ$
[630° , 180° , 90° , 360°]
- 2) The axis of symmetry of a line segments is $\dots\dots\dots$
[perpendicular form its midpoint, parallel to it, equal to it, congruent to it]
- 3) The supplement of the angle whose measure is $30^\circ = \dots\dots\dots$
[60° , 180° , 150° , 90°]
- 4) The angle whose measure is more than 90° and less than 180° is $\dots\dots\dots$ angle
[obtuse , acute , right , straight]
- 5) If $\triangle ABC \equiv \triangle XYZ$, then $AB = \dots\dots\dots$ [XY , XZ , YZ , BC]

Q3) Put (✓) for the correct statement and (X) for the in correct statement

- 1) The right - angled triangle congruent with the equilateral triangle ()
- 2) The two angles whose measures 100° , 80° are supplementary ()

3) In the opposite figure:

a) $\overleftrightarrow{AB} \parallel \overleftrightarrow{EF}$ ()

b) $X = 70^\circ$ ()

c) $y = 180^\circ$ ()

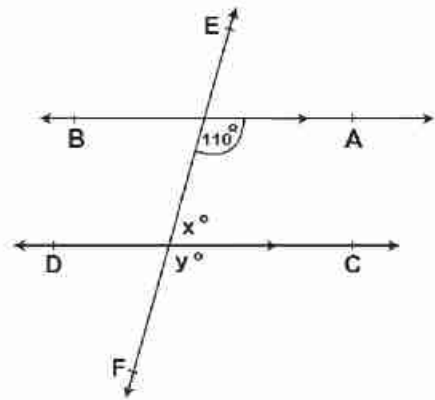

Q4) a) In the opposite figure:

$m(\angle ABC) = 50^\circ$, $\overline{BA} \parallel \overline{CD}$ complete to find : $m(\angle BCD)$

$\overline{BA} \parallel$

Then, $m(\angle ABC) = m(\angle \dots)$

, $m(\angle BCD) = \dots^\circ$

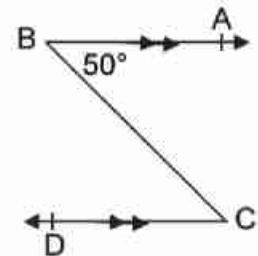

b) In the opposite figure complete:

1) $\triangle ABM \cong \triangle \dots$

2) $AB = \dots$ cm

3) $m(\angle B) = m(\angle \dots)$

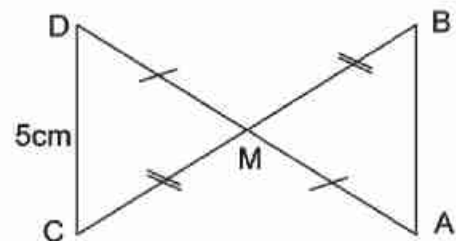

Q5) In the all figures opposite find the value of x:

1)

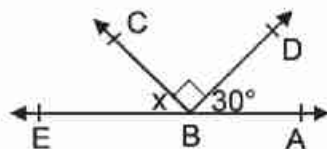

$x = \dots^\circ$

2)

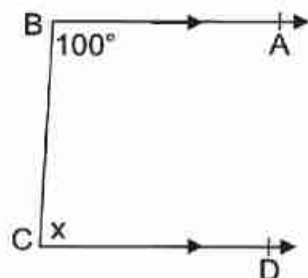

$x = \dots^\circ$

3)

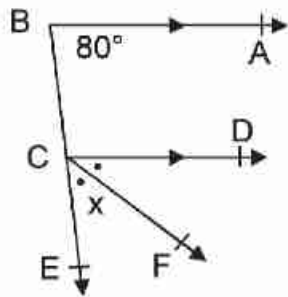

$x = \dots\dots\dots^\circ$

4)

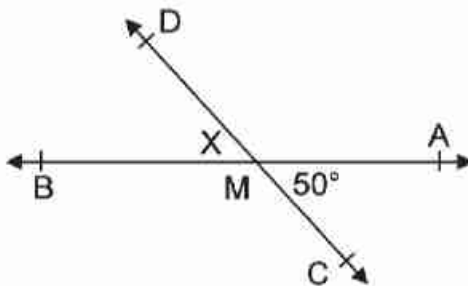

$x = \dots\dots\dots^\circ$

5) In the opposite figure :

If $\triangle ABC \cong \triangle DEA$

, $AE = 3\text{ cm}$, $DE = 4\text{ cm}$

, then $BE = \dots\dots\dots\text{cm}$

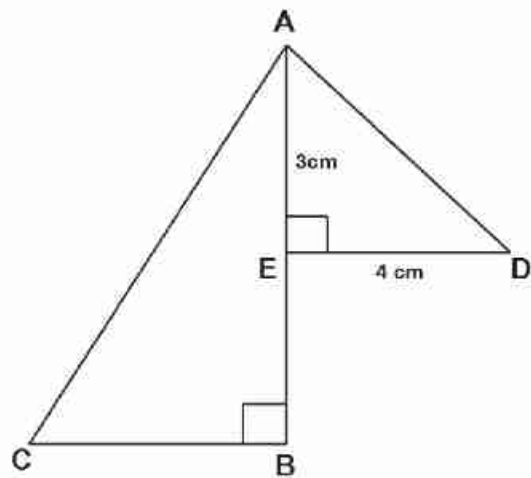

المواصفات الفنية:

الرياضيات ص ١ ع انجليزي فا ١

مقاس الكتاب:	$\frac{1}{8}$ (٨٢ × ٥٧) سم
طبوع المتن:	٤ ألوان
طبوع الغلاف:	٤ ألوان
ورق المتن:	٨٠ جم أبيض
ورق الغلاف:	٢٠٠ جم كوشيه
عدد الصفحات بالغلاف:	١٣٦ صفحة
رقم الكتاب:	١٥٢٧/١٠/١٥/١١/١/١٩
الكمية:	٣٥,٤٤٠ نسخة

<http://elearning.moe.gov.eg>

