



وزارة التربية والتعليم و التعليم الفني  
الإدارة المركزية للتعليم العام  
إدارة تنمية مادة الرياضيات

# برعاية معالي وزير التربية والتعليم و التعليم الفني السيد الأستاذ / محمد عبد اللطيف

ونوجيهات رئيس الإدارة المركزية للتعليم العام  
المشرف على مسنشارى المواد الدراسية

**د / هالة عبد السراج خفاجى**

إشراف علمي  
مسنشار الرياضيات

**أ / منال عزقول**

**إدعاءت و نقييمات لمنهج تطبيقات الرياضيات لفات**

للصف الثانى الثانوي " علمى "  
الفصل الدراسى الثانى  
للعام الدراسى 2025 / 2026

**الأسبوع التاسع**

إعداد

**أ / عفاف جاد**

**د / مدحت عطية شعراوى**

**أ / محمود سراج**

ترجمة

**أ / محمود سليمان نظيم**

مراجعة الترجمة

**أ / عمرو فاروق**

**أ / عثمان مصطفى عثمان**

(9) الأداء الصفّي - الصف الثاني الثانوي - علمي - تطبيقات الرياضيات لغات - الأسبوع التاسع (9)

- (1) The opposite figure shows a stationary body acting on a set of forces.  
Find the values of: F and K.

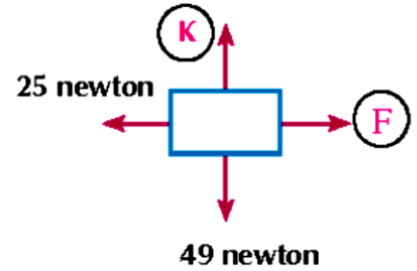

- (2) The opposite figure shows a body moving in the direction shown at a constant velocity under the action of a set of forces.  
Find the values of : F and K.

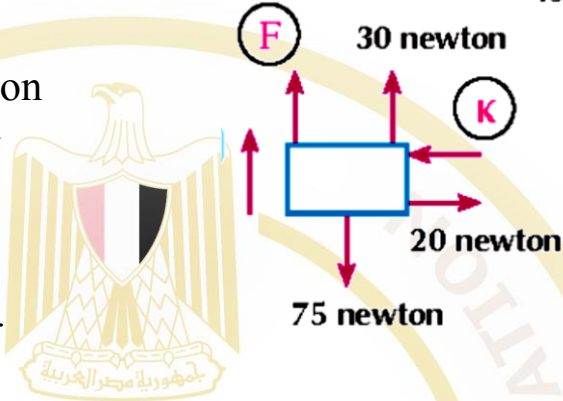

- (3) If an object moves at a constant velocity in a straight line under the action of the two forces:  $\vec{F}_1 = 4\vec{i} - m\vec{j}$ ,  $\vec{F}_2 = k\vec{i} + 7\vec{j}$ , find the value of :  $m + k$ .
- (4) A car with a mass of 6 tons is moving at a constant velocity under the action of a constant resistance of 4 kg.wt per ton of the car's mass. Find the force of the car's engine.
- (5) A train with a mass of 200 tons is moving at a constant speed. the force of the train's engine was 5 ton.wt Find the magnitude of the resistance per ton of the train's mass.
- (6) If a body of weight 24 kg.wt descends at a constant velocity on an inclined plane at an angle of  $60^\circ$  Find in kg.wt the resistance of the plane.
- (7) A parachutist and his equipment of weight 100 kg.wt , the air resistance to his movement is proportional to the square of his speed. If the maximum landing speed of the parachutist was 15 km/h, find the air resistance when his speed was 9 km/h.

- (8) A train with a mass of 180 tons moves under the action of a resistance proportional to the square of its speed. If this resistance was 10 kg.wt per ton of the train's mass when the train's speed was 72 km/h, find the maximum speed of the train if the locomotive is pulling it with a constant force of 5 ton.wt.
- (9) An object with a mass of 50 kg is placed on a horizontal plane and tied to a rope inclined to the horizontal at an angle of  $30^\circ$ . When the rope is pulled with a force of 20 kg.wt, the object moves at a constant speed on the plane. Find the resistance of the plane and the magnitude of the normal reaction of the plane.
- (10) An object with a mass of 60 kg is pulled at a constant speed on a horizontal plane by a rope inclined to the horizontal by an angle whose cosine is equal to 0.8, If the tension force of the rope is 40 kg . wt, find: the resistance of the plane and the magnitude of the normal reaction of the plane.

## (9) الأداء المنزلي - الصف الثاني الثانوي - علمى - تطبيقات الرياضيات لغات - الأسبوع التاسع (9)

(1) The opposite figure shows a stationary body acting on a set of forces.

Find the values of: F and K.

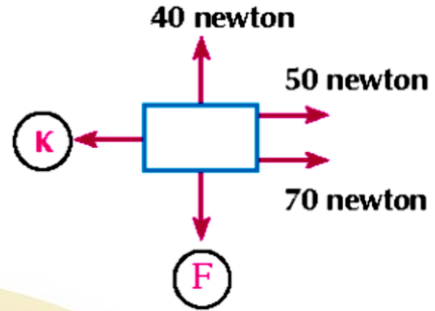

(2) The opposite figure shows a body moving in the direction shown at a constant velocity under the action of a set of forces.

Find the values of : F and K.

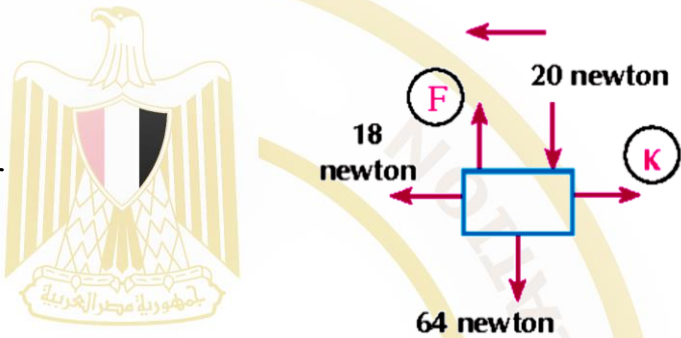

(3) If an object moves at a constant velocity in a straight line under the action of the two forces:  $\vec{F}_1 = 6\vec{i} - m\vec{j}$  ,  $\vec{F}_2 = k\vec{i} + 5\vec{j}$  , find the value of:  $m + k$

(4) A car with a mass of 5 tons is moving at a constant velocity under the action of a constant resistance of 3 kg.wt per ton of the car's mass. Find the force of the car's engine.

(5) A train with a mass of 80 tons is moving at a constant speed. the force of the train's engine was 4 ton.wt Find the magnitude of the resistance per ton of the train's mass.

(6) If a body of weight 20 kg.wt descends at a constant velocity on an inclined plane at an angle of  $30^\circ$  Find in kg. wt the resistance of the plane.

(7) A parachutist and his equipment of weight 90 kg.wt , the air resistance to his movement is proportional to the square of his speed. If the maximum landing speed of the parachutist was 12 km/h, find the air resistance when his speed was 8 km/h.

- (8) A train with a mass of 200 tons moves under the action of a resistance proportional to the square of its speed. If this resistance was 9.6 kg.wt per ton of the train's mass when the train's speed was 72 km/h, find the maximum speed of the train if the locomotive is pulling it with a constant force of 4.32 ton.wt
- (9) An object with a mass of 80 kg is placed on a horizontal plane and tied to a rope inclined to the horizontal at an angle of  $45^\circ$ . When the rope is pulled with a force of 48 kg.wt , the object moves at a constant speed on the plane . Find the resistance of the plane and the magnitude of the normal reaction of the plane.
- (10) An object with a mass of 70 kg is pulled at a constant speed on a horizontal plane by a rope inclined to the horizontal by an angle whose cosine is equal to 0.6. If the tension force of the rope is 35 kg . wt , find: the resistance of the plane and the magnitude of the normal reaction of the plane.

(9) التقييمات الأسبوعية - الصف الثانى الثانوى - علمى - تطبيقات الرياضيات لغات - الأسبوع التاسع (9)

**First Group**

(1) The opposite figure shows a body moving in the direction shown at a constant speed under the action of a set of forces.

Find the values of: F and M.

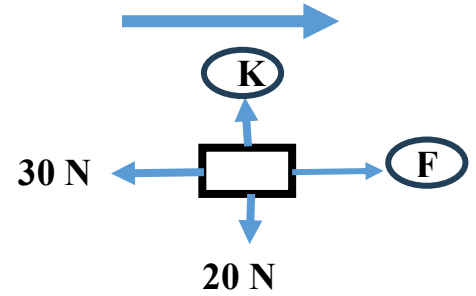

(2) If a body moves at a constant speed in a straight line under the action of the two forces:  $\vec{F}_1 = 3\vec{i} - m\vec{j}$ ,  $\vec{F}_2 = k\vec{i} + 4\vec{j}$  find the value of :  $m + k$ .

(3) A car with a mass of 6 tons moves at a constant speed under the action of a constant resistance of 5 kg.wt for each ton of the car's mass. Find the force of the car's engine.

(4) A body with a weight of 40 kg.wt falls at a constant speed on an inclined plane with an angle of sine of 0.6. Find in kg.wt the resistance of the plane.

(5) A parachutist and his equipment of weight 50 kg.wt, the air resistance to his movement is proportional to the square of his speed. If the maximum landing speed of the parachutist was 10 km/h, find the air resistance when his speed was 8 km/h.

### Second Group

(1) The opposite figure shows a body moving in the direction shown at a constant speed under the action of a set of forces. Find the values of: F and K.

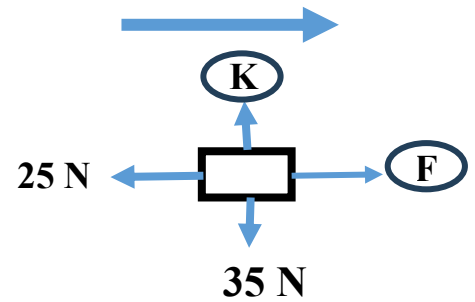

(2) If a body moves at a constant speed in a straight line under the action of the two forces:  $\vec{F}_1 = 5\vec{i} - m\vec{j}$ ,  $\vec{F}_2 = k\vec{i} + 4\vec{j}$ , find the value of:  $m + k$ .

(3) A car with a mass of 4 tons moves at a constant speed under the action of a constant resistance of 6 kg.wt for each ton of the car's mass. Find the force of the car's engine.

(4) A body of weight 25 kg.wt falls at a constant speed on an inclined plane with an angle of sine of 0.8. Find the resistance of the plane in kilograms weight.

(5) A paratrooper and his equipment weigh 80 kg.wt, and the air resistance to his movement is proportional to his speed. If the maximum landing speed of the paratrooper is 20 km/h, find the air resistance when his speed is 16 km/h.

### Third Group

- (1) The opposite figure shows a body moving in the direction shown at a uniform velocity under the action of a set of forces. Find the values of: F and k.

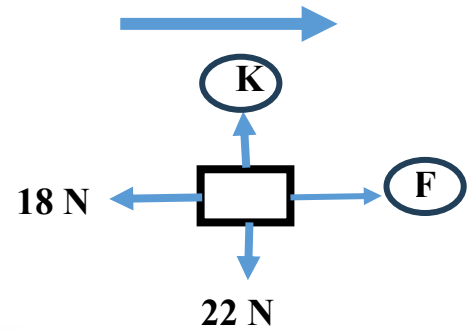

- (2) If a body moves at a constant velocity in a straight line under the action of the two forces:  $\vec{F}_1 = 9\vec{i} - m\vec{j}$ ,  $\vec{F}_2 = k\vec{i} + 6\vec{j}$ , find the value of:  $m + k$ .
- (3) A car with a mass of 7 tons moves at a constant velocity under the action of a constant resistance of 5 kg.wt for each ton of the car's mass. Find the force of the car's engine.
- (4) A body weighing 45 kg.wt falls at a constant velocity on an inclined plane with an angle of sine of 0.8. Find the resistance of the plane in kilograms weight.
- (5) A paratrooper and his equipment weigh 48 kg.wt, and the air resistance to his movement is proportional to his speed. If the maximum landing speed of the paratrooper is 16 km/h, find the air resistance when his speed was 10 km/h.